



# Filtration and Air Drying Products

Balston Product Catalog  
Bulletin FNS-H

aerospace  
climate control  
electromechanical  
**filtration**  
fluid & gas handling  
hydraulics  
pneumatics  
process control  
sealing & shielding



ENGINEERING YOUR SUCCESS.

# Parker Hannifin Corporation

## The Global Leader in Motion and Control Technologies

We engineer success of our customers around the world, drawing upon nine core motion and control technologies. These technologies enable virtually every machine and process to operate accurately, efficiently and dependably.

As the global leader in motion and control, we partner with our distributors to increase our customers' productivity and profitability by delivering an unmatched breadth of engineered components and value-added services.

We continue to grow with our customers by creating application-focused products and system solutions. A key to our global expansion has been to follow our customers and establish operations, sales and service wherever they are needed. No single competitor matches Parker's global presence.



Corporate Headquarters  
in Cleveland, Ohio.

## Parker's Motion and Control Technologies

Aerospace	Hydraulics
Climate Control	Pneumatics
Electromechanical	Process Control
<b>Filtration</b>	Sealing & Shielding
Fluid & Gas Handling	

### Legal Notifications



FAILURE OR IMPROPER SELECTION OR IMPROPER USE OF THE PRODUCTS AND/OR SYSTEMS DESCRIBED HEREIN OR RELATED ITEMS CAN CAUSE DEATH, PERSONAL INJURY AND PROPERTY DAMAGE.

This document and other information from Parker Hannifin Corporation, its subsidiaries and authorized distributors provide product and/or system options for further investigation by users having technical expertise. It is important that you analyze all aspects of your application and review the information concerning the product or system in the current product catalog. Due to the variety of operating conditions and applications for these products or systems, the user, through its own analysis and testing, is solely responsible for making the final selection of the products and systems and assuring that all performance, safety and warning requirements of the application are met.

The products described herein, including without limitation, product features, specifications, designs, availability and pricing, are subject to change by Parker Hannifin Corporation and its subsidiaries at any time without notice.

### Offer of Sale

The items described in this document are hereby offered for sale by Parker Hannifin Corporation, its subsidiaries or its authorized distributors. This offer and its acceptance are governed by the provisions stated in the "Offer of Sale".

© Copyright 1995, 2014, Parker Hannifin Corporation, All Rights Reserved.

# Table of Contents

Balston Complete Air and Gas Solutions

iv

<b>Compressed Air Filters</b>	<b>1-70</b>
International ISO Standards	2
Compressed Air and Gas Water Separators	3-4
Filter Installation Recommendations	5-6, 9-10
Filter Cartridge and Housing Selection	6
Flow Rates	7-8
1/4" and 1/2" Line Size Filters	11-12
3/4" to 2" Line Size Filters	13-14
3" to 10" Line Size Filters	15-19
High Pressure Compressed Air Filters	20
Stainless Steel Compressed Air Filters for Harsh Environments	21-25
Disposable Filter Silencers	26-27
Low Flow, Compact Compressed Air Filters	28-29
Filter Regulators	30-31
Mist Lubricators	32-33
Air Preparation Filters	34-62
Automatic Drains - High and Normal Capacity	63
Condensate Drain - Zero Air / Zero Energy Loss	64-66
Differential Pressure Indicator Kit	67
Miniature Disposable Filter Units	68-69
<b>Sample Filters</b>	<b>71-116</b>
Sample Filter Functions	72-75
Application Recommendations	76-77
Filter Cartridge and Housing Selection	78
Vapor Adsorption Cartridges	79
Stainless Steel Sintered Metal Filter	80-81
Filter Cartridge, Housing Selection/Chemical and Temperature Resistance Selection	82
Flow Rates for Liquid Filters	83
Flow Rates for Air and Gas Filters	84-85
Miniature Disposable Filter Units / Nylon and PVDF Construction	86-88
1/4" and 1/2" Stainless Steel In Line Filters	89
Sample Filter Cartridge and Housing Selection	90
Balston OEM Disposable Filter Solutions	91-93
High Flow Stainless Steel Filter Housings for Moderate to High Pressure Applications	94-95
High Pressure Filter Housings for High Purity, Low Flow Applications	96
Stainless Steel Filter Housings for Liquids with a High Solids content	97
Miniature Filter Housings Convenient T-Type Filters	98
Low Internal Volume Filter Housings 1/4" and 1/2" Port Size	99
High Internal Volume Filter Housings for Removing Large Volumes of Contaminants	100

# Table of Contents

1/4" to 3/4" Plastic Filter Housings	101-102
Filters for Vehicle Emission Analyzers	103
Filters for Diesel Engine Analyzers	104
Series 98 Membrane Filters - Hydrophobic Membrane Protection	105
Series 98 Membrane Filters 1/4" Line Size	106
Series A98 Coalescer Membrane Combination Filters	107
Series A98/11 Series Coalescer Membrane Combination Filter	108
Series A39/12 Coalescer Membrane Combination Filter	109-110
39 Series Membrane Filters	111-112
Fast Loop Filters	113-114
Horizontally Mounted Sample Filter	115

## Vacuum Pump Exhaust and Inlet Filters 117-142

Exhaust Filters for Hazardous/Corrosive Applications	118-119
Vacuum Pump Exhaust Filters for Non-Hazardous/Non-Corrosive Applications	120-121
Vacuum Pump Inlet Filters for Vacuum Service to $10^{-6}$ Torr	122-123
Vacuum Pump Inlet Filters for Vacuum Service to 2 Torr	124-125
Recommended Exhaust Filters for Vacuum Pumps	126-140
Pump to Filter Adaptors Straight Thread to NPT Thread	141
Pump to Filter Adaptors Flange to NPT Thread	142

## Balston Liquid Filters 143-152

Filter Cartridge and Housing Selection	144
Chemical and Solvent Compatibility	145
1/4" to 3/4" Line Size	146-147
1" Line Size	148
1/2" to 2" Line Size	149
Disposable Filter Units for Liquids	150-151
Water Filter	152

## Filters for Steam Sterilization Systems 153-158

Steam Filters for Sterilizers	154-155
Water Filters for Washer Sterilizers	156-157
EtO Filters	158

## Natural Gas Filters 159-168

2" Through 10" Line Size Filters	160
2" Through 4" Line Size	161
6" Through 10" Line Size	162
Flow Rates	163
Low Pressure Natural Gas Filters	164-167

# Table of Contents

<b>GS Series Membrane Filters</b>	<b>169-176</b>
0.01 Micron Membrane Filters	170-171
Disposable Filter Units	172
1/8" to 1/2" Line Size Stainless Steel or PTFE Filter Housings	173-174
1/2" Line Size High Pressure Membrane Filters	175
0.01 Micron Membrane Filters Flow Rates	176
<b>Filters and Dryers for the Food Industry</b>	<b>177-212</b>
Steam Filters	178-179
Stainless Steel Harsh Environment Filters for Food Processing & Packaging	180-184
Filter Cartridges and Housing Selection - SS Harsh Environment Filters	181
1/4" to 1" Line Size Stainless Steel Filters for Harsh Environment	182-183
Flow Rates for Stainless Steel Harsh Environment Filters	183
Specifications and ordering - Stainless Steel Harsh Environment Filters	184
2 Stage Compressed Air Filter Systems	185-187
CAMTU Compressed Air Microbial Test Unit	188-191
3 Stage Sterile Air Filter Systems	192-197
Sterile Air Filters	198
Filter Cartridge Housing and Selection - Sterile Air Filters	199
Sterile Air Filters - Flow Rates	200
1/4" to 2" Line Size Sterile Air Filters	201
3" to 10" Line Size Filters	202-203
3" to 10" Line Size Sterile Air Filters	204-205
1/4" to 1" Line Size Steam I Sterile Air Filters	206-207
2" to 10" Line Size Steam Sterilizable Sterile Air Filters	208-209
Cabinet Dryers for Washdown Areas	210-211
<b>Compressed Air Dryers</b>	<b>213-229</b>
Membrane Air Dryers	214-215
Specifications, Flows, Ordering Membrane Air Dryers -40°F Dewpoint	216-217
IT Series Membrane Air Dryers for +35°F Dewpoint	218-220
Membrane Air Dryers for Coordinate Measurement Machines	221-222
SMART Dryer™ 5000 Series Membrane Air Dryers	223-225
Cabinet Dryers	226-227
PSA Air Dryers	228-229
<b>Customer Support and Service Network for Balston Products</b>	<b>230</b>
<b>Index</b>	<b>231-244</b>

# Balston® Complete Air and Gas Solutions

## Compressor Room

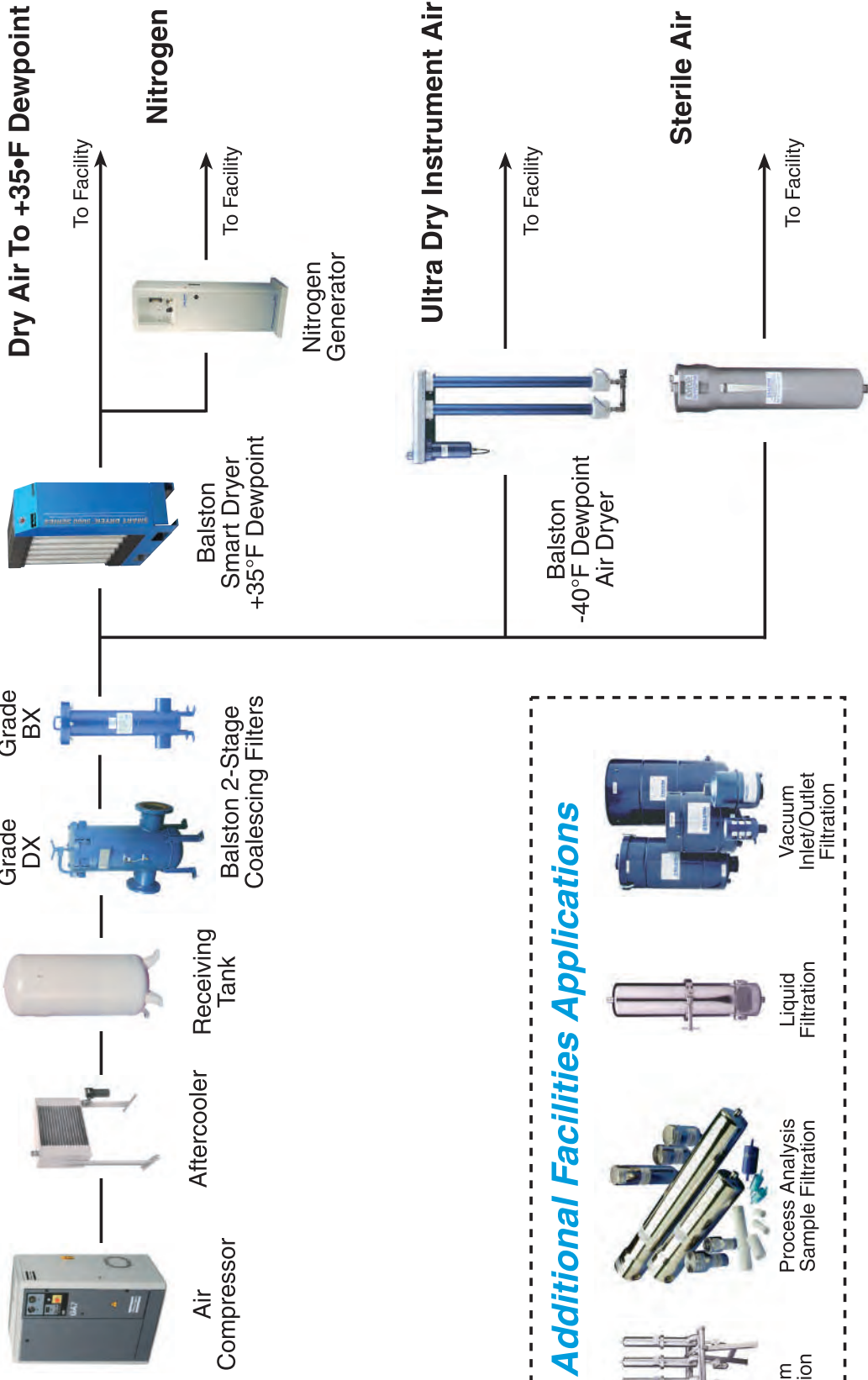

## Additional Facilities Applications



# Coalescing Compressed Air Filters

## Balston Microfiber® Filter Assemblies

Balston Coalescing Compressed Air Filters protect your equipment and delicate instruments from the dirt, water, and oil usually found in compressed air. Balston Coalescing Filters remove these contaminants at a very high efficiency up to 99.99% for 0.01 micron particles and droplets. Liquid releases from the filter cartridge to an automatic drain as rapidly as it enters the filter. This allows a Balston Coalescing Filter to continue removing liquids for an unlimited time without loss of efficiency or flow capacity. Select 1/4" to 2" line filters come with a lifetime (20 year) warranty which guarantees the product against defects and other failures.



## Product Features

- Remove 99.99% of 0.01 micron particles of oil, water, and dirt from compressed air and other gases
- Continuously trap and drain liquids
- Service flow ranges from a few SCFM to 40,000 SCFM
- Remove trace oil vapor with adsorbent cartridges
- Lifetime warranty (20 year) with select 1/4" to 2" line filters

Compressed Air Systems



Instrumentation and Automated Pneumatic Controls



Pneumatic Tools and Cylinders



# Compressed Air Filters

## International ISO Standards

Table taken from ISO8573 - 1

Compressed Air Filters

Class	Solid		Water		Oil	
	Maximum Particle Size (micron)	Maximum Concentration ppm (mg/m <sup>3</sup> )	Maximum Pressure Dewpoint °F (°C)	Maximum Pressure Dewpoint °F (°C)	Maximum Concentration ppm (mg/m <sup>3</sup> )	Maximum Concentration ppm (mg/m <sup>3</sup> )
1	0.1	.08 (0.1)	-94 (-70)	-94 (-70)	.008 (0.01)	.008 (0.01)
2	1	.8 (1)	-40 (-40)	-40 (-40)	.08 (0.1)	.08 (0.1)
3	5	4.2 (5)	-4 (-20)	-4 (-20)	.83 (1)	.83 (1)
4	15	6.7 (8)	37 (+3)	37 (+3)	4.2 (5)	4.2 (5)
5	40	8.3 (10)	45 (+7)	45 (+7)	21 (25)	21 (25)
6	-	-	50 (+10)	50 (+10)	-	-

ISO Class Example **1** Solid **4** Water **1** Oil

<p><b>ISO Class 2 2</b></p> <p>Any compressor with aftercooler and coalescer. Air intended for use with lubricated air tools, air motors, cylinders, shot blasting, non-frictional valves.</p> <p>ADDITIONAL SPECS: CGA - G7.1 (Grades A &amp; Ba1)</p>	<p><b>ISO Class 1 1</b></p> <p>Any compressor with aftercooler and 2-stage coalescing. Air intended for use as lubricated control valves, cylinders and parts blow-down.</p> <p>ADDITIONAL SPECS: Mil. Std. 282 H.E.P.A., U.S.P.H.S. 3A accepted particles for milk.</p>
<p><b>ISO Class 1 1</b></p> <p>Any compressor with aftercooler, 2-stage coalescing and activated carbon filter. Air intended for use with general pneumatics systems.</p> <p>ADDITIONAL SPECS: CGA - G7.1 (Grade C)</p>	<p><b>ISO Class 1 4 1</b></p> <p>Any compressor with aftercooler, 2-stage coalescing and refrigerated dryer for use with instrument quality air.</p> <p>ADDITIONAL SPECS: CGA - G7.1 (Grade D &amp; E) ISA S7.3, sFed. Std. 209 (Class 100)</p>
<p><b>ISO Class 2 2</b></p> <p>Any compressor with aftercooler, 2-stage coalescing, and a -40°F membrane air dryer. Air intended for use as industrial breathing air and decompression chambers.*</p> <p>ADDITIONAL SPECS: O.S.H.A. 29CFR 1910.134 *CO Monitor required.</p>	<p><b>ISO Class 1 1 1</b></p> <p>Any 2-stage compressor with aftercooler, double coalescing and a regenerative type desiccant dryer. Air intended for use in applications involving critical instrumentation and high purity gases.</p> <p>ADDITIONAL SPECS: CGA - G7.1 (Grade F)</p>

Note: In the pictorial examples shown above, the contribution of hydrocarbon vapors has not been taken into account in determining the OIL class category.



# Compressed Air Filters

## Compressed Air and Gas Water Separators

### Protect your equipment from contamination:

Balston's new water separators have been designed for the efficient removal of bulk liquid contamination from compressed air. Today, many products are offered for the removal of bulk liquid from compressed air, however, these are often selected based only upon their initial purchase cost, with little or no regard for the separation efficiency they provide or the cost of operation throughout their life. Balston's water separators have been designed from the ground up with the key design focus on air flow management, separation efficiency at all flow conditions, minimal pressure losses and independently validated performance.



### Separation Efficiency

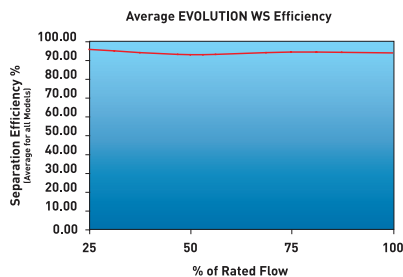

Tested with an Inlet challenge concentration of 33ml/m<sup>3</sup>hr and in accordance with ISO 8573.9. Performance shown is an average for all models in range. Individual model performance available on request.

### Product Features: Applications:

- Tested in accordance with ISO 8573.9
- High liquid removal efficiencies at all flow conditions
- Float drain automatically expels condensate build-up
- Low pressure losses for low operational costs
- Suitable for variable flow compressors
- Works with all types of compressor and compressor condensate
- Low maintenance
- Bulk liquid removal at any point in a compressed air system
- Protection to membrane and desiccant dryer prefiltration
- Liquid removal from compressor inter-coolers / after-coolers
- Liquid separation within refrigeration dryers

# Compressed Air Filters

## Compressed Air and Gas Water Separators

### Product Selection and Technical Data

Part Number	Port Size (inches) NPT	SCFM/Nm <sup>3</sup> /hr. at 100 psig (7 barg)	Max Operating Pressure psig (barg)	Max Operating Temp °F (°C)	Min Operating Temp °F (°C)
WS002N	1/4"	25 (42)	232 (16)	176 (80)	35 (1.7)
WS003N	3/8"	25 (42)	232 (16)	176 (80)	35 (1.7)
WS004N	1/2"	25 (4)	232 (16)	176 (80)	35 (1.7)
WSOH3N	3/8"	100 (170)	232 (16)	176 (80)	35 (1.7)
WSOH4N	1/2"	100 (170)	232 (16)	176 (80)	35 (1.7)
WS006N	3/4"	100 (170)	232 (16)	176 (80)	35 (1.7)
WS008N	1"	100 (170)	232 (16)	176 (80)	35 (1.7)
WSOH6N	3/4"	250 (425)	232 (16)	176 (80)	35 (1.7)
WSOH8N	1"	250 (425)	232 (16)	176 (80)	35 (1.7)
WS0010N	1-1/4"	250 (425)	232 (16)	176 (80)	35 (1.7)
WS0012N	1-1/2"	250 (425)	232 (16)	176 (80)	35 (1.7)
WSOH10N	1-1/4"	750 (1274)	232 (16)	176 (80)	35 (1.7)
WSOH12N	1-1/2"	750 (1274)	232 (16)	176 (80)	35 (1.7)
WS0016N	2"	750 (1274)	232 (16)	176 (80)	35 (1.7)
WS0020N	2-1/2"	1700 (2888)	232 (16)	176 (80)	35 (1.7)
WS0024N	3"	1700 (2888)	232 (16)	176 (80)	35 (1.7)

### Flow/Pressure

#### Correction Factors

(to calculate flow rates below and above 100 PSIG use this table)

Line Pressure psig (barg)	Correction Factor
15 (1)	0.25
29 (2)	0.38
44 (3)	0.50
58 (4)	0.63
73 (5)	0.75
87 (6)	0.88
100 (7)	1.00
116 (8)	1.06
131 (9)	1.12
145 (10)	1.17
160 (11)	1.22
174 (12)	1.27
189 (13)	1.32
203 (14)	1.37
218 (15)	1.41
232 (16)	1.46

### Dimensions and Weights

Part Number	Port Size (inches)	Dimensions inches (cm)			Weight lbs (kg)
		A	B	C	
WS002N	1/4"	3 (8)	7.2 (18)	6 (15)	1.3 (0.6)
WS003N	3/8"	3 (8)	7.2 (18)	6 (15)	1.3 (0.6)
WS004N	1/2"	3 (8)	7.2 (18)	6 (15)	1.3 (0.6)
WSOH3N	3/8"	3.8 (10)	9.3 (24)	7.9 (20)	2.4 (1.1)
WSOH4N	1/2"	3.8 (10)	9.3 (24)	7.9 (20)	2.4 (1.1)
WS006N	3/4"	3.8 (10)	9.3 (24)	7.9 (20)	2.4 (1.1)
WS008N	1"	3.8 (10)	9.3 (24)	7.9 (20)	2.4 (1.1)
WSOH6N	3/4"	5.1 (13)	10.8 (27)	9.2 (23)	4.8 (2.2)
WSOH8N	1"	5.1 (13)	10.8 (27)	9.2 (23)	4.8 (2.2)
WS0010N	1-1/4"	5.1 (13)	10.8 (27)	9.2 (23)	4.8 (2.2)
WS0012N	1-1/2"	5.1 (13)	10.8 (27)	9.2 (23)	4.8 (2.2)
WSOH10N	1-1/4"	6.7 (17)	17 (43)	15 (38)	11.2 (5.1)
WSOH12N	1-1/2"	6.7 (17)	17 (43)	15 (38)	11.2 (5.1)
WS0016N	2"	6.7 (17)	17 (43)	15 (38)	11.2 (5.1)
WS0020N	2-1/2"	8.1 (21)	19.9 (51)	17.5 (44)	22 (10.0)
WS0024N	3"	8.1 (21)	19.9 (51)	17.5 (44)	22 (10.0)

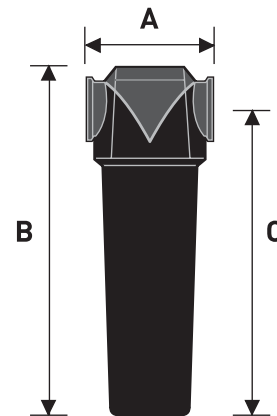

# Compressed Air Filters

## Filter Installation Recommendations

### Recommendations for Typical Filter Installations

Selecting the proper location for a filter in a compressed air line is as important as selecting the proper filter. In most cases you will probably be able to base your own installation on these recommendations for typical installations.

### Placing the Filter at the Compressor

The standard compressor installation consists of a prefilter (mounted on the compressor), a compressor, aftercooler, and a receiver. The Balston filter should be installed downstream from the receiver. In a system with an efficient aftercooler, the distance from the receiver to the filter is not important. Since the filter is usually maintained by the personnel responsible for the compressor, it is often convenient to install the filter downstream from the receiver. If there is no aftercooler, or the aftercooler is not efficient, coalescing filter be installed as close to the point(s) of use as possible.

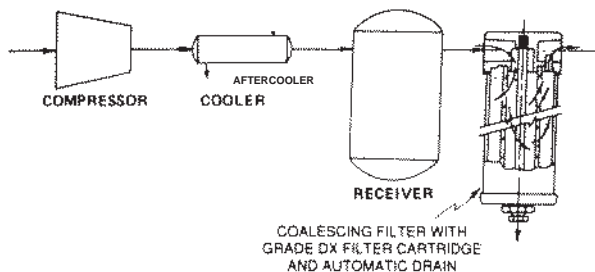

### Compressor Filter Specifications

Microfibre Filter Cartridge	Grade DX
Filter Housing	Determine filter size from flow chart on page 3, but port size must be equal to or larger than the line size
Automatic Drain	Recommended
Differential Pressure Indicator	Recommended

Some compressor installations do not have an aftercooler (this is an undesirable situation). Air saturated with water vapor leaves a compressor at 240°F to 400°F (116°C to 204°C). Without an aftercooler, the air cools close to room temperature in the distribution lines and water condenses throughout the air distribution system. About two-thirds of the total water content of the air

will be condensed when the air has cooled to 100°F (38°C). A filter located just before the main air line branches into smaller distribution lines will remove most of the water load from the system. The filter requirements for the main line are described above; they are the same as for a system with an aftercooler. However, since the air will continue to cool in the distribution system, additional filters located at end-use points will be required to remove water condensed downstream from the main line filter.

### How to Obtain a Trouble-Free Coalescer

The mechanism of coalescing leads to three important considerations in selecting and installing a coalescing filter:

- 1 The filter should be large enough to ensure that the air exits the filter at low velocity and does not carry over coalesced liquid. Proper sizing of a Balston coalescing filter is easily done by using the recommendations or the maximum flow rate data. There is no danger on oversizing the filter. A Balston coalescing filter is even more efficient at extremely low flow rates than at its maximum rated flow capacity.
- 2 To avoid liquid carryover, the coalesced liquid should not be allowed to build up in the filter housing above the level of the bottom of the filter tube. Rather than relying on operator attention to this easily-overlooked job, Parker Hannifin Corp. recommends automatic drains with all coalescing filters.
- 3 The flow direction through the Microfibre filter tube must be inside-to-outside to permit the liquid to drip from the outside of the tube to the drain in the filter housing. If installed outside-to-inside, the filter will at first function as a coalescing filter, but liquid will collect on the inside of the filter tube. Since there is no way of draining the liquid, the level will build up rapidly until it begins to be carried downstream by the air flow. The filter will work at removing liquids for a short time, and then not work at all. If the Balston coalescing filter exhibits these symptoms, reversing the flow direction will solve the problem.

# Compressed Air Filters

## Filter Cartridge and Housing Selection

### Filter Cartridge Description

General purpose applications such as plant compressed air	Single stage filtration. Use a Grade DX filter cartridge
Instrument air and other critical air requirements	Two stage filtration is necessary. Use a Grade DX followed by a Grade BX filter cartridge. As a general rule, a Grade BX filter cartridge should not be used alone.
Removal of trace compressor oil vapor	For rare instances where even a trace amount of oil vapor can cause a problem, three stage filtration is necessary. Use a Grade DX followed by a Grade BX, and a type CI cartridge.

### Physical Properties, Microfibre Filter Cartridges

Temperature Range	-150°F to 300°F (-100°C - 149°C)
Maximum Pressure Differential Across Filter, Inside-to-Outside Flow:	100 psi (7 bar)
Materials of Construction	Borosilicate glass microfibers with fluorocarbon resin binder. Resistant to water, all hydrocarbon and synthetic lubricants.

### Retention Efficiency

Grade	Efficiency for 0.01 Micron Particles and Droplets
DX	93%
BX	99.99%

### Balston Filter Cartridges

Balston provides two grades of coalescing filter cartridges, Grade DX and Grade BX. Singly or in tandem, these filters satisfy all requirements for removing liquid and solid contaminants from compressed air. Balston also has an activated carbon adsorbent CI-type cartridge for the removal of trace oil vapors from a compressed air line. The activated carbon cartridge is Grade 000.

### How to Select the Filter Cartridge and Housing

- 1 Decide which grade(s) of filter cartridges fits the application (see selection boxes at left).
- 2 Select the filter housing with a port size equal to the line size where the filter is to be located.
- 3 For a new installation in which the line size has yet to be selected, determine the gas flow rate and pressure at the point where the filter will be located, and then refer to the flow chart on the reverse side of this data sheet. NOTE: The filter port size must be equal to or larger than the line size (when specified).

### How to Order the Filter Assembly

- 1 Build your own custom filter assembly using the guideline matrix on Page 12 and specify your model number. Example: 1/2" filter with DPI and Auto Drain with Grade DX Filter = 6004N-01A-DX.
- 2 Each assembly is shipped with the filter cartridge installed. To order additional filter cartridges, indicate the model number of the cartridges, and the grade. Examples 050-05-DX, 050-05-BX. The grade used for Type CI cartridges is 000 (CI-100-12-000).

Note: Assemblies with CI Cartridges are shipped with the adsorbent cartridge wrapped separately. This shipping method prolongs the life of the cartridge.

# Compressed Air Filters

## Flow Rates

Filter Housing Model	Port Size	Filter Cartridge Grade	Flow rates SCFM, at 2 psi drop at indicated line pressure. Refer to Principal Specification for maximum pressure rating of each housing psig										
			2	20	40	80	100	125	150	200	250	400	650
A94A	1/4"	DX	4	9	13	24	29	36	43	55	67	—	—
A914, A914D, A914P		BX	1.2	2.4	4	7	8	9	12	15	17	—	—
2002	1/4"	DX	9	19	30	51	63	76	90	117	145	—	—
2003	3/8"	BX	3	8	11	21	25	31	36	47	58	—	—
2004	1/2"	CI	2	5	7	12	15	18	22	28	35	—	—
2104	1/2"	DX	19	41	65	113	137	166	196	257	316	—	—
		BX	9	19	30	51	63	76	90	117	145	—	—
		CI	6	12	19	32	39	48	56	73	90	—	—
2206	3/4"	DX	37	78	123	214	259	315	371	484	596	—	—
		BX	10	21	34	56	70	85	101	131	162	—	—
		CI	8	16	26	44	53	65	76	99	122	—	—
2208	1"	DX	55	115	181	314	380	463	546	711	877	—	—
		BX	11	23	37	64	77	94	111	144	178	—	—
		CI	10	20	32	56	67	82	96	125	154	—	—
2312	1 1/2"	DX	98	203	319	554	670	816	963	1254	1546	—	—
		BX	22	46	74	129	155	189	223	290	358	—	—
		CI	16	33	52	91	110	134	158	206	253	—	—
A15/80	2"	DX	160	333	525	908	1100	1340	1580	2060	2540	—	—
		BX	45	94	148	256	310	378	445	580	715	—	—
		CI	23	49	77	133	161	197	231	301	371	—	—
AKH-0280	3"	DX	364	760	1190	2060	2500	3045	3600	4680	5770	9030	14480
		BX	90	190	300	510	620	755	890	1160	1430	2240	3590
		CI	47	98	154	266	322	394	462	602	742	1160	1860
AKH-0480	4"	DX	740	1540	2430	4210	5100	6210	7300	9550	11750	18400	29480
		BX	180	380	590	1020	1240	1510	1780	2320	2860	4480	7180
		CI	94	196	308	632	644	780	920	1200	1480	2320	3710
AKH-0880	6"	DX	1500	3120	4910	8500	10300	12550	14800	19300	23700	37120	59460
		BX	360	750	1180	2050	2480	3020	3560	4640	5710	8940	14330
		CI	188	392	616	1064	1280	1560	1840	2390	2950	4620	7400
AKH-1480	8"	DX	2620	5450	8580	14860	18000	21900	25800	33700	41540	65050	104200
		BX	630	1310	2070	3580	4340	5300	6230	8120	10010	15680	25100
		CI	329	686	1078	1860	2250	2740	3230	4210	5190	8130	13020
AKH-2280	10"	DX	4080	8470	13350	23110	28000	34100	40200	52400	64590	101150	162050
		BX	1000	2070	3270	5660	6850	8340	9840	12800	15780	24700	39600
		CI	516	1077	1690	2920	3540	4310	5070	6610	8150	12760	20450

# Compressed Air Filters

## Flow Rates (metric)

Filter Housing Model	Port Size	Filter Cartridge Grade	Flow rates Nm <sup>3</sup> /hr, at 2 psi drop at indicated line pressure. Refer to Principal Specification for maximum pressure rating of each housing barg										
			0.14	1.4	2.8	5.5	6.9	8.6	10.3	13.8	17.3	27.6	44.8
A94A A914, A914D, A914P	1/4"	DX	7	15	22	241	49	61	73	93	114	—	
		BX	2	4	7	12	14	15	20	25	29	—	
2002	1/4"	DX	15	32	66	87	107	129	153	199	246	—	
2003	3/8"	BX	5	14	19	36	42	53	61	80	99	—	
2004	1/2"	CI	3	8	12	20	25	31	37	48	59	—	
2104	1/2"	DX	32	70	110	192	233	282	333	437	537	—	
		BX	15	32	51	87	107	129	153	199	246	—	
		CI	10	20	32	54	66	82	95	124	153	—	
2206	3/4"	DX	63	133	209	364	440	535	630	822	1013	—	
		BX	17	36	59	95	119	144	172	223	275	—	
		CI	14	27	44	75	90	110	129	168	207	—	
2208	1"	DX	93	195	308	533	646	787	928	1208	1490	—	
		BX	19	39	63	109	131	160	189	245	302	—	
		CI	17	34	54	95	114	139	163	212	262	—	
2312	1 1/2"	DX	167	345	542	941	1139	1386	1636	2131	2627	—	
		BX	37	78	126	219	263	321	379	493	608	—	
		CI	27	56	88	155	187	228	268	350	430	—	
A15/80	2"	DX	272	566	892	1543	1869	2277	2684	3500	4315	—	
		BX	76	160	251	435	527	642	756	985	1215	—	
		CI	39	83	131	226	274	335	392	511	630	—	
AKH-0280	3"	DX	618	1291	2022	3500	4248	5173	6116	7951	9803	15342	24602
		BX	153	323	510	866	1053	1283	1512	1971	2430	3806	6099
		CI	80	167	262	452	547	669	785	1023	1216	1971	3160
AKH-0480	4"	DX	1257	2616	4129	7153	8665	10551	12403	16225	19963	31262	50087
		BX	306	646	1002	1733	2107	2565	3024	3942	4859	7612	12199
		CI	160	333	523	1074	1094	1325	1563	2039	2515	3942	6303
AKH-0880	6"	DX	2549	5301	8342	14442	17500	21322	25145	32791	40266	63067	101023
		BX	612	1274	2005	3483	4214	5131	6048	7883	9701	15189	24347
		CI	319	666	1047	1808	2175	2650	3126	4061	5012	7849	12573
AKH-1480	8"	DX	4451	9260	14577	25247	30582	37208	43834	57256	70576	110520	177036
		BX	1070	2226	3517	6082	7374	9005	10585	13796	17007	26640	42645
		CI	559	1166	1832	3160	3823	4655	5488	7153	8818	13813	22121
AKH-2280	10"	DX	6932	14391	22682	39264	47572	57936	68300	89028	109738	171854	275323
		BX	1699	3517	5556	9616	11638	14170	16718	21747	26810	41965	67280
		CI	877	1830	2871	4961	6014	7323	8614	11230	13487	21679	34745

# Compressed Air Filters

## Filter Installation Recommendations

### Removing Oil from Compressed Air

The source of oil in compressed air is the compressor lubricant. The common plant problems resulting from oil in the air are caused by liquid oil depositing in valves, instrument control surfaces, and other critical points in the air distribution system.

Balston often receives inquiries from users of compressed air about removing oil vapor from the air, yet the only reason for concern about oil vapor in most applications is that it may condense to liquid oil. Just like water vapor, oil vapor will condense to liquid when the temperature is reduced or the air pressure is increased at constant temperature. However, the table below shows that while in theory, condensation of oil vapor and water vapor are similar, in practice the effect of condensation of the two vapors is quite different.

**Concentration of vapor, parts per million by weight (ppm) in air at 100 psig (7 barg), at indicated temperature**

	Petroleum Base Oil	Synthetic Oil	Water
80°F (27°C)	0.012	0.002	2,743.
100°F (38°C)	0.05	0.01	5,137.
125°F (52°C)	0.2	0.06	10,508.
150°F (66°C)	0.7	0.2	20,119.
200°F (93°C)	3.5	2.4	62,371.

From the above figures, one can calculate that if 100 SCFM (170Nm<sup>3</sup>/h) of air is filtered at 125°F (52°C) to remove all liquids, and is subsequently cooled to 80°F (27°C), condensed liquids would consist of: water 3.6 lbs. (1.64 kg) per hour, and either petroleum base oil 0.001 lbs. (0.46 g) per hour, or synthetic oil 0.0003 lbs. (1.4 g) per hour. Condensed water is potentially a serious problem, but the quantity of condensed oil vapor is extremely small.

Field tests show that the liquid oil in air from a well-maintained reciprocating compressor is typically in the range of 15 to 30 ppm. With an oil-sealed rotary screw compressor, liquid oil content in the compressed air can vary from 10 to more than 100 ppm, depending upon the efficiency of the bulk oil separator. Compared to these figures, the approximate 0.2 ppm of liquid oil which could result from oil vapor condensation is for practical purposes negligible.

Therefore, removing the liquid oil from compressed air with a Balston coalescing filter, even at temperatures as high as 125°F (52°C), will eliminate the chance of oil-caused problems downstream in virtually all installations.

There are rare instances in which even 0.2 ppm oil vapor in the air or gas can cause a problem; for example, in contact with a sensitive catalyst or other highly reactive material.

In those cases, the trace quantity of oil vapor can be reduced using an adsorbent-loaded cartridge, following coalescing filter to remove the liquid oil.

### Placing the Filter at the Point-Of-Use

Whether or not the system has an aftercooler, Balston strongly recommends a filter at each critical end-use point, even if a main line Grade DX filter has been used. The point-of-use filters will remove dirt and oil which may have been in the distribution lines, as well as water that has condensed downstream from the main filter. If there is a pressure regulator at the end-use point, the filter should be installed immediately upstream from the regulator. Alternatively, replace the existing regulator with a combination Balston filter-regulator.

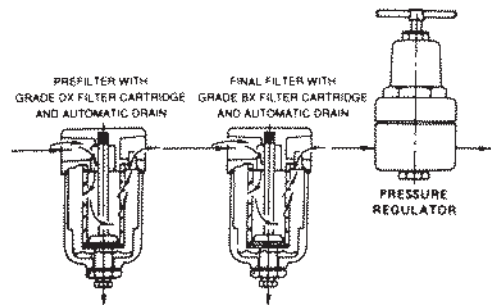

### Point-of-Use Filter Recommendations

Microfibre Filter Cartridge	Grade BX
Filter Housing	Size from flow chart or by line size
Automatic Drain	Recommended (refer to Page 18)

If there is no Grade DX filter upstream from the final filter, or if a significant amount of water or oil is expected, then a two-stage system, Grade DX followed by Grade BX, is required at each use point. The housing and automatic drain for the Grade DX prefilter should be the same as for the Grade BX final filter (if the flow capacities permit).

Even if the application is not particularly sensitive to impurities in the air - for example, an air-driven tool - it is still good practice to remove condensed water with a filter at the end of the line. Parker recommends a single-stage Grade DX filter with automatic drain.

# Compressed Air Filters

## Filter Installation Recommendations

### Using Filters With Air Dryers

Properly specified filters are relatively inexpensive protection for air dryers. Both refrigerated and desiccant dryers benefit from filter protection.

#### Refrigerated Dryers

A Grade DX prefilter with automatic drain should be installed upstream from a refrigerated dryer to prevent oil and condensed water from entering the dryer. Oil entering a dryer coats the cooling coil and reduces its efficiency; condensed water increases the cooling load and reduces dryer capacity. A dryer that was in operation before a Balston filter was installed may already have oil inside it. Therefore a second filter, a Grade BX filter with automatic drain, must be installed downstream from the dryer if oil-free air is required.

#### Desiccant Dryers

Desiccant dryers are very sensitive to water and oil droplets. Water can saturate the desiccant and reduce its drying efficiency or even destroy it. Oil can coat the desiccant, rendering it ineffective, or the oil can accumulate on the desiccant and create a combustion hazard when the desiccant is heated for regeneration.

For maximum protection of the desiccant dryer, a two-stage filter (Grade DX followed by Grade BX) system with automatic drains should be installed upstream from the dryer. To protect downstream delivery points from abrasive desiccant particles, a high efficiency filter with high solids holding capacity should be installed downstream from the dryer. The Balston Grade DX filter cartridge is recommended for this downstream installation location. (Note: All Balston desiccant dryers are equipped with prefilters and final filters, as recommended above).

#### Membrane Dryers

Membrane air dryers are sensitive to water and oil droplets. Oil can permanently damage the hollow fiber core. Balston Membrane Air Dryers are assembled with maximum protection, two stage coalescing filters (Grade DX followed by BX) designed to remove all contaminants down to 0.01 microns. Most all other membrane dryers are not assembled with adequate prefiltration protection and should be protected with a two stage Balston Filter System (Grade DX, Grade BX).

### Maintaining The Filters

In a typical compressed air delivery system, a properly specified Balston filter cartridge can be expected to last for one year. The filter cartridge can continue to coalesce indefinitely, but solids loading in the depth of the cartridge will cause a pressure drop through the housing. The filter should be changed when the pressure drop reaches 10 psi (0.7 barg). At pressure drops higher than 10 psig (0.7 barg), the cartridge will continue to perform at its rated efficiency, but downstream instrumentation may be affected by the pressure drop.

To monitor the condition of the filters, install Balston Differential Pressure Indicators (DPI) on the filters or across a multi-filter installation. The DPI gives a visual indication of differential pressure through the filter cartridge. The Balston Differential Pressure Indicator is factory-installed on 1/4" and larger line size Balston Compressed Air Filter Assemblies. To use a DPI with a smaller Balston Compressed Air Filter, pressure taps must be provided with "tees" on the line upstream and downstream from the filter.



# Compressed Air Filters

## 1/4" and 1/2" Line Size Filters

### Models A914D, A914P, A914, A914A

Models A914P and A914D are 1/4" line size assemblies with simple, reliable "automatic" drains used for low flow applications with moderate levels of liquid contaminate. The A914P is designed to empty condensate when there is a sudden pressure drop through the system (intermittent compressed air demand applications). The A914D incorporates an overnight drain which will drain liquid contaminate when the compressed air system pressure drops below 5 psig (0.4 barg). The standard A914 utilizes a standard manual threaded drain. All models have a transparent polycarbonate bowl with an aluminum head. The Model A914A has a zinc bowl.



Model A914D,  
A914P, A914



Model A914A

### Models 2002, 2003, and 2004

Models 2002 and 2003 are 1/4" and 3/8" line size assemblies. These filters have increased liquid holding capacity and are equipped with high capacity float drains, differential pressure indicators, sightglass, pressure relief valve, and 1/4 turn bayonet bowl closures. The 2004 series is designed to service 1/2" compressed air lines with low flow rates.

### Model 2104

The Model 2104 is a 1/2" line size assembly with an aluminum bowl. The filter housing has a large liquid holding capacity and a high capacity float drain, differential pressure indicator, sightglass, pressure relief valve, and 1/4 turn bayonet bowl closure.



Model 200X Series



Model 2104 Series

# Compressed Air Filters

## 1/4" and 1/2" Line Size Filters

### Principal Specifications

Model	A914	A914A	2002, 2003, 2004 (1)	2104 (1)
Port Size	1/4" NPT	1/4" NPT	1/4", 3/8", 1/2" NPT	1/2" NPT
Materials of Construction				
Head	Anod. Alum.	Anod. Alum.	Anod. Alum.	Anod. Alum.
Bowl	Polycarbonate	Zinc	Anod. Alum.	Anod. Alum.
Internals	Nylon	Nylon	Nylon	Nylon
Seals	Buna-N	Buna-N	Buna-N	Buna-N
Maximum Temperature	120°F (49°C)	220°F (104°C)	130°F (54°C) (2)	130°F (54°C) (2)
Maximum Pressure	150 psig (10.3 barg) (3)	250 psig (17.2 barg) (3)	250 psig (17.2 barg) (3)	250 psig (17.2 barg) (3)
Minimum Pressure	5 psig (0.4 barg) (4)	5 psig (0.4 barg) (4)	15 psig (1.03 barg) (4)	15 psig (1.03 barg) (4)
Shipping Weight	0.5 lbs. (0.2 kg)	0.5 lbs. (0.2 kg)	2.0 lbs. (0.9 kg)	2.5 lbs. (1.1 kg)
Dimensions	1.5"W X 4.0"L (4cm X 10cm)	1.5"W x 4.0"L (4cm X 10cm)	3.3"W X 8.5"L (8cm X 20cm)	3.3"W X 11.3"L (8cm X 28cm)

### Ordering Information

For assistance, call toll-free at 1-800-343-4048 8AM to 5PM Eastern Time

Model	A914	A914A (8)	2002, 2003, 2004 (1)	2104 (1)
Differential Pressure Indicator	Not Included (7)	Not Included (7)	Included (7)	Included (7)
Replacement Filter Cartridges				
No. Required	1	1	1	1
Box of 5	5/050-05-□ (5)	5/050-05-□ (5)	5/100-12-□ (5)	5/100-18-□ (5)
Cartridges Box of 10	050-05-□ (5)	050-05-□ (5)	100-12-□ (5)	100-18-□ (5)
CI Cartridge Box of 1	—	—	CI-100-12-000 (5)	CI-100-25-000 (5)

#### Notes:

- 1 Lifetime (20 year) Warranty included. Contact your local representative for details.
- 2 Automatic drain and Differential Pressure Indicator are temperature limiting factors. For Temperature capabilities to 220°F (104°C), order assemblies without automatic Drain and Differential Pressure Indicator.
- 3 Maximum pressure ratings are for temperatures to 130°F (54°C). Please consult factory for maximum pressure ratings at elevated temperatures.
- 4 Required for proper operation of piston drain, overnight drain, or float drain.
- 5 Indicate grade of filter cartridge by putting appropriate letter after ordering number. To order assembly with Type CI cartridges, add-000 after assembly number. Example: 2104N-0A0-000
- 6 Automatic drains not supplied with assemblies containing Type CI cartridges.
- 7 Differential Pressure Indicator (DPI) Kit may be ordered separately, P/N 41-071. DPI is sensitive in the range of 0-7 psi differential.
- 8 Order A914D- \_X for overnight drain installed in the filter assembly.  
Order A914P- \_X for piston drain installed in the filter assembly.  
Order A914A- \_X for aluminum bowl and 250 psig rating.

### How to Order the Filter Assembly\*

Build your own custom filter assembly using the guideline matrix below and specify your model number. Example: 1/2" filter with DPI and Auto Drain with Grade DX Filter = 2104N-1B1-DX.

\*Consult Factory. Not all configurations are available.

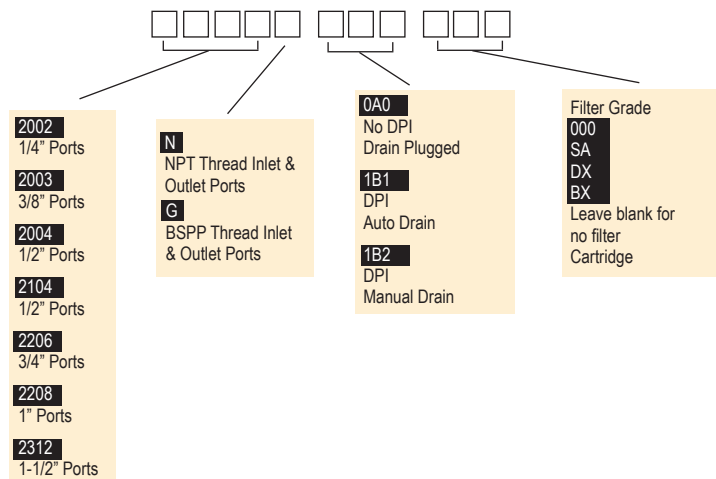

# Compressed Air Filters

## 3/4" to 2" Line Size Filters

### Models 2206, 2208, 2312, and A15/80

The Model A15/80 filter assembly has 2" NPT inlet and outlet ports, an automatic float drain and differential pressure indicator installed. The Models 2206, 2208, and 2312 filter assemblies have 3/4", 1", and 1 1/2" NPT inlet and outlet ports, respectively; these models are also equipped with automatic drains, sight glasses, pressure relief valve, bayonet closures, and differential pressure indicators. Materials of construction are shown below.



Model 2312N



Model 2206N



Model A15/80

### Principal Specifications

Model	2206 (1)	2208 (1)	2312 (1)	A15/80
Port Size	3/4" NPT	1" NPT	1 1/2" NPT	2" NPT
Materials of Construction				
Head	Anod. Alum.	Anod. Alum.	Anod. Alum.	Anod. Alum.
Bowl	Anod. Alum.	Anod. Alum.	Anod. Alum.	Steel
Internals	Aluminum	Aluminum	Aluminum	St. Steel
Seals	Buna-N	Buna-N	Buna-N	Buna-N
Maximum Temperature	130°F (54°C) (2)	130°F (54°C) (2)	130°F (54°C) (2)	130°F (54°C) (2)
Maximum Pressure	250 psig (17.2 barg) (3)	250 psig (17.2 barg) (3)	250 psig (17.2 barg) (3)	250 psig (17.2 barg) (3)
Minimum Pressure	15 psig (1 barg) (4)	15 psig (1 barg) (4)	15 psig (1 barg) (4)	15 psig (1 barg) (4)
Shipping Weight	8 lbs. (3.6 kg)	8 lbs. (3.6 kg)	15 lbs. (6.8 kg)	11 lbs. (5 kg)
Dimensions	4"W X 13"L (10cm X 33cm)	4"W X 13"L (10cm X 33cm)	5.0"W X 17"L (13cm X 43cm)	6.3"W X 28"L (16cm X 71cm)

#### Notes:

1 Lifetime (20 year) Warranty included. Contact your local representative for details.

2 Automatic Drain and Differential Pressure Indicator are limiting factors. For temperature capabilities to 220°F (104°C), order assemblies without Auto Drain and Differential Pressure Indicator.

3 Maximum pressure ratings are for temperatures to 130°F (54°C). Please consult factory for maximum pressure ratings at elevated temperatures.

4 Required for proper operation of the float drain.

5 Indicate grade of filter cartridge by putting appropriate letter after ordering number (please refer to PK1-2). Example: 5/150-19-DX, 200-35-BX.

6 The DPI is sensitive in the range of 0-5 psi differential.

### Ordering Information

For assistance, call toll-free at 1-800-343-4048 8AM to 5PM Eastern Time

Model	2206	2208	2312	A15/80
Differential Pressure Indicator	Included (6)	Included (6)	Included (6)	Included (6)
Replacement Filter Cartridges				
No. Required	1	1	1	1
Box of 5	5/150-19-□ (5)	5/150-19-□ (5)	5/200-35-□ (5)	5/200-80-□ (5)
Box of 10	150-19-□ (5)	150-19-□ (5)	200-35-□ (5)	200-80-□ (5)
CI Cartridge (Box of 1)	CI150-19-000	CI150-19-000	CI200-35-000	CI200-80-000

# Compressed Air Filters

Compressed Air Filters

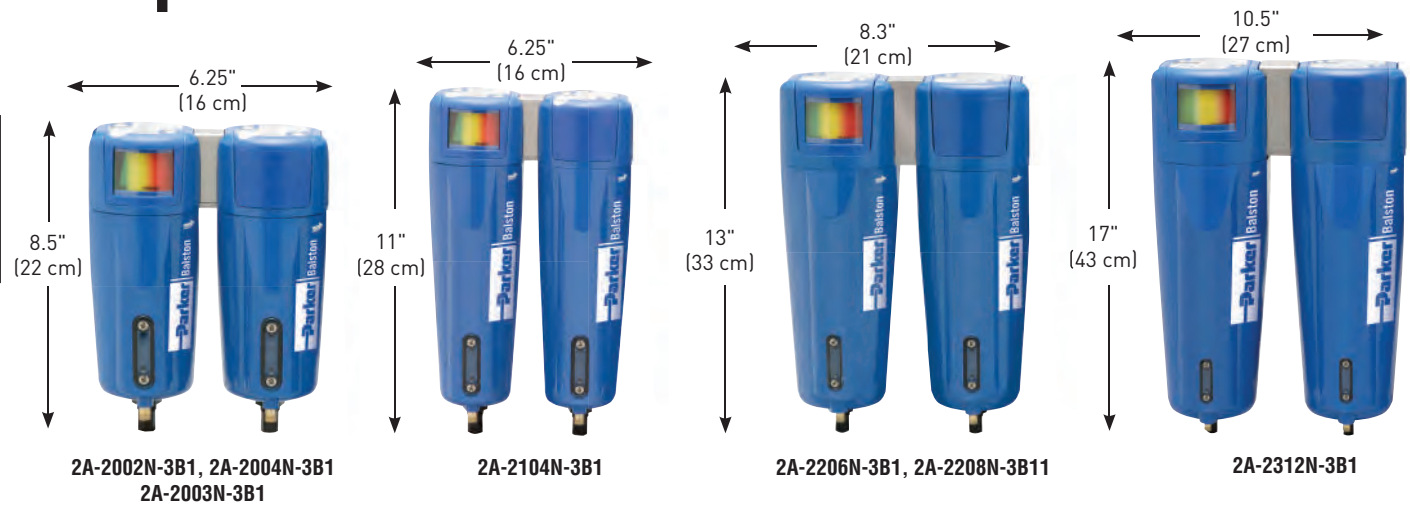

## Principal Specifications

Model	2A-2002, 2003, 2004	2A-2104	2A-2206	2A-2208	2A-2312
Port Size	1/4" NPT	1/2" NPT	3/4" NPT	1" NPT	1.5" NPT
Materials of Construction					
Head	Aluminum	Aluminum	Aluminum	Aluminum	Aluminum
Bowl	Aluminum	Aluminum	Aluminum	Aluminum	Aluminum
Internals	Aluminum	Aluminum	Aluminum	Aluminum	Aluminum
Seals	Buna-N Food Grade	Buna-N Food Grade	Buna-N Food Grade	Buna-N Food Grade	Buna-N Food Grade
Maximum Temperature (1)	130°F (54°C)	130°F (54°C)	130°F (54°C)	130°F (54°C)	130°F (54°C)
Maximum Pressure	250 psig (17.2 barg)	250 psig (17.2 barg)	250 psig (17.2 barg)	250 psig (17.2 barg)	250 psig (17.2 barg)
Minimum Pressure (2)	15 psig (1 barg)	15 psig (1 barg)	15 psig (1 barg)	15 psig (1 barg)	15 psig (1 barg)
Shipping Weight	4.2 lbs. (1.9 kg)	5 lbs. (2.3 kg)	11.7 lbs. (5.3 kg)	11.7 lbs. (5.3 kg)	27 lbs. (12 kg)
Dimensions	6.25"W X 8.5"L	6.25"W X 11"L	8.3"W X 13"L	8.3"W X 13"L	10.5"W X 17"L

### Notes:

1 Max. temperature with auto drain

2 Required for proper operation of auto drain.

## Ordering Information For assistance, call toll-free at 1-800-343-4048 8AM to 5PM Eastern Time

### Assembly Ordering Information

Model P/N		Replacement Cartridge	
		Box of 5	Box of 10
2A-2002N-3B1	1/4" 2-Stage (DX, BX) Filter Assembly	5/100-12-DX	100-12-DX
2A-2003N-3B1	3/8" 2-Stage (DX, BX) Filter Assembly	5/100-12-BX	100-12-BX
2A-2004N-3B1	1/2" 2-Stage (DX, BX) Filter Assembly		
2A-2104N-3B1	1/2" 2-Stage (DX, BX) Filter Assembly	5/100-18-DX 5/100-18-BX	100-18-DX 100-18-BX
2A-2206N-3B1	3/4" 2-Stage (DX, BX) Filter Assembly	5/150-19-DX 5/150-19-BX 5/150-19-SA	150-19-DX 150-19-BX
2A-2208N-3B1	1" 2-Stage (DX, BX) Stainless Assembly	5/150-19-DX 5/150-19-BX 5/150-19-SA	150-19-DX 150-19-BX
2A-2312N-3B1	1" 2-Stage (DX, BX) Stainless Assembly	5/200-35-DX 5/200-35-BX	200-35-DX 200-35-BX

4 2 each of mounting brackets are required for adequate support.

5 For CRN rated assemblies add a "C" to the Model Number. Example: 2A-C2104N-3B1

# Compressed Air Filters

## 3" to 10" Line Size Filters

### New LF/FF Series Multiple Cartridge Filter Assemblies

These filter assemblies provide high efficiency filtration of compressed air and other compressed gases at very high flow rates. With inlet and outlet ports accommodating 3" to 10" pipe sizes, the new LF/FF Series housings are capable of flow rates up to a maximum capacity of 37,350 SCFM (63,458 m<sup>3</sup>/h) at 100 psig (6.9 barg). The standard carbon steel units, which are generally in stock (through 6" line sizes), have pressure ratings up to 250 psig (17.2 barg).

All LF/FF series housings are ASME Code Stamped for the rated maximum operating pressure. All FF Series vessels have built-in legs for floor mounting. Selected models have swing bolt enclosures for easy access to the internals. The filter cartridges in all models are sealed by tightening the threaded retainer cap onto the rigid tie rod, ensuring a leak tight seal on both ends of the cartridge.

Each assembly is equipped with a carbon steel automatic float drain, differential pressure indicator, and a set of filter cartridges (except where noted).



Compressed Air Filters

#### Benefits

<i>Low Pressure Drop</i>	<i>Heat and Chemical Resistant</i>
<i>Lower Change out/Labor Costs</i>	<i>No Wet Zone</i>
<i>Lower Energy Costs</i>	<i>Oleophobic/Hydrophobic</i>
<i>High Dirt Holding Capacity</i>	<i>High Burst Strength</i>

#### Calculation with Part-Load Operation (100 hp compressor)

Annual Electricity Costs =  
 [(Motor full-load brake horsepower) x (0.746 kW/hp)  
 x (Annual Hours of Operation) x (Electricity Cost in \$/kWh)] x [(Percent of  
 time running fully loaded) + (0.30) x (Percent of time running unloaded)]  
 For example:  
 Full load motor efficiency = 90%  
 Motor full load bhp = 100 hp  
 Annual hours of operation = 8,760 hours (3-shift, continuous operation)  
 Runs 65% of the time fully loaded, 35% of the time unloaded  
 Unloaded operation consumes 30 percent of the electricity of fully loaded  
 operation  
 Cost of electricity = \$0.10/kWh  
**Annual electricity costs =**  
 [(100 hp) x (0.746 hp/kW) x (8,760 hrs) x \$0.10/kWh / 0.9] x [0.65 + (0.30) x  
 (0.35)] = **\$54,272.00**

# Compressed Air Filters

## 3" to 10" Line Size Filters

### HFC Savings

Annual electricity costs to operate a 100 HP Compressor can be as high as \$50,000. Pressure loss in the system adds to this expense. For a system operating at 100 psig (7 barg) that loses 2 psig (0.14 barg) of pressure through a filter, requires an additional 1% in operating energy costs (1).

Installing a single stage HFC Filter in place of a standard brand X filter, will reduce the pressure drop by 2+ psi (0.14 barg).

Based on a standard 100 HP (74.6 kW) compressor operating at a 65% load cycle, a 1% reduction in annual operating costs would be equal to \$542.00

**NEW!**

### High Flow Coalescing Filter Media HFC Grade

**Efficiency: 99.5% @ 0.5 micron**

Balston's HFC media consists of two layers. The outer layer features a dense matrix of glass fibers. It provides highly efficient coalescing aerosol removal and very low pressure drop. The inner layer, or initial stage of filtration, effectively traps dirt particles, protecting and extending the life of the outer layer. A metal retainer is used for strength and stability. This media is used in bulk coalescing applications and when relatively high efficiency and low pressure drop are required.



### High Efficiency Coalescing Media HEC Grade

**Efficiency: 99.97% @ 0.01 micron**

Air Flow: Inside to Outside

This coalescing element is composed of an epoxy saturated borosilicate glass micro-fiber tube. The HEC grade filter has a pleated cellulose inner layer as a built-in prefilter. This element is metal retained for added strength, and includes a synthetic fabric layer.

HEC filters are used when "total removal of liquid aerosols and suspended fines" is required. Because of its overall performance characteristics, this grade is most often recommended.

The HEC element is great prefilter protection for desiccant air dryers. This element prevents oil or varnish from coating the desiccant, while maintaining the dryer efficiency.



(1) Compressed Air Challenge, Doc # F9-1, April, 1998-Rev.0.

# Compressed Air Filters

**HFC MEDIA Max. Rated Flows (SCFM) at Various Operating Pressures  
(0.25 psi pressure drop)**

Model Number	2 psig	20 psig	40 psig	80 psig	100 psig	125psig	150 psig	175 psig	200 psig	220 psig	250 psig
ALN3-0128-HFC	363	753	1187	2056	2490	3033	3575	4118	4661	5095	5746
ALF3-0128-HFC	363	753	1187	2056	2490	3033	3575	4118	4661	5095	5746
ALF4-0125-HFC	483	1004	1583	2741	3320	4044	4767	5491	6215	6793	N/A
ALF6-0136-HFC	725	1507	2375	4112	4980	6065	7151	8236	9322	10190	N/A
ALF6-0328-HFC	1088	2260	3562	6167	7470	9098	10726	12354	13983	15285	N/A
AFN3-0128-HFC	363	753	1187	2056	2490	3033	3575	4118	4661	5095	5746
AFF3-0128-HFC	363	753	1187	2056	2490	3033	3575	4118	4661	5095	5746
AFF4-0125-HFC	483	1004	1583	2741	3320	4044	4767	5491	6215	6793	N/A
AFF6-0136-HFC	725	1507	2375	4112	4980	6065	7151	8236	9322	10190	11493
AFF6-0328-HFC	1088	2260	3562	6167	7470	9098	10726	12354	13983	15285	N/A
AFF8-0428-HFC	1450	3013	4750	8223	9960	12131	14302	16472	18644	20380	22984
AFF10-0728-HFC	2538	5273	8312	14391	17430	21229	25028	28826	32627	35665	40222
AFF12-1128-HFC	3988	8286	13062	22614	27390	33360	39330	45298	51271	56045	63206
AFF16-1528-HFC	5438	11299	17812	30837	37350	45491	53632	61770	69915	76425	86190

**HEC MEDIA Max. Rated Flows (SCFM) at Various Operating Pressures  
(1.5 psi pressure drop)**

Model Number	2 psig	20 psig	40 psig	80 psig	100 psig	125 psig	150 psig	175 psig	200 psig	220 psig	250 psig
ALN3-0128-HEC	218	454	715	1238	1500	1827	2154	2481	2808	3069	3462
ALF3-0128-HEC	218	454	715	1238	1500	1827	2154	2481	2808	3069	3462
ALF4-0125-HEC	219	605	954	1651	2000	2436	2872	3308	3744	4092	N/A
ALF6-0136-HEC	437	908	1431	2477	3000	3654	4308	4962	5616	6139	N/A
ALF6-0328-HEC	654	1362	2145	3714	4500	5481	6462	7443	8424	9207	N/A
AFN3-0128-HEC	218	454	715	1238	1500	1827	2154	2481	2808	3069	3462
AFF3-0128-HEC	218	454	715	1238	1500	1827	2154	2481	2808	3069	3462
AFF4-0125-HEC	291	605	954	1651	2000	2436	2872	3308	3744	4092	N/A
AFF6-0136-HEC	437	908	1431	2477	3000	3654	4308	4962	5616	6139	6923
AFF6-0328-HEC	654	1362	2145	3714	4500	5481	6462	7443	8424	9207	N/A
AFF8-0428-HEC	872	1816	2860	4952	6000	7308	8616	9924	11232	12276	13848
AFF10-0728-HEC	1526	3178	5005	8666	10500	12789	15078	17367	19656	21483	24234
AFF12-1128-HEC	2398	4994	7865	13618	16500	20097	23694	27291	30888	33759	38082
AFF16-1528-HEC	3270	6810	10725	18570	22500	27405	32310	37215	42120	46035	51930

# Compressed Air Filters

## HFC MEDIA Max. Rated Flows (Nm<sup>3</sup>/hr) at Various Operating Pressures (0.017 barg pressure drop)

Model Number	0.2 barg	1.4 barg	3 barg	4 barg	7barg	9 barg	10 barg	12 barg	14 barg	17 barg	20 barg
ALN3-0128-HFC	649	1291	2147	2681	4286	5355	5890	6960	8029	9634	11238
ALF3-0128-HFC	649	1291	2147	2681	4286	5355	5890	6960	8029	9634	11238
ALF4-0125-HFC	865	1721	2862	3575	5714	7141	7854	9280	10706	12846	N/A
ALF6-0136-HFC	1299	2582	4293	5363	8572	10711	11781	13920	16059	19268	N/A
ALF6-0336-HFC	1947	3873	6440	8044	12857	16066	17671	20879	24088	28901	N/A
AFN3-0128-HFC	649	1291	2147	2681	4286	5355	5890	6980	8029	9634	11238
AFF3-0128-HFC	649	1291	2147	2681	4286	5355	5890	6980	8029	9634	11238
AFF4-0125-HFC	865	1721	2862	3575	5714	7141	7854	9280	10706	12846	N/A
AFF6-0136-HFC	1233	2532	4265	5348	8597	10763	11846	14012	16178	19427	22676
AFF6-0328-HFC	1947	3873	6440	8044	12857	16066	17671	20879	24088	28901	N/A
AFF8-0428-HFC	2597	5164	8587	10726	17143	21422	23561	27839	32118	38535	44953
AFF10-0728-HFC	4519	9013	15005	18750	29984	37474	41219	48709	56199	67433	78668
AFF12-1128-HFC	7141	14200	23613	29496	47144	58909	64792	76557	88323	105971	123619
AFF16-1528-HFC	9738	19364	32199	40221	64287	80331	88353	104396	120440	144506	168572

## HEC MEDIA Max. Rated Flows (Nm<sup>3</sup>/hr) at Various Operating Pressures (0.10 barg pressure drop)

Model Number	0.2 barg	1.4 barg	3 barg	4 barg	7barg	9 barg	10 barg	12 barg	14 barg	17 barg	20 barg
ALN3-0128-HEC	391	777	1293	1615	2582	3227	3549	4194	4839	5805	6772
ALF3-0128-HEC	391	777	1293	1615	2582	3227	3549	4194	4839	5805	6772
ALF4-0125-HEC	481	1001	1695	2128	3429	4295	4729	5596	6463	7763	N/A
ALF6-0136-HEC	782	1556	2587	3232	5165	6454	7099	8388	9677	11611	N/A
ALF6-0328-HEC	1172	2332	3879	4846	7747	9681	10648	12581	14515	17416	N/A
AFN3-0128-HEC	391	777	1293	1615	2582	3227	3549	4194	4839	5805	6772
AFF3-0128-HEC	391	777	1293	1615	2582	3227	3549	4194	4839	5805	6772
AFF4-0125-HEC	481	1001	1695	2128	3429	4295	4729	5596	6463	7763	N/A
AFF6-0136-HEC	782	1556	2587	3232	5165	6454	7099	8388	9677	11611	13544
AFF6-0328-HEC	1172	2332	3879	4846	7747	9681	10648	12581	14515	17416	N/A
AFF8-0428-HEC	1563	3110	5172	6462	10329	12908	14197	16775	19354	23221	27089
AFF10-0728-HEC	2735	5442	9052	11308	18076	22588	24844	29357	33869	40637	47405
AFF12-1128-HEC	4297	8552	14224	17770	28406	35497	39042	46133	53224	63860	74496
AFF16-1528-HEC	3449	6864	11416	14262	22798	28489	31335	37026	42717	51253	59790

## Housing Selection Chart

Model Number	HFC Replacement Element	HEC Replacement Element	Port Size	Port Type	# of Elements
<b>LINE MOUNT VESSELS</b>					
ALN3-0128-H?C	510-28- HFC	510-28-HEC	3	NPT	1
ALF3-0128-H?C	510-28- HFC	510-28- HEC	3	FLANGE	1
ALF4-0125-H?C	850-25- HFC	850-25- HEC	4	FLANGE	1
ALF6-0136-H?C	850-36- HFC	850-36- HEC	6	FLANGE	1
ALF6-0328-H?C	510-28- HFC	510-28- HEC	6	FLANGE	3
<b>FLOOR MOUNT VESSELS</b>					
AFN3-0128-H?C	510-28- HFC	510-28- HEC	3	NPT	1
AFF3-0128-H?C	510-28- HFC	510-28- HEC	3	FLANGE	1
AFF4-0125-H?C	850-25- HFC	850-25- HEC	4	FLANGE	1
AFF6-0136-H?C	850-36- HFC	850-36- HEC	6	FLANGE	1
AFF6-0328-H?C	510-28- HFC	510-28- HEC	6	FLANGE	3
AFF8-0428-H?C	510-28- HFC	510-28- HEC	8	FLANGE	4
AFF10-0728-H?C	510-28- HFC	510-28- HEC	10	FLANGE	7
AFF12-1128-H?C	510-28- HFC	510-28- HEC	12	FLANGE	11
AFF16-1528-H?C	510-28- HFC	510-28- HEC	16	FLANGE	15



# Compressed Air Filters

## Drawings, Dimensions & Specifications

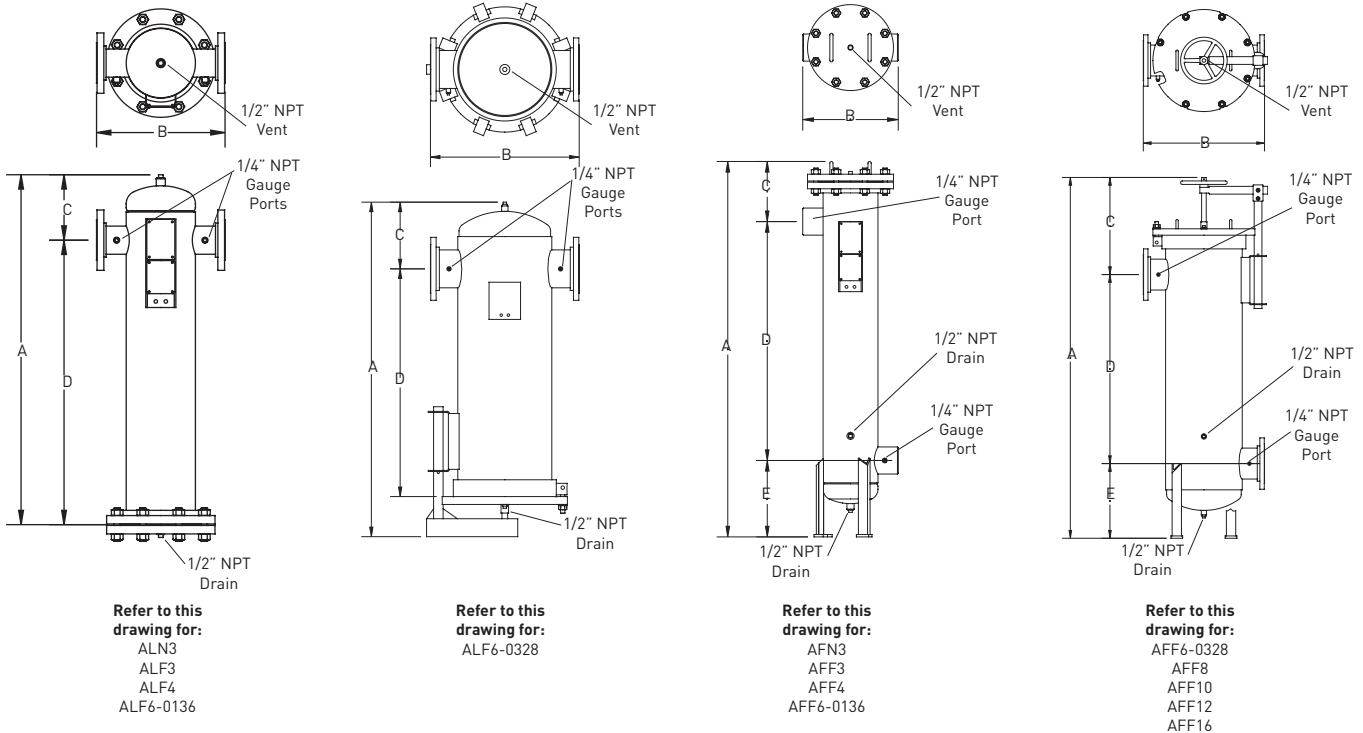

Dimensions	A	B	C	D	E	Element Removal Clearance Inches (centimeters)	Sump Capacity gallons (liters)	Weight pounds (kilograms)
ALN3	43.1 (109.5)	15.0 (38.1)	7.7 (19.5)	35.4 (89.9)	—	28 (71.1)	0.81 (3)	190 (86)
ALF3	43.1 (109.5)	16.0 (40.6)	7.7 (19.5)	35.4 (89.9)	—	28 (71.1)	0.81 (3)	190 (86)
ALF4	42.7 (108.5)	20.0 (50.8)	9.7 (24.6)	33.0 (83.8)	—	25 (63.5)	2.0 (7)	380 (173)
ALF6-0136	56.4 (143.3)	20.0 (50.8)	11.4 (29.0)	45.0 (114.3)	—	36 (91.4)	2.0 (7)	380 (173)
ALF6-0328	57.8 (146.8)	26.0 (66.0)	11.0 (27.9)	39.8 (101.1)	—	28 (71.1)	2.0 (7)	340 (155)
AFN3	58.9 (149.6)	15.0 (38.1)	9.4 (23.8)	37.5 (95.2)	12.0 (30.4)	28 (71.1)	1.1 (4)	190 (86)
AFF3	58.9 (149.6)	16.0 (40.6)	9.4 (23.8)	37.5 (95.2)	12.0 (30.4)	28 (71.1)	1.2 (4)	200 (91)
AFF4	63.3 (160.7)	20.0 (50.8)	12.3 (31.2)	35.0 (88.9)	16.0 (40.6)	25 (63.5)	4.2 (16)	370 (168)
AFF6-0136	75.3 (191.2)	20.0 (50.8)	12.3 (31.2)	47.0 (119.3)	16.0 (40.6)	36 (91.4)	3.6 (14)	410 (186)
AFF6-0328	77.3 (196.3)	26.0 (66.0)	20.8 (52.8)	40.5 (102.8)	16.0 (40.6)	28 (71.1)	5.0 (19)	340 (155)
AFF8	87.3 (221.7)	30.0 (76.2)	25.8 (65.5)	42.5 (108.0)	19.0 (48.3)	28 (71.1)	8.7 (33)	550 (250)
AFF10	96.0 (243.8)	34.0 (86.3)	28.5 (72.4)	45.5 (115.5)	22.0 (55.8)	28 (71.1)	14.8 (56)	750 (341)
AFF12	101.0 (256.5)	44.0 (111.7)	27.5 (69.8)	47.5 (120.6)	26.0 (66.0)	28 (71.1)	25.5 (97)	1300 (591)
AFF16	112.0 (284)	52.0 (132.0)	32.0 (81.3)	50.0 (127.0)	30.0 (76.2)	28 (71.1)	56.2 (213)	1700 (773)

### Materials of Construction

**Body:** Carbon Steel  
**Paint:** Epoxy Enamel (Gray)  
**Internals:** Epoxy powder painted carbon steel  
**Seals:** Inorganic flange gasket (single element vessels)  
 Fluorocarbon o-ring (multi element vessels)  
**Internal Coating:** Epoxy enamel

### Specifications

**Max Pressure:** Up to 220-250 PSIG (15.2-17.2 barg)  
 (Consult Flow Chart)  
**Max Temperature:** 225°F (107°C)  
**Meets A.S.M.E. Code, Section VIII, Division 1:**  
**Note: Consult factory for special requirements**

# Compressed Air Filters

## Balston High Pressure Compressed Air Filters

Balston high pressure compressed air filters offer exceptionally high efficiency coalescing filtration of compressed air at high flow rates. The housings are ASME Code stamped to 665 psig.

Since the coalesced liquid drains continuously from the filter cartridges as rapidly as it is collected, the filters have an unlimited capacity for liquid removal.

Each filter cartridge is mounted on a rigid permanent filter holder with a vibration-resistant removable tube retainer. The filter cartridge is self gasketing, and the filter holder is designed so that a perfect seal is easily made, even when the tube is replaced by an operator unfamiliar with the equipment.

AKH housings are available with inlet and outlet ports covering the range from 3" to 10" pipe sizes.



Model (5)	AKH-0280	AKH-0480	AKH-0880	AKH-1480	AKH-2280
Port Size	3" FLG	4" FLG	6" FLG	8" FLG	10" FLG
Materials of Construction					
Vessel	Carbon Steel	Carbon Steel	Carbon Steel	Carbon Steel	Carbon Steel
Filter Cartridge Holders	303 St. Steel	303 St. Steel	303 St. Steel	303 St. Steel	303 St. Steel
Seals	Buna-N	Buna-N	Buna-N	Buna-N	Buna-N
Maximum Temperature	250°F (121°C) (1)	250°F (14°C) (1)	250°F (121°C) (1)	250°F (121°C) (1)	250°F (121°C) (1)
Maximum Pressure	665 psig (45.9 barg) (2)	665 psig (45.9 barg) (2)	665 psig (45.9 barg) (2)	665 psig (45.9 barg) (2)	665 psig (45.9 barg) (2)
Minimum Pressure	10 psig (0.69 barg)	10 psig (0.69 barg)	10 psig (0.69 barg)	10 psig (0.69 barg)	10 psig (0.69 barg)
Shipping Weight	150 lbs. (68 kg)	270 lbs. (123 kg)	560 lbs. (254 kg)	1120 lbs. (508 kg)	1430 lbs. (649 kg)
Dimensions	16"W X 41"H (41cm X 104cm)	21"W X 40"H (53cm X 102cm)	25"W X 43"H (64cm X 109cm)	34"W X 54"H (86cm X 137cm)	36"W X 57"H (91cm X 145cm)
Flange Center Line to Floor Dimension	7.75" (20cm)	6.25" (16cm)	8.5" (22cm)	16.25" (41cm)	17.25" (44cm)
Flange to Flange Dimension	15.63" (40cm)	20.63" (52cm)	24.75" (63cm)	34" (86cm)	36" (91cm)

**For assistance, call toll-free at 1-800-343-4048 8AM to 5PM Eastern Time**

Model (3)	AKH-0280-□	AKH-0480-□	AKH-0880-□	AKH-1480-□	AKH-2280-□
Replacement Filter Cartridges					
No. Required	2	4	8	14	22
Box of 5	5/200-80-□ (4)	5/200-80-□ (4)	5/200-80-□ (4)	5/200-80-□ (4)	5/200-80-□ (4)
Box of 10	200-80-□ (4)	200-80-□ (4)	200-80-□ (4)	200-80-□ (4)	200-80-□ (4)
CI Cartridge (Box of 1)	CI-200-80-000	CI-200-80-000	CI-200-80-000	CI-200-80-000	CI-200-80-000

**Notes:**

1 Maximum operating temperature of carbon steel vessel is 650°F (343°C). Minimum operating (process and ambient pressure) temperature is -20°F (29°C). Max. Temps.

for Seal material: 250°F (Buna), 400°F (Viton), 450°F (Silicone). Seal material may not be the limiting factor. Maximum temperature for assemblies with DPI is 130°F (54°C)

2 Vessel is ASME Section VIII, Div. 1 code stamped for rated pressure.

3 Differential Pressure Indicator and Automatic Drain are not included with AKH Assemblies, or with assemblies containing Type CI Cartridges.

4 To order filter cartridges, indicate grade of filter cartridge by placing appropriate letter cartridge designation after the last digit. Example: 200-80-DX.

# Stainless Steel Compressed Air Filters for Harsh Environments

## Balston Stainless Steel Compressed Air Filter Assemblies:

Balston Compressed Air Filters protect your equipment and delicate instruments from the dirt, water, and oil usually found in compressed air and other gases. These filters will remove contaminants at a very high efficiency - up to 99.99% for 0.01 micron particles and droplets. Liquid releases from the filter cartridge to an automatic drain as rapidly as it enters the filter. This allows the filter to continue removing liquids for an unlimited time without loss of efficiency or flow capacity. Select 1/4" to 1" line filters are constructed of 304 stainless steel and are designed to hold up to the harshest environments.



## Product Features:

- All 304 stainless steel construction, ideal standing up to aggressive washdown chemicals
- Remove 99.99% of 0.01 micron particles of oil, water, and dirt from compressed air and other gases
- For Sterile Air Requirements:
- USDA accepted for use in federally inspected meat and poultry plants
- Low pressure drop
- Continuously trap and drain liquids
- Remove trace oil vapor with adsorbent cartridges

Petrochemical

Textiles

Pulp and Paper

Refineries



# Compressed Air Filters

## Stainless Steel Filters for Harsh Environments

### Filter Cartridge Description

<b>General purpose applications such as plant compressed air</b>	Single stage filtration. Use a Grade DX filter cartridge
<b>Instrument air and other critical air requirements</b>	Two stage filtration is necessary. Use a Grade DX followed by a Grade BX filter cartridge. As a general rule, a Grade BX filter cartridge should not be used alone.
<b>Removal of trace compressor oil vapor</b>	For rare instances where even a trace amount of oil vapor can cause a problem, three stage filtration is necessary. Use a Grade DX followed by a Grade BX, and a type CI cartridge.

### Physical Properties, Microfibre Filter Cartridges

<b>Temperature Range</b>	-40°F to 300°F (-40°C - 149°C)
<b>Maximum Pressure Differential Across Filter, Inside-to-Outside Flow:</b>	100 psi (7 barg)
<b>Materials of Construction</b>	Borosilicate glass microfibers with fluorocarbon resin binder. Resistant to water, all hydrocarbon and synthetic lubricants.

### Retention Efficiency

Grade	Efficiency for 0.01 Micron Particles and Droplets
DX	93%
BX	99.99%

### Balston Filter Cartridges

Balston provides two grades of coalescing filter cartridges, Grade DX and Grade BX. Singly or in tandem, these filters satisfy all requirements for removing liquid and solid contaminants from compressed air. Balston also has an activated carbon adsorbent CI-type cartridge for the removal of trace oil vapors from a compressed air line. The activated carbon cartridge is Grade 000.

### How to Select the Filter Cartridge and Housing

- 1 Decide which grade(s) of filter cartridges fits the application (see selection boxes at left).
- 2 Select the filter housing with a port size equal to the line size where the filter is to be located.
- 3 For a new installation in which the line size has yet to be selected, determine the gas flow rate and pressure at the point where the filter will be located, and then refer to the flow chart on the reverse side of this data sheet. NOTE: The filter port size must be equal to or larger than the line size (when specified).

### How to Order the Filter Assembly

- 1 Build your own custom filter assembly using the guideline matrix on Page 16 and specify your model number. Example: 1/2" filter with DPI and Auto Drain with Grade DX Filter = 6004N-01A-DX.
- 2 Each assembly is shipped with the filter cartridge installed. To order additional filter cartridges, indicate the model number of the cartridges, and the grade. Examples 050-05-DX, 050-05-BX. The grade used for Type CI cartridges is 000 (CI-100-12-000).

Note: Assemblies with CI Cartridges are shipped with the adsorbent cartridge wrapped separately. This shipping method prolongs the life of the cartridge.

# Compressed Air Filters

## Stainless Steel Filters for Harsh Environments

### Models 6102, 6002, 6904

The 6102 and 6002 series models are 1/4" line size filters designed for lower flow systems and installations with space limitations. It is offered with two drain options, a manual drain or an auto float drain for maintenance free operation. The model 6904 offers 1/2" inlet and outlet connections, for applications requiring 1/2" pipe with space limitation requirements.



Models 6102, 6002, 6904

Model 6004

### Model 6004

The 6004 series models are 1/2" line size filters designed for moderate flow rate systems. This series has increased liquid holding capacity which safeguards sensitive end use points from system upsets and morning start ups.

### Models 6006 and 6008

The 6006 and 6008 series models are 3/4" and 1" line size filters respectively. These are designed for high flow rate systems servicing multiple end use points. These are also offered with a high capacity auto float drain option.



Models 6006 and 6008

### How to Order the Filter Assembly\*

Build your own custom filter assembly using the guideline matrix below and specify your model number. Example: 1/2" filter with Auto Drain and Grade DX Filter = 6004N-0A1-DX.

\*Consult Factory. Not all configurations are available.

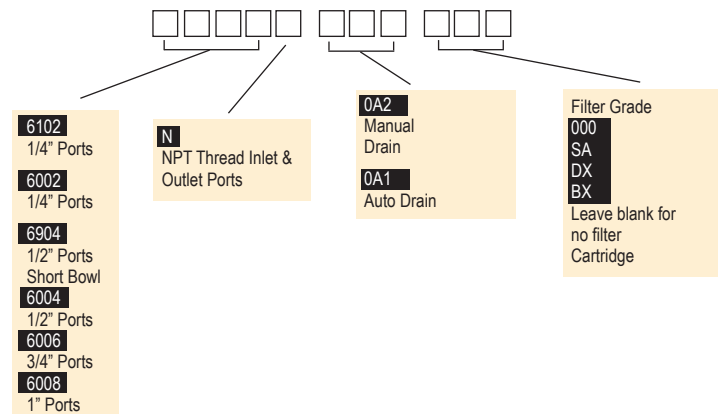

# Compressed Air Filters

## Stainless Steel Filters for Harsh Environments

Compressed Air Filters

### Flow Rates

Filter Housing Model	Port Size	Filter Cartridge Grade	Flow rates SCFM (Nm <sup>3</sup> /hr), at 7 psi drop at indicated line pressure (over 3 stages). Refer to Principal Specification Charts in each product data sheet for maximum pressure rating of each housing								
			2 (0.14)	20 (1.4)	40 (3)	80 (6)	100 (7)	125 (9)	150 (10)	200 (14)	250 (17)
6102N	1/4"	DX	3.5 (6)	8 (13)	11 (18)	20 (33)	25 (42)	30 (50)	36 (60)	---	---
		BX	1 (2)	2 (3)	3.5 (6)	5.7 (10)	6.8 (11)	8 (13)	10 (17)	---	---
6002N	1/4"	DX	9 (15)	19 (32)	39 (66)	51 (87)	63 (107)	76 (129)	90 (153)	117 (199)	145 (246)
6904N	1/2"	BX	3 (5)	8 (14)	11 (19)	21 (36)	25 (42)	31 (53)	36 (61)	47 (80)	58 (99)
		CI	2 (3)	5 (8)	7 (12)	12 (20)	15 (25)	18 (31)	22 (37)	28 (48)	35 (59)
		SA	---	8 (14)	11 (19)	21 (36)	25 (42)	31 (53)	36 (61)	---	---
6004N	1/2"	DX	19 (32)	41 (70)	65 (110)	113 (192)	137 (233)	166 (181)	196 (333)	257 (437)	316 (537)
		BX	9 (15)	19 (32)	30 (51)	51 (87)	63 (107)	76 (129)	90 (153)	117 (199)	145 (246)
		CI	6 (10)	12 (20)	19 (32)	32 (54)	39 (66)	48 (82)	56 (95)	73 (124)	90 (153)
		SA	---	19 (32)	30 (51)	51 (87)	63 (107)	76 (129)	90 (153)	---	---
6006N	3/4"	DX	37 (63)	78 (133)	123 (209)	214 (364)	259 (440)	315 (535)	371 (630)	484 (822)	596 (1013)
		BX	10 (17)	21 (36)	34 (58)	56 (95)	70 (119)	85 (144)	101 (172)	131 (223)	162 (275)
		CI	8 (14)	16 (27)	26 (44)	44 (75)	53 (90)	65 (110)	76 (129)	99 (168)	122 (207)
		SA	---	21 (36)	34 (58)	56 (95)	70 (119)	85 (144)	101 (172)	---	---
6008N	1"	DX	55 (93)	115 (195)	181 (308)	314 (533)	380 (646)	463 (787)	546 (928)	711 (1208)	877 (1490)
		BX	11 (19)	23 (39)	37 (63)	64 (109)	77 (131)	94 (160)	111 (189)	144 (245)	178 (302)
		CI	10 (17)	20 (34)	32 (54)	56 (95)	67 (114)	82 (139)	96 (163)	125 (212)	154 (262)
		SA	---	23 (34)	37 (70)	64 (116)	77 (144)	94 (177)	111 (209)	---	---

### Sterile Air Filters

Balston grade SA filter cartridges, rated at 99.9999+% efficiency for 0.01 micron particles, is at least 30 times better than the accepted standard for sterile air filters developed by independent research organizations in the U.S. and U.K. (request bulletin TI-105A for a detailed discussion on Balston filter efficiency rating procedure, and Bulletin TI-935 for an independent test report on balstonSterile Air Filters). Balston Sterile Air Filters are in full compliance with the requirements of the FDA.

### Steam Sterilization Procedure

In installations where the sterile air filter requires steam sterilization, we recommend the following procedures:

The steam sterilization pressure should not exceed 60 psig (4 barg). Preferably, it should be held to 40 psig (3 barg) or less. A typical sterilization cycle is 30 psig (2 barg) steam for 30 minutes. Steaming time can be increased as desired without harm to the filter cartridges. The steam flow should not exceed the normal air flow for the unit. To ensure no buildup of condensate in the housing, condensate should be drained from the filter by a condensate drain valve during the steaming process. The cleanliness of the steam is an important factor influencing the life of the Sterile Air Filter cartridges. Parker strongly recommends using Model 23 Steam Filters to ensure optimum operating life. When autoclaving, the Grade SA filter cartridges will tolerate temperatures to 300°F (149°C) in dry gas. Viton or other heat resistant seals should be used in the housing.

# Compressed Air Filters

## Stainless Steel Filters for Harsh Environments

### Principal Specifications

Model	6102	6002	6904	6004	6006	6008
Port Size	1/4" NPT	1/4" NPT	1/2" NPT	1/2" NPT	3/4" NPT	1" NPT
Materials of Construction						
Head	316 Stainless Steel	304 Stainless Steel				
Bowl	316 Stainless Steel	304 Stainless Steel				
Internals	Acetal	Stainless Steel				
Seals	Viton	Buna-N Food Grade				
Maximum Temperature	140°F (60°C) (1)	120°F (49°C) (1)				
Maximum Pressure	150 psig (12.1 barg) (2)	175 psig (10.3 barg) (2)				
Minimum Pressure	15 psig (1 barg) (3)	15 psig (1 barg) (3)				
Shipping Weight	3.5 lbs. (1.6 Kg)	3.5 lbs. (1.6 Kg)	3.5 lbs. (1.6 Kg)	4.0 lbs. (1.8 Kg)	11 lbs. (4.9 Kg)	12 lbs. (5.4 Kg)
Dimensions	1.5"W x 4.2"L (3.8cm x 11.7cm)	3"W X 7"L (7cm X 18cm)	3"W X 7"L (7cm X 18cm)	3"W X 10"L (7cm X 25cm)	4"W X 10"L (10cm X 25cm)	4"W X 12"L (10cm X 30cm)

**Notes:**

- 1 Max. temperature with auto drain. Max. temperature with manual drain is 275°F (135°C).      2 Max. pressure with auto drain. Max. pressure with manual drain is 250 psi (17 barg).      3 Required for proper operation of auto drain.

### Ordering Information For assistance, call toll-free at 1-800-343-4048 8AM to 5PM Eastern Time

Assembly Ordering Information					
Model P/N	Filter Tube	Drain (Manual)	Drain (Auto. Float)	Mounting Bracket (stainless steel)	
6102N-0A0-(?X)	070-063-(?X)	SAP05481	N/A	N/A	
6102N-0A1-(?X)	070-063-(?X)	N/A	C02-2392	N/A	
6002N-0A2-(?X)	100-12-(?X)	C01-0108	N/A	C01-0094	
6002N-0A1-(?X)	100-12-(?X)	N/A	C01-0109	C01-0094	
6002N-0A2-SA	100-12-SA	C01-0108	N/A	C01-0094	
6002N-0A2-000	CI-100-12-000	C01-0108	N/A	C01-0094	
6904N-0A2-(?X)	100-12-(?X)	C01-0108	N/A	C01-0094	
6904N-0A2-(?X)	100-12-(?X)	N/A	C01-0109	C01-0094	
6904N-0A2-SA	100-12-SA	C01-0108	N/A	C01-0094	
6904N-0A2-000	CI-100-12-000	C01-0108	N/A	C01-0094	
6004N-0A2-(?X)	100-18-(?X)	C01-0108	N/A	C01-0094	
6004N-0A1-(?X)	100-18-(?X)	N/A	C01-0109	C01-0094	
6004N-0A2-SA	100-18-SA	C01-0108	N/A	C01-0094	
6004N-0A2-000	CI-100-18-000	C01-0108	N/A	C01-0094	
6006N-0A2-(?X)	200-176-(?X)	C01-0108	N/A	C01-0094	
6006N-0A1-(?X)	200-176-(?X)	N/A	C01-0109	C01-0094	
6006N-0A2-SA	200-176-SA	C01-0108	N/A	C01-0094	
6006N-0A2-000	200-176-000	C01-0108	N/A	C01-0094	
6008N-0A2-(?X)	200-185-(?X)	C01-0108	N/A	C01-0094	
6008N-0A1-(?X)	200-185-(?X)	N/A	C01-0109	C01-0094	
6008N-0A2-SA	200-185-SA	C01-0108	N/A	C01-0094	
6008N-0A2-000	200-185-000	C01-0108	N/A	C01-0094	
Replacement Filter Cartridge Ordering Information					
Model P/N	6102	6002/6904	6004	6006	6008
Replacement Filter Cartridges					
Number required	1	1	1	1	1
Box of 5	5/070-063-(?X)	5/100-12-(?X)	5/100-18-(?X)	5/200-176-(?X)	5/200-185-(?X)
Box of 10	070-063-(?X)	100-12-(?X)	100-18-(?X)	200-176-(?X)	200-185-(?X)
Box of 10	070-063-SA	100-12-SA	100-18-SA	200-176-SA	200-185-SA
CI Cartridges (box of 1)	---	CI100-12-000	CI100-18-000	CI200-176-000	CI200-185-000

# Compressed Air Filters

## Disposable Filter Silencers

Compressed Air Filters

### Models 9955-05-DX, 9955-11-DX, 9955-12-DX, AR-009-DX

Balston Filter/Silencers for air exhausts offer the combination of unusually effective sound attenuation and filtration of all visible oil mist from the exhaust air. The Filter/Silencers are available in 1/8", 1/4", 1/2", and 3/4" port sizes. They contain a Grade DX Microfiber Filter Cartridge sealed into a molded nylon or steel holder.

Balston Filter/Silencers are remarkably efficient sound mufflers, far more efficient than the felts, pleated paper, sintered plastic, and sintered metal products commonly used in other exhaust silencers. A sound attenuation efficiency test comparing a 9955-12-DX, 1/2" Filter/Silencer with a sintered polyethylene silencer is described below.

This silencing efficiency test simulates the action of an air cylinder discharging rapidly to atmosphere. A length of 1/2" line between two ball valves is pressurized with air to a controlled pressure. The upstream valve is closed and then the downstream valve is opened rapidly to discharge the fixed volume of air under pressure to atmosphere. Noise levels were measured at a 3 foot (1 meter) distance with no silencer on the end of the line, with the Balston Filter Silencer, and with competitive silencers.



Model 9955-05-DX



Model 9955-11-DX



Model 9955-12-DX



Model AR-009-DX

Noise Level (dBA)	Upstream Pressure psig (barg)				
	100 (7)	80 (5.5)	60 (4.3)	40 (2.7)	20 (1.5)
Without Silencer	102	102	101	99	95
With Balston Silencer	70	70	69	67	65
With Sintered Polyethylene Silencer	88	88	87	87	81

A similar test of the Model AR-009-DX on a 3/4" air line gave the following results:

#### Sound Level 3 ft. from 3/4" Air Line Discharging Air At 100 PSIG Atmosphere

Without Silencer	With Model AR-009-DX
113 dBA	94 dBA



# Compressed Air Filters

## Disposable Filter Silencers

### Principal Specifications

Model	9955-05-DX	9955-11-DX	9955-12-DX	AR-009-DX
Inlet Port	1/8" NPT (Male)	1/4" NPT (Male)	1/2" NPT (Male)	3/4" NPT (Female)
Drain Port	1/4" OD Tubing	1/4" OD Tubing	1/4" OD Tubing	1/8" NPT (Female)
Materials of Construction	Borosilicate glass microfibers with fluorocarbon resin binder			
Filter Cartridge	Borosilicate glass microfibers with fluorocarbon resin binder			
Holder	Nylon	Nylon	Nylon	Aluminum
Internals	—	—	—	Aluminum
Maximum Internal Pressure at 110°F (43°F)	100 psig (7 barg) (1)	100 psig (7 barg) (1)	100 psig (7 barg) (1)	100 psig (7 barg) (1)
Maximum Temp. at 0 psig Internal Pressure	260°F (127°C)	260°F (127°C)	260°F (127°C)	300°F (149°C)
Shipping Weight	0.5 lb (0.2 kg)	0.5 lb (0.2 kg)	0.5 lb (0.2 kg)	1 lb (0.5 kg)
Dimensions	1.4" dia. X 2.0"h (4cm X 5cm)	1.4" dia. X 3.0"h (4cm X 8cm)	2.0" dia. X 3.7"h (5cm X 9cm)	3.95" dia. X 5.13"h (10cm X 13cm)

**Notes:**

1 With the outlet open to atmosphere. Otherwise, maximum internal pressure is 15 psig.

### Ordering Information

**For assistance, call toll-free at 1-800-343-4048 8AM to 5PM Eastern Time**

Model	Description
9955-05-DX, 9955-11-DX, 9955-12-DX	Standard Pack 10 Filter Silencers per box, individually wrapped
AR-009-DX	Complete Assembly with one filter element
Replacement Element for AR-009-DX 2/BE200-168-DX BE200-168-DX	Boxes of 2 Boxes of 10

**Table 1**

**Flow Rate from Pressured Line through Filter to Atmosphere (cu. ft. per sec.)**

Filter Housing Type	100 psig (6.9 barg) Line Pressure	60 psig (4.1 barg) Line Pressure	20 psig (1.4 barg) Line Pressure
9955-05-DX	3 (4.9)	1.2 (2.5)	0.2 (0.7)
9955-11-DX	10 (16.2)	4 (8.2)	0.7 (0.5)
9955-12-DX	35 (57)	14 (29)	2.2 (1)
AR-009-DX	105 (171)	42 (86)	6.6 (4)

# Low Flow, Compact Compressed Air Filters



## Balston 92-800 Series Compressed Air and Gas Filters

Safeguard critical end use points from water, oil, rust and pipescale. The 92-800 series compressed air filters are small and compact making them ideal for portable pneumatics, instrumentation, and other applications requiring small pneumatic components.

The 92-800 Series are available with anodized aluminum heads and polycarbonate bowls, anodized aluminum bowls, or pyrex glass bowls. Capable of up to 250 PSIG and 250°F, these filters can be applied to the most demanding applications. High efficiency filtration media is available from 93% at 0.01 micron to 99.9999+% at 0.01 micron.

The 92-800 series are available with 1/4" and 1/2" NPT connections.



### Applications

These filters are ideal for safeguarding critical production equipment from corrosive compressor condensate that can cause catastrophic failures and unexpected shutdowns. Ideal applications are:

- Instrumentation
- Air actuators and air cylinders
- Pneumatic packaging machines
- Pneumatic conveyors
- Air operated production equipment
- Air operated lifts

### Product Features

- Small compact design
- Anodized aluminum with polycarbonate, Pyrex, or aluminum bowls
- Continuously trap and drain liquids
- Remove up to 99.9999+% of 0.01 micron particles of oil, water, and dirt from compressed air and other gases
- High flow rate capacity
- Low pressure drop

The Parker Balston 92-800 Series offer the best protection to all your pneumatic equipment and instrumentation. These high efficiency filtration systems will eliminate costly maintenance and unexpected downtime due to contaminated compressed air.

# Low Flow, Compact Compressed Air Filters

## Principal Specifications and Ordering Information



92-810A



92-810

Filter Housing Model	Port Size	Filter Cartridge Grade	Flow rates SCFM (Nm <sup>3</sup> /hr), at 2 psi drop at indicated line pressure. Refer to Principal Specification Charts in each product data sheet for maximum pressure rating of each housing								
			2 (0.14)	20 (1.38)	40 (2.76)	80 (5.52)	100 (6.9)	125 (8.6)	150 (10.3)	200 (13.8)	250 (17.2)
Series 92-810/2	1/4"	DX	12 (20.4)	26 (44.2)	40 (68.0)	70 (118.9)	85 (144.4)	103 (175.0)	122 (207.3)	159 (270.1)	196 (333.0)
	1/2"	BX	3 (5.1)	7 (11.9)	10 (17.0)	18 (30.6)	22 (37.4)	27 (45.9)	32 (54.4)	41 (69.7)	51 (86.6)

### Principal Specifications

Model (1)	92-810A	92-810
Port Size	1/4" NPT	1/4" NPT
Material of Construction		
Head	Aluminum	Aluminum
Bowl	Aluminum	Polycarbonate
Internals	Aluminum	Aluminum
Seals	Buna-N Grade	Buna-N Grade
Maximum Temperature	250°F (121°C)	130°F (54°C)
Maximum Pressure	250 psig (17 barg)	150 psig (10 barg)
Shipping Weight	2 lbs. (0.9 kg)	2 lbs. (0.9 kg)
Dimensions	2.75"W x 5.64"L (7cm W x 14cm L)	2.75"W x 5.64"L (7cm W x 14cm L)

### Ordering Information for assistance, please call 1-800-343-4048 8AM to 5PM Eastern Standard Time

Model P/N (2)	Description	Replacement Cartridge	
		Box of 2	Box of 10
92-810A	1/4" NPT Ports with Aluminum Bowl	2/100-12-?X	100-12-?X
92-812A	1/2" NPT Ports with Aluminum Bowl	2/100-12-?X	100-12-?X
92-810	1/4" NPT Ports with Polycarbonate Bowl	2/100-12-?X	100-12-?X
92-812	1/2" NPT Ports with Polycarbonate Bowl	2/100-12-?X	100-12-?X

**Notes:**

- 1 For 1/2" NPT Ports, order 92-812
- 2 Filter housings are not supplied with filter cartridges

# Compressed Air Filters

## Filter Regulators

Compressed Air Filters

### Filter-Regulator Combinations

Balston Filter-Regulators combine a high efficiency coalescing filter with a high quality pressure regulator. Air flows through the filter, then to the pressure regulator. The filter is a Balston coalescing compressed air filter (Grade BX) and will completely remove oil, water, and dirt from compressed air and other compressed gases. Flow direction through the element is inside-to-outside for optimum oil and water removal. An automatic drain is installed on the 3/8", 1/2", and 3/4" models offering maintenance-free operation. Pressure gauges are standard and are available in up to 4 different ranges (see ordering information).



AFR-940, AFR-940A



12E Series

### Control Characteristics

Model AFR-940, AFR-940A

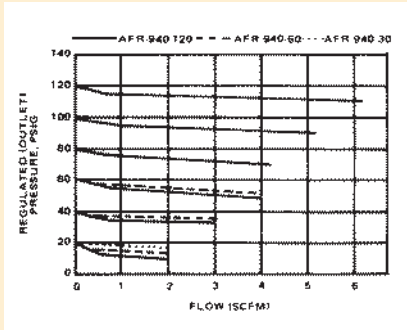

Model 12E

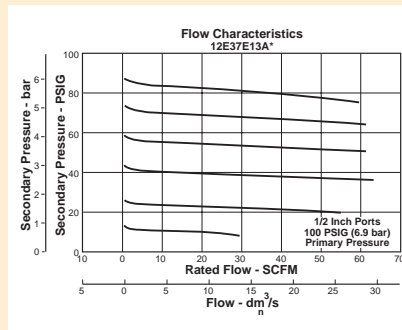

# Compressed Air Filters

## Filter Regulators

### Principal Specifications

Model	AFR-940	AFR-940A	12E37	12E47
Port Size	1/4" NPT	1/4" NPT	1/2" NPT	3/4" NPT
Gauge Ports	1/8" NPT	1/8" NPT	1/4" NPT	1/4" NPT
Materials of Construction				
Head	Anod. Alum.	Anod. Alum.	Zinc	Zinc
Bowl	Polycarb.	Anod. Alum.	Zinc	Zinc
Bonnet	Polycarb.	Polycarb.	Plastic	Plastic
Internals	Brass/Buna	Brass/Buna	Zinc/Nitrile	Zinc/Nitrile
Maximum Temperature	220°F (104°C)	220°F (104°C)	125°F (52°C)	125°F (52°C)
Maximum Pressure	150 psig (10.3 barg) (2)	250 psig (17.2 barg) (2)	250 psig (17.2 barg) (2)	250 psig (17.2 barg) (2)
Minimum Pressure	—	—	15 psig/1.03 barg (1)	15 psig/1.03 barg (1)
Shipping Weight	0.5 lbs. (0.2 kg)	0.5 lbs. (0.2 kg)	2.5 lbs. (1.1 kg)	2.5 lbs. (1.1 kg)
Dimensions	1.2"W X 6"L (3cm X 15cm)	1.2"W X 6"L (3cm X 15cm)	3.25"W X 13"L (8cm X 33cm)	3.25"W X 13"L (8cm X 33cm)

### Ordering Information

For assistance, call toll-free at 1-800-343-4048 8AM to 5PM Eastern Time

Model	AFR-940	AFR-940A	12E37	12E47
Control Gauge Pressure Range				
0-30 psig	AFR-940-30	AFR-940A-30	see ordering matrix below	→
5-60 psig	AFR-940-60	AFR-940A-60	see ordering matrix below	→
10-130 psig	AFR-940-130	AFR-940A-130	see ordering matrix below	→
Auto. Drain	N/A (1)	N/A (1)	Included (1)	Included (1)
Replacement Filter Cartridges				
Number Required	1	1	1	1
Box of 5	5/050-05-BX	5/050-05-BX	5/130-14-BX	5/130-14-BX
Box or 10	050-05-BX	050-05-BX	130-14-BX	130-14-BX
Mounting Bracket	11536	11536	PS807P	PS807P

#### Notes:

- 1 Minimum operating pressure for automatic drain is 15 psig (1.03 barg).
- 2 Maximum pressure ratings are for tem-

peratures to 130°F (54°C). Please consult the factory for maximum pressure ratings at elevated temperatures.

### How to Order

To order product with desired port size and Regulating Pressure Range, select the indicator digits from the matrix (at right). This will complete the entire model number which is needed to place an order.

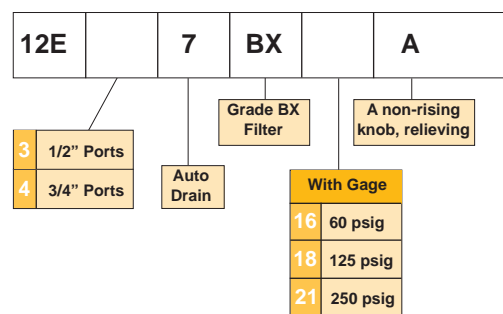

# Compressed Air Filters

## Mist Lubricators

### Model 17L Series

Many pneumatic system components and most tools require oil lubrication for proper operation and long service life. This lubricant is typically carried by the air stream. Too little oil can cause excessive wear and premature failure. Too much oil is wasteful and can become a contaminant. Use of the proper lubricator can greatly extend the life of expensive downstream pneumatic equipment.

The 17L Series Micro-Mist Lubricators offer proportional oil delivery over a wide range of air flows. The precision needle valve assures repeatable oil delivery and provides simple adjustment of delivery rate. They are designed to generate oil droplets of 5 microns or smaller downstream to lubricate systems having complex piping arrangements. The 17L series are ideal for low and high flow applications with changing air flow.



17L Series

### How to Select the Correct Lubricator

Once the required flow is determined for a pneumatic application, the lubricator can be selected by using the flow chart. To read the lubricator flow chart, first determine the inlet pressure that will be used. Find the appropriate pressure curve on the graph. Each graph will contain three pressure curves. If the required inlet pressure is not on the graph, interpolate a similar curve for the required pressure.

Next, determine the acceptable pressure drop across the lubricator and locate it on the vertical axis. Find the intersection point of the acceptable pressure drop and the inlet pressure curve. At this point, follow a vertical path downward to view the flow in SCFM. If the flow is too low, select a larger port size or body size to give the required flow. If the flow is higher than necessary, select a smaller port size or body size to give the required flow.

Model 17L22B

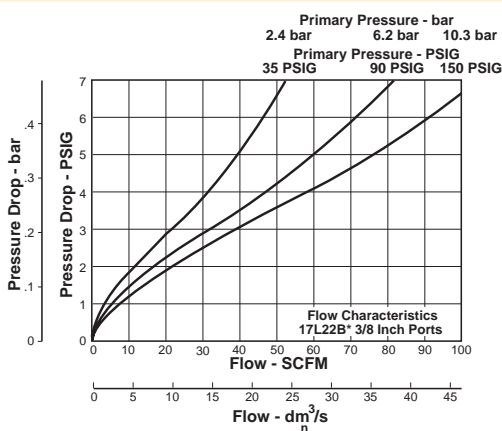

Model 17L32B and 17L42B

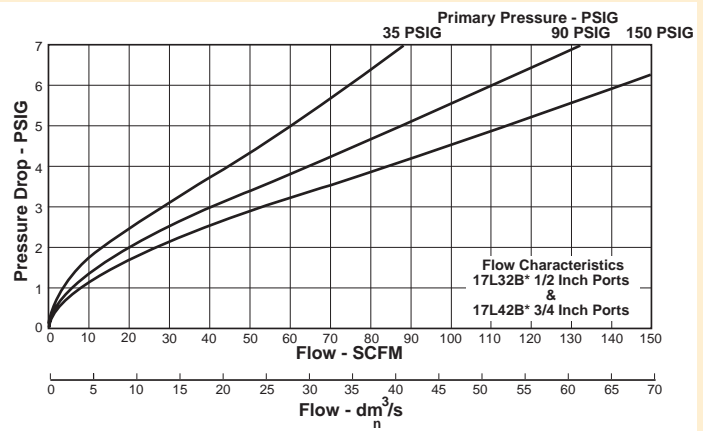

# Compressed Air Filters

## Mist Lubricators

### Principal Specifications

Model	17L22BE	17L32BE	17L42BE
Port Size	3/8" NPT	1/2" NPT	3/4" NPT
Gauge Ports	1/4" NPT	1/4" NPT	1/4" NPT
Materials of Construction			
Head	Zinc	Zinc	Zinc
Bowl	Polycarbonate	Polycarbonate	Polycarbonate
Bowl Guard	Steel	Steel	Steel
Collar	Plastic	Plastic	Plastic
Seal	Nitrile	Nitrile	Nitrile
Sight Dome	Polycarbonate	Polycarbonate	Polycarbonate
Sight Gage	Polyamide	Polyamide	Polyamide
Maximum Temperature	125°F (52°C)	125°F (52°C)	125°F (52°C)
Maximum Pressure	150 psig (10.3 barg)	150 psig (10.3 barg)	150 psig (10.3 barg)
Minimum Pressure	15 psig (1.03 barg)	15 psig (1.03 barg)	15 psig (1.03 barg)
Shipping Weight	1.9 lbs. (0.9 kg)	1.9 lbs. (0.9 kg)	1.9 lbs. (0.9 kg)
Dimensions	3.25"W X 9.27"L (85mm X 235mm)	3.25"W X 9.27"L (85mm X 235mm)	3.25"W X 9.27"L (85mm X 235mm)

### Ordering Information

For assistance, call toll-free at 1-800-343-4048 8AM to 5PM Eastern Time

Model	17L22BE (3/8"NPT)	17L32BE (1/2"NPT)	17L42BE (3/4"NPT)
Service Kit	PS748P	PS748P	PS748P

# Compressed Air Filters

## Selection Chart Prep-Air® II Air Preparation Units

### Product Selection Chart

Basic Unit	Series	Port Size (inches)											Bowls			Capacity	Elements (Micron)	Page		
		1/8	1/4	3/8	1/2	3/4	1	1-1/4	1-1/2	2	2-1/2	3	Poly	Metal	Metal SG		5			
FILTERS	FF10				X										316 Stainless Steel			4 oz. (113 ml)	Standard	37
	10F	X	X												X	X	X	1 oz. (28 ml)	Grade 6 Std., Grade 10 Opt.	39
COALESCERS	FF501		X												316 Stainless Steel			1 oz. (28 ml)	Grade 6	41
	FF11				X										316 Stainless Steel			4 oz. (113 ml)	Grade 6	43

Basic Unit	Series	Port Size (inches)							Spring	Page
		1/8	1/4	3/8	1/2	3/4	1	1-1/2	125	
REGULATORS	FR364		X						Standard	45
	05R		X	X					Standard	47
	FR10				X				Standard	49
	07R			X	X	X			Standard	51
	P3NR					X	X	X	Standard	53

\*Sight gauge



# Compressed Air Filters

## Selection Chart Prep-Air® II Air Preparation Units

### Product Selection Chart

Basic Unit	Series	Port Size							Bowls			Capacity	Elements (Micron)	Spring Range	Page
		1/8	1/4	3/8	1/2	3/4	1	1-1/2	Poly	Metal	Metal SG		5	125	
F I L T E R / R E G U L A T O R S	14E	X	X						X	X	N/A	1 oz. (28 ml)	Standard	Standard	55
	FB548		X						316 Stainless Steel			1 oz. (28 ml)	Standard	Standard	57
	06E		X	X	X				X	X	X	4.4 oz. (125 ml)	Standard	Standard	59
	FB11				X				316 Stainless Steel			4 oz. (113 ml)	Standard	Standard	61

\*Sight gauge

# Compressed Air Filters

## Air Preparation Units - Drains

### Automatic Pulse Drain

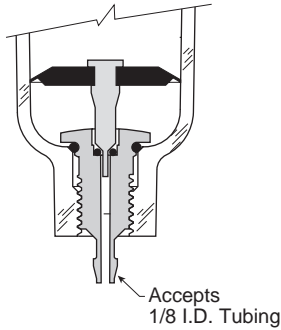

#### (Spitter Drain)

The diaphragm in this drain pulses when there is a pressure differential such as a valve cycling or cylinder stroking downstream. This action flexes the diaphragm and allows the filter to drain the entrapped water.

### Automatic Float Drain

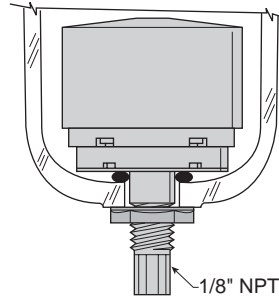

The float internal to this drain rises with increased liquid level. When the float rises, it opens a seat area allowing the trapped liquids to drain through the bottom. A manual override can be pushed in the bottom of the drain to unseat the float if particulates create a block.

# Compressed Air Filters

## Air Preparation Units - FF10 Filter - Standard 1/2" NPT Ports

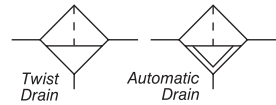

### Features

- Stainless steel construction handles most corrosive environments.
- Meets NACE specifications MR-01-75/ISO 15156.
- 1/8" female threaded drain.
- High Flow: 1/2" - 70 SCFM (119 Nm<sup>3</sup>/hr)<sup>§</sup>

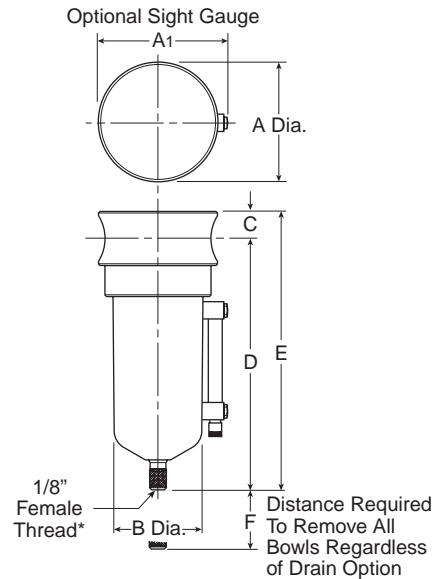

Port Size	NPT without sight gauge		NPT with sight gauge	
	Manual Twist Drain	Automatic Float Drain	Manual Twist Drain	Automatic Float Drain
1/2"	FF10-04DGSS	FF10-04DGRSS	FF10-04WGSS	FF10-04WGRSS

F10 Filter Dimensions		
<b>A</b> 2.38 (60)	<b>A1</b> 2.50 (64)	<b>B</b> 1.75 (44)
<b>C</b> .56 (14)	<b>D</b> 5.00 (127)	<b>E</b> 5.56 (141)
<b>F</b> 2.12 (54)		

<sup>§</sup> SCFM = Standard cubic feet per minute at 90 PSIG inlet and 5 PSIG pressure drop.  
Nm<sup>3</sup>/hr= Normal cubic meters per hour.

inches  
(mm)

### Ordering Information

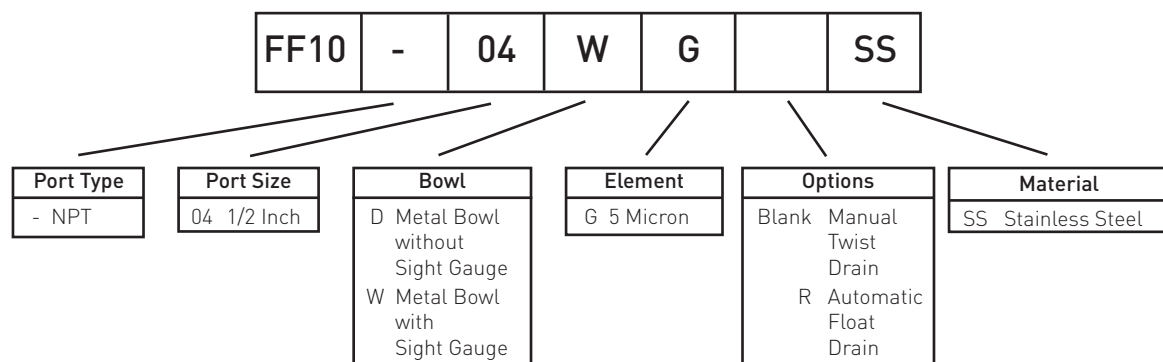

# Compressed Air Filters

## Air Preparation Units - FF10 Air Line Filters

### Technical Information

Compressed Air Filters

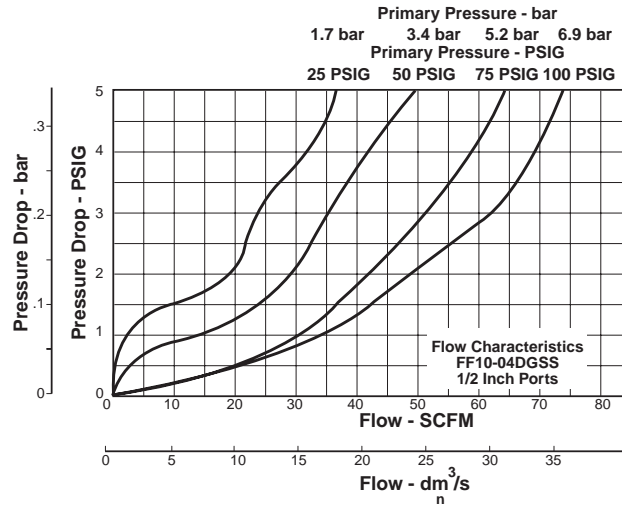

### FF10 Filter Kits & Accessories

Drain Kit -	
Automatic Float Drain .....	SA602MDSS
Manual Twist Drain-	
Small (Old) .....	SA600Y7-1SS
Large (New) .....	SAP05481
Filter Element Kits -	
Particulate (5 Micron) Element .....	EK55G
Pipe Nipple - 1/2" 316 Stainless Steel .....	616A28-SS

### Specifications

Bowl Capacity .....	4.0 Ounces (28 ml)
Filter Rating .....	5 Micron
Sump Capacity .....	1.7 Ounce
Port Threads .....	1/2 Inch
Pressure & Temperature Ratings -	
Manual Twist Drain (D-Bowl) .....	0 to 300 PSIG (0 to 20.7 bar)
	0°F to 180°F (-18°C to 82°C)
Manual Twist Drain (W-Bowl) .....	0 to 250 PSIG (0 to 17.2 bar)
	0°F to 150°F (-18°C to 66°C)
Automatic Float Drain .....	15 to 175 PSIG (1 to 12 bar)
	40°F to 125°F (4°C to 52°C)

Note: Air must be dry enough to avoid ice formation at temperatures below 32°F (2°C).

Weight .....

### Materials of Construction

Body .....	316 Stainless Steel
Bowls .....	316 Stainless Steel
Deflector .....	Acetal
Drain .....	316 Stainless Steel
Element Holder .....	Acetal
Filter Element .....	Polyethylene
Seals .....	Fluorocarbon
Sight Gauge .....	Isoplast

# Compressed Air Filters

## Air Preparation Units - 10F Coalescing Filters - Miniature 1/8", 1/4" Basic 1/8" Body

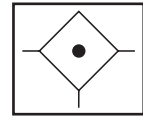

### Features

- Removes liquid aerosols and sub-micron particles.
- Liquids gravitate to the bottom of the element and will not re-enter the airstream.
- Oil free air for critical applications, such as air gauging and pneumatic instrumentation and controls.
- Interchangeable twist and automatic pulse drains.
- Grade 6 element, 99.97% DOP efficiency.
- High Flow:
  - Grade 6 Element
    - 1/8" – 17 SCFM (29 Nm<sup>3</sup>/hr) §
    - 1/4" – 20 SCFM (34 Nm<sup>3</sup>/hr) §
  - Grade 10 Element
    - 1/8" – 19 SCFM (32 Nm<sup>3</sup>/hr) §
    - 1/4" – 24 SCFM (41 Nm<sup>3</sup>/hr) §

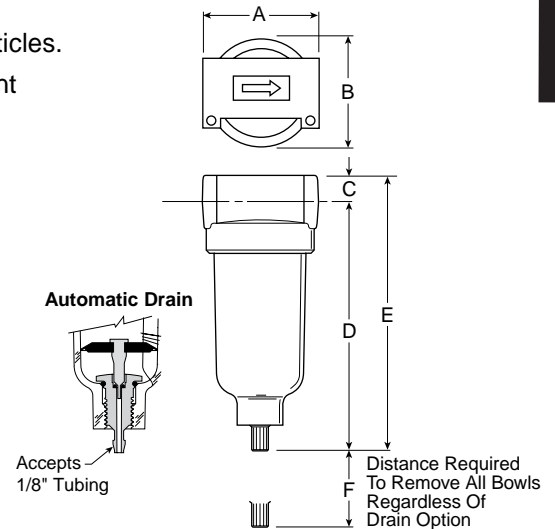

Port Size	NPT	
	Twist Drain	Automatic Pulse Drain
Poly Bowl ‡		
1/8"	<b>10F01E*</b>	<b>10F05E*</b>
1/4"	<b>10F11E*</b>	<b>10F15E*</b>
Metal Bowl without Sight Gauge		
1/8"	<b>10F03E*</b>	<b>10F07E*</b>
1/4"	<b>10F13E*</b>	<b>10F17E*</b>

10F Coalescing Filter Dimensions		
<b>A</b>	<b>B</b>	<b>C</b>
1.69 (43)	1.56 (39,6)	0.39 (10)
<b>D</b>	<b>D†</b>	<b>E</b>
3.82 (97)	3.67 (93)	4.21 (107)
<b>E†</b>	<b>F</b>	
4.06 (103)	1.60 (41)	

Standard part numbers shown bold, with Grade 6 Elements (for Grade 10 Elements, replace "E" with "H" in the 6th position). For other models refer to ordering information below.

‡ For polycarbonate bowl see Caution on page 2.

§ SCFM = Standard cubic feet per minute.  
Nm<sup>3</sup>/hr = Normal cubic meters per hour.

Inches (mm)

† With Automatic Pulse Drain.

### Ordering Information

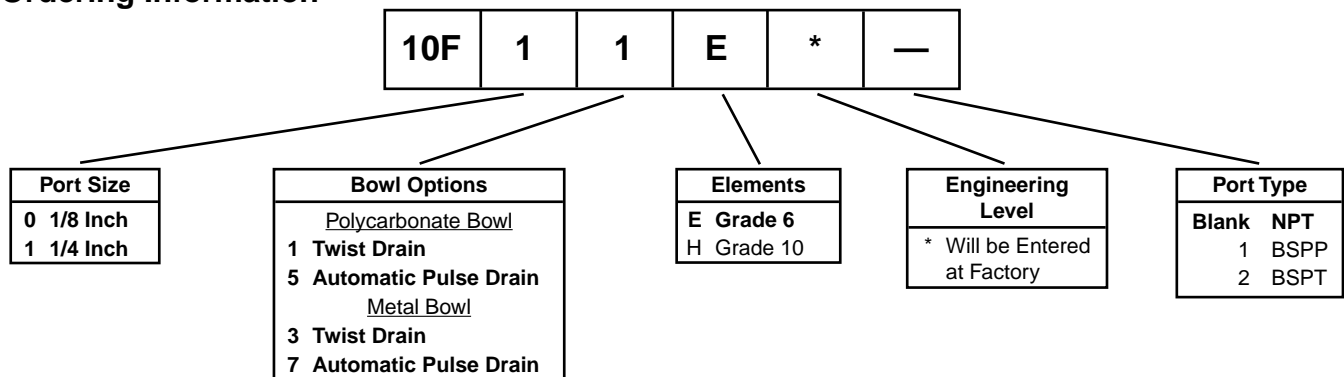

# Compressed Air Filters

## Air Preparation Units - 10F Coalescing Filters

### Technical Information

#### Grade 6

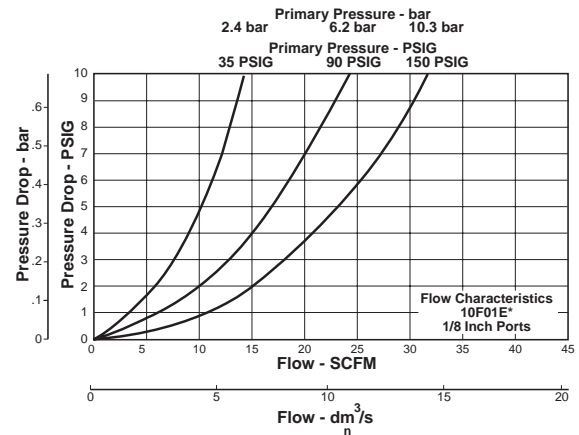
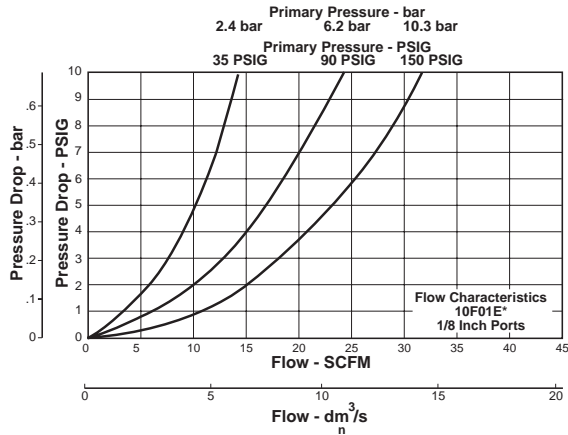

#### Grade 10

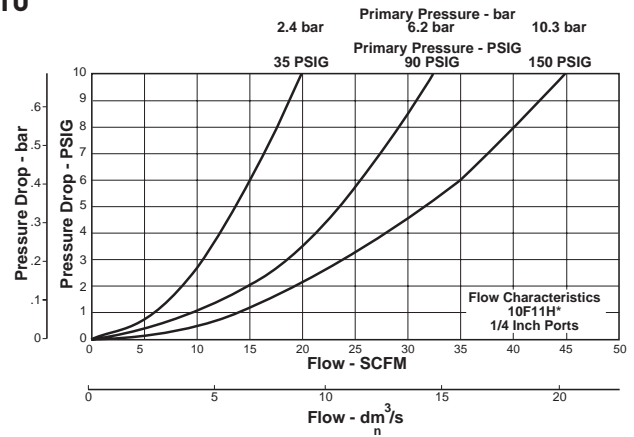
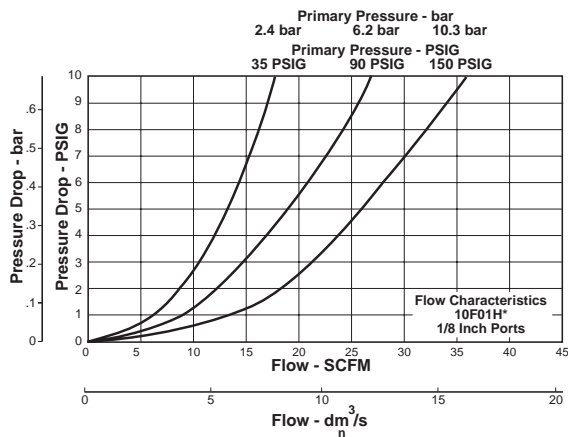

#### 10F Coalescing Filter Kits & Accessories

Bowl Kits -	
Poly Bowl - Automatic Pulse Drain.....	PS408BP
Twist Drain.....	PS404P
Metal Bowl - Automatic Pulse Drain.....	
Twist Drain .....	PS447BP
Filter Element Kits - Grade 6 (Standard) .....	
Grade 10 (Optional) .....	PS446P
Mounting Bracket Kit .....	
PS417BP	

#### Specifications

Automatic Pulse Drain Tube Barb.....	1/8 Inch
Bowl Capacity .....	1 Ounce (28 ml)
Operation -	
Normal Operating Pressure Drop .....	2 PSIG (0.14 bar)
Maximum Recommended Pressure Drop .....	10 PSIG (1.03 bar)
(Element should be replaced)	
Port Threads .....	1/8, 1/4 Inch
Pressure & Temperature Ratings -	
Polycarbonate Bowl.....	0 to 150 PSIG (0 to 10.3 bar)
	32°F to 125°F (0°C to 52°C)
Metal Bowl.....	0 to 250 PSIG (0 to 17.2 bar)
	32°F to 175°F (0°C to 80°C)
Automatic Pulse Drain.....	10 to 250 PSIG (0.7 to 17.2 bar)
	at 125°F (52°C) or less
Weight .....	0.41 lb. (0.18 kg)

#### Materials of Construction

Body .....	Zinc
Bowls .....	Transparent Polycarbonate
	Metal (Zinc) Without Sight Gauge
Drains - Twist Drain -	
Body & Stem .....	Plastic
Seals.....	Nitrile
Automatic Pulse Drain -	
Piston & Seals.....	Nitrile
Stem, Seat, Adaptor & Washers .....	Aluminum
Element Holder .....	Plastic
Filter Element -	
Borosilicate & felt glass fibers	99.97% DOP efficiency
Largest Aerosol Particle Passed (Grade 6) .....	0.01 Micron
Largest Solid Particle Passed (Grade 6) .....	0.30 Micron
Seals .....	Nitrile

# Compressed Air Filters

## Air Preparation Units

### FF501 Coalescing Filter - Miniature 1/4" Ports

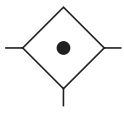

#### Features

- Stainless steel construction handles most corrosive environments.
- Meets NACE specifications MR-01-75/ISO 15156.
- 1/8" female threaded drain\*.
- High Flow: 1/4" - 16 SCFM (27 Nm<sup>3</sup>/hr)<sup>§</sup>

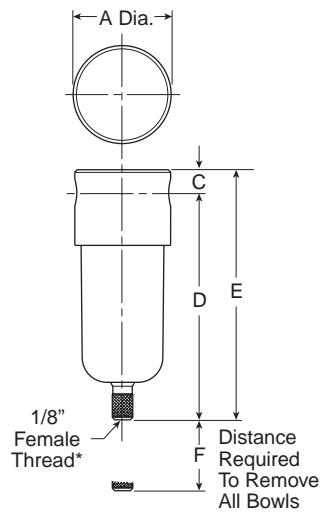

Port Size	NPT
	Manual Twist Drain
1/4"	<b>FF501-02DHSS</b>

F501 Coalescing Filter Dimensions		
<b>A</b>	<b>C</b>	<b>D</b>
1.56 (40)	0.31 (8)	3.69 (94)
<b>E</b>	<b>F</b>	
4.00 (102)	1.58 (40)	

inches  
(mm)

Standard part numbers shown bold. For other models refer to ordering information below.

<sup>§</sup> SCFM = Standard cubic feet per minute.  
Nm<sup>3</sup>/hr= Normal cubic meters per hour.

#### Ordering Information

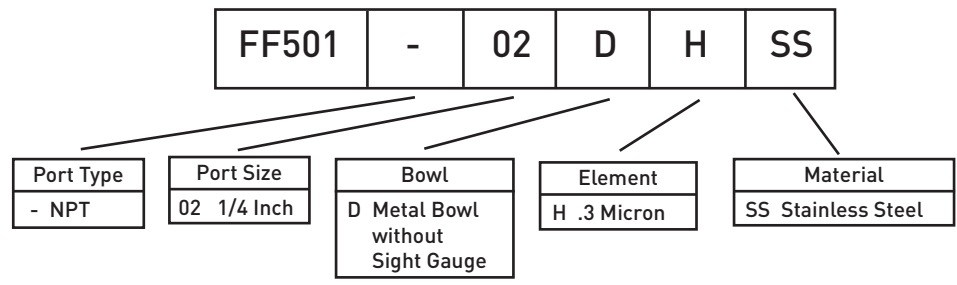

# Compressed Air Filters

## Air Preparation Units - F501 Series Technical Information

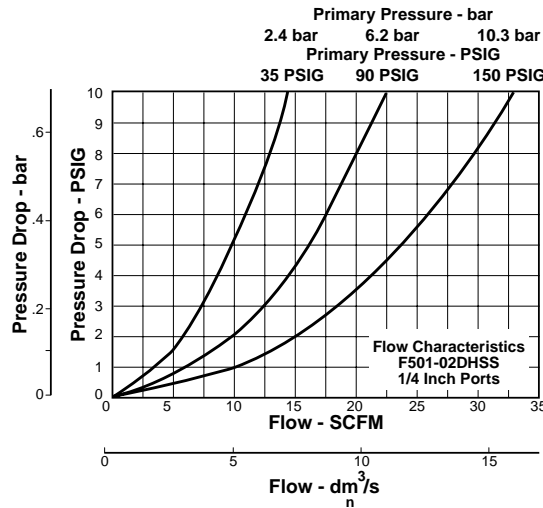

### FF501 Filter Kits & Accessories

Filter Element Kits -	
0.3 Micron .....	EKF31
Manual Twist Drain -	
Small (Old) .....	SA600Y7-1SS
Large (New) .....	SAP05481
Pipe Nipple -	
1/4" 316 Stainless Steel .....	616Y28-SS

### Specifications

Bowl Capacity .....	1.0 Ounces (28 ml)
Filter Rating .....	0.3 Micron
Port Threads .....	1/4 Inch
Pressure & Temperature Ratings -	
Manual Twist Drain .....	0 to 300 PSIG (0 to 20.7 bar) 0°F to 180°F (-18°C to 82°C)

Note: Air must be dry enough to avoid ice formation at temperatures below 32°F (2°C)  
 Sump Capacity .....0.4 Ounce (11 ml)  
 Weight ..... 0.6 lb. (0.27 kg)

### Materials of Construction

Body .....	316 Stainless Steel
Bowls .....	316 Stainless Steel
Drain .....	316 Stainless Steel
Element Holder .....	Acetal
Filter Element .....	Borosilicate Fiber
Seals .....	Fluorocarbon



# Compressed Air Filters

## Air Preparation Units - FF11 Coalescing Filter Standard 1/2" Ports

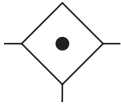

### Features

- Stainless steel construction handles most corrosive environments.
- Meets NACE specifications MR-01-75/ISO 15156.
- 1/8" female threaded drain\*.
- High Flow: 1/2" - 45 SCFM (77 Nm<sup>3</sup>/hr)<sup>§</sup>

\* Beginning January 2008

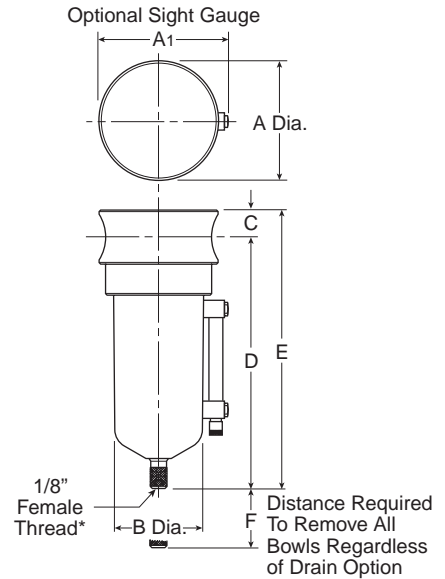

Port Size	NPT without sight gauge		NPT with sight gauge	
	Manual Twist Drain	Automatic Float Drain	Manual Twist Drain	Automatic Float Drain
1/2"	<b>Metal Bowl With Sight Gauge</b>			
	<b>F11-04DJSS</b>	<b>F11-04DJRSS</b>	<b>F11G04WJSS</b>	<b>F11G04WJRSS</b>

F11 Coalescing Filter Dimensions		
<b>A</b> 2.38 (60)	<b>A1</b> 2.50 (64)	<b>B</b> 1.75 (44)
<b>C</b> 0.56 (14)	<b>D</b> 5.00 (127)	<b>E</b> 5.56 (141)
<b>F</b> 2.12 (54)		

Standard part numbers shown bold. For other models refer to ordering information below.

<sup>§</sup> SCFM = Standard cubic feet per minute.  
Nm<sup>3</sup>/hr = Normal cubic meters per hour.

inches  
(mm)

### Ordering Information

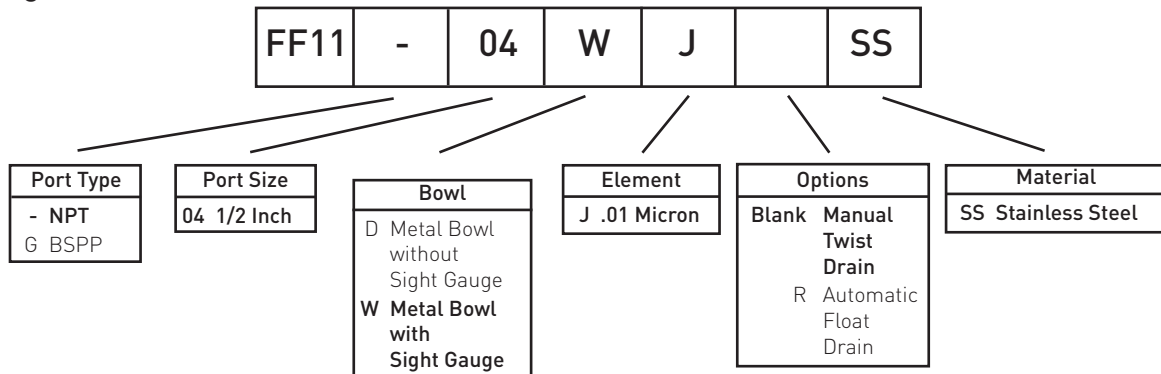

# Compressed Air Filters

## Air Preparation Units - FF11 Series Technical Information

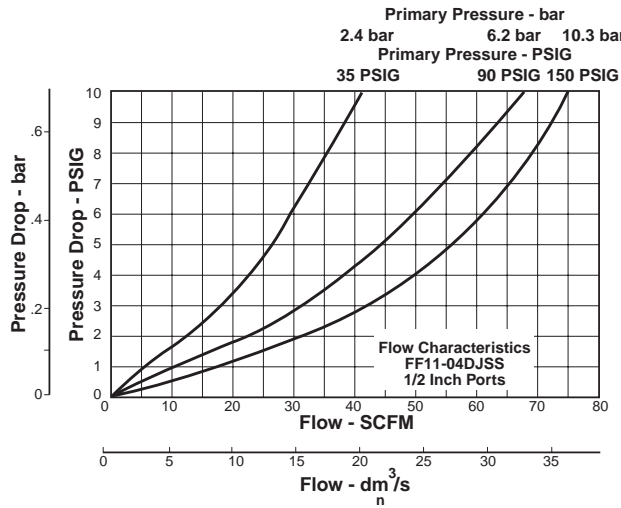

### F11 Filter Kits & Accessories

- Drain Kit -**
- Automatic Float Drain ..... SA602MDSS
  - Manual Twist Drain-
    - Small (Old) ..... SA600Y7-1SS
    - Large (New) ..... SAP05481
- Filter Element Kits -**
- 0.3 Micron ..... EKF71
- Pipe Nipple -**
- 1/2" 316 Stainless Steel ..... 616A28-SS

### Specifications

- Bowl Capacity ..... 4.0 Ounces
- Filter Rating ..... 0.01 Micron
- Sump Capacity ..... 1.7 Ounce
- Port Threads ..... 1/2 Inch
- Pressure & Temperature Ratings -**
  - Manual Twist Drain ..... 0 to 300 PSIG (0 to 20.7 bar)  
0°F to 180°F (-18°C to 82°C)
  - Manual Twist Drain (W) ..... 0 to 250 PSIG (0 to 17.2 bar)  
0°F to 150°F (-18°C to 66°C)
  - Automatic Float Drain ..... 0 to 175 PSIG (0 to 12 bar)  
40°F to 125°F (4°C to 52°C)

**Note:** Air must be dry enough to avoid ice formation at temperatures below 32°F (2°C).  
Weight ..... 1.9 lb. (0.85 kg)

### Materials of Construction

- Body ..... 316 Stainless Steel
- Bowls ..... 316 Stainless Steel
- Drain ..... 316 Stainless Steel

- Element Holder ..... Acetal
- Filter Element ..... Borosilicate Fiber
- Seals ..... Fluorocarbon
- Sight Gauge ..... Isoplast

### FF11 Media Specifications

Grade Designation	Coalescing Efficiency 0.3 to 0.6 Micron Particles	Maximum Oil Carryover <sup>1</sup> PPM w/w	Micron Rating	Pressure Drop PSID (bar) @ Rated Flow <sup>2</sup>		Flow: SCFM @3 PSID Operating Pressure 100 PSIG
				Media Dry	Media Wet With 10-20 wt. oil	
6	99.97%	0.008	0.01	1.0 (0.07)	2-3 (0.14-0.21)	??
10	95%	0.85	1.0	0.5 (0.03)	0.5 (0.03)	??

<sup>1</sup>Tested per ISO 12500-1 at 40 ppm inlet.  
<sup>2</sup>Add dry + wet for total pressure drop.

# Compressed Air Filters

## Air Preparation Units - FR364 Regulator -Miniature 1/4" Ports

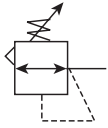

### Features

- Stainless steel construction handles most corrosive environments.
- Large diaphragm to valve area ratio for precise regulation and high flow capacity.
- Meets NACE specifications MR-01-75/ISO 15156.
- High Flow: 1/4" - 12 SCFM (20 Nm<sup>3</sup>/hr)<sup>§</sup>



R364

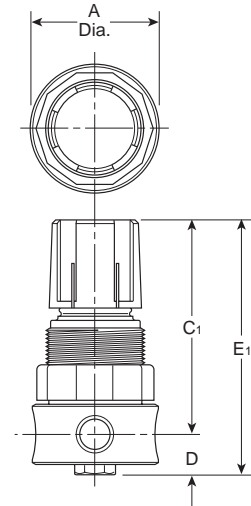

R364

Series	Adjustment Type	Port Size	NPT
FR364	Knob	1/4"	FR364-02CSS

<sup>§</sup> SCFM = Standard cubic feet per minute.  
Nm<sup>3</sup>/hr= Normal cubic meters per hour.

R364 Regulator Dimensions	
<b>A</b> 1.56 (40)	<b>C<sub>1</sub></b> 2.56 (65)
<b>D</b> 0.50 (13)	<b>E<sub>1</sub></b> 3.06 (78)

inches (mm)

NOTE: 1.25 Dia. (32mm) hole required for panel mounting.

### WARNING

Product rupture can cause serious injury.  
Do not connect regulator to bottled gas.  
Do not exceed maximum primary pressure rating.

### Ordering Information

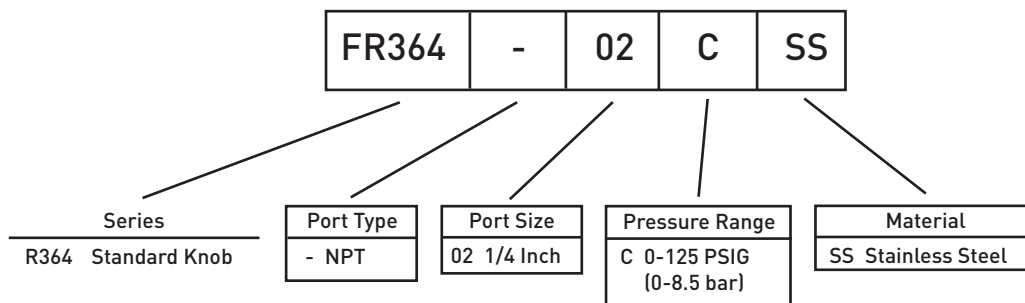

# Compressed Air Filters

## Air Preparation Units FR364 Air Line Regulators

### Technical Information

#### Operation

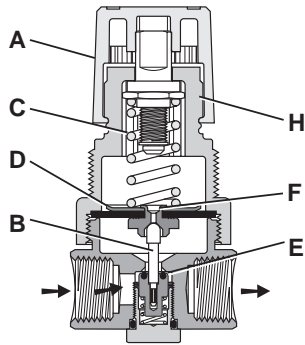

FR364

With the adjusting knob (A) turned fully counter-clockwise (no spring load), and pressure supplied to the regulator inlet port, the valve poppet assembly (B) is closed. Turning the adjusting knob clockwise applies a load to control spring (C). This load causes the diaphragm (D) and the valve poppet assembly (B) to move downward allowing flow across the seat area (E) created between the poppet assembly and the seat. Pressure in the downstream line is sensed below the diaphragm (D) and offsets the load of spring (C). As downstream pressure rises, poppet assembly (B) and diaphragm (D) move upward until the area (E) is closed and the load of the spring (C) and pressure under diaphragm (D) are in balance. A reduced outlet pressure has now been obtained, depending on spring load. Creating a demand downstream, such as opening a valve, results in a reduced pressure under the diaphragm (D). The load of control spring (C) now causes the poppet assembly to move downward opening seat area (E) allowing air to flow to meet the downstream demand. The flow of downstream air is metered by the amount of opening (E).

Should downstream pressure exceed the desired regulated pressure, the excess pressure will cause the diaphragm (D) to move upward against control spring (C), open vent hole (F), and vent the excess pressure to atmosphere through the hole in the bonnet (H). (This occurs in the relieving type regulator only.)

#### Technical Information

##### CAUTION:

##### REGULATOR PRESSURE ADJUSTMENT -

The working range of knob adjustment is designed to permit outlet pressures within their full range. Pressure adjustment beyond this range is also possible because the knob is not a limiting device. This is a common characteristic of most industrial regulators, and limiting devices may be obtained only by special design.

For best performance, regulated pressure should always be set by increasing the pressure up to the desired setting.

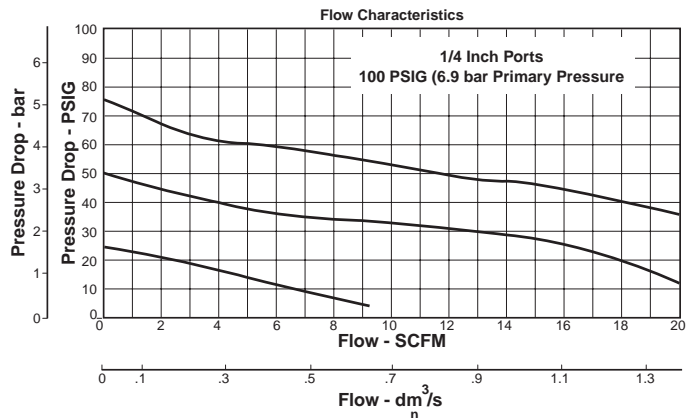

#### FR364 Regulator Kits & Accessories

R364 Bonnet Kit (Knob Included) .....	CKR364YSS
Gauge -	
160 PSIG (0 to 1100 kPa) .....	K4515N14160SS
Panel Mount Bracket (Stainless) .....	161X57-SS
Panel Mount Nut -	
Stainless .....	R05X51-SS
Plastic .....	R05X51-P
Service Kit -	
Relieving .....	RKR364YSS
Springs -	
0-125 PSIG Range .....	SPR-377-1-SS

#### Specifications

Gauge Port .....	1/4 Inch
Operation .....	Fluorocarbon Diaphragm
Port Threads .....	1/4 Inch
Pressure & Temperature Ratings - .....	300 PSIG Max (20.7 bar)
	40°F to 150°F [4°C to 66°C]
Weight .....	0.5 lb. (0.23 kg)

#### Materials of Construction

Adjustment Mechanism / Springs .....	316 Stainless Steel
Adjusting Knob (R364) .....	Polypropylene
Body .....	316 Stainless Steel
Bonnet (R364) .....	Acetal
Bottom Plug .....	316 Stainless Steel
Poppet .....	316 Stainless Steel
Seals .....	Fluorocarbon

# Compressed Air Filters

## Air Preparation Units - 05R Regulators - Economy 1/4", 3/8" NPT - Basic 1/4" Body

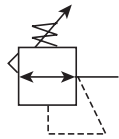

### Features

- Secondary aspiration plus balanced poppet provides quick response and accurate pressure regulation.
- Rolling diaphragm for extended life.
- Removable non-rising knob for panel mounting and tamper resistance.
- Easily serviced.
- Reverse Flow.
- High Flow: 1/4" - 30 SCFM [51 Nm<sup>3</sup>/hr]<sup>§</sup>  
3/8" - 40 SCFM [68 Nm<sup>3</sup>/hr]<sup>§</sup>

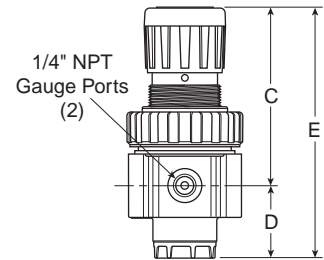
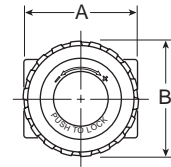

Port Size	NPT
Without Gauge	
1/4"	05R113A*
3/8"	05R213A*
With 160 PSI Gauge	
1/4"	05R118A*
3/8"	05R218A*

05R Regulator Dimensions		
A	B	C
2.00 (51)	2.06 (52)	3.16 (80)
D	E	
1.28 (32)	4.44 (113)	

Inches (mm)

NOTE: 1.53 Dia. (39mm) hole required for panel mounting.

<sup>§</sup> SCFM = Standard cubic feet per minute.  
Nm<sup>3</sup>/hr = Normal cubic meters per hour.

### Ordering Information



Port Size
1 1/4 Inch
2 3/8 Inch

Pressure Range
<u>Without Gauge</u> 13 125 PSIG/ 8.62 barg
<u>With Gauge**</u> 18 125 PSIG/ 8.62 barg

\*\* Includes 1-1/2" Dial Face Gauge

Relief
A Relieving

Engineering Level
* Will be Entered at Factory

Port Type
Blank NPT

\* 1/4 & 3/8 inch meet ISO 1179-1 Standard.

Options
Blank No Options

† Inlet Pressure is 100 PSIG. For other pressures, contact factory.

Preset / Pressure Limited
Blank None

# Compressed Air Filters

## Air Preparation Units 05R Air Line Regulators Technical Information

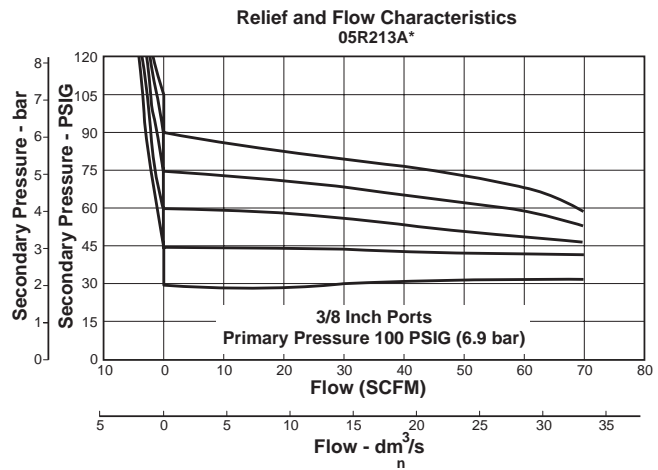
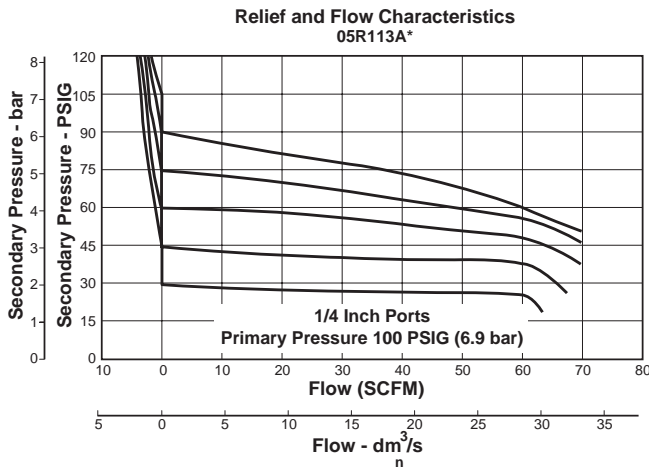

### CAUTION:

**REGULATOR PRESSURE ADJUSTMENT** – The working range of knob adjustment is designed to permit outlet pressures within their full range. Pressure adjustment beyond this range is also possible because the knob is not a limiting device. This is a common characteristic of most industrial regulators, and limiting devices may be obtained only by special design.

For best performance, regulated pressure should always be set by increasing the pressure up to the desired setting.

### WARNING

Product rupture can cause serious injury.  
Do not connect regulator to bottled gas.  
Do not exceed maximum primary pressure rating.

### 05R Regulator Kits & Accessories

Bonnet Assembly Kit .....	PS915P
Control Knob .....	P04420
Gauges – 1-1/2" Dial Face ????	
30 PSIG [0 to 2.1 bar] .....	K4515N14030
60 PSIG [0 to 4.1 bar] .....	K4515N14060
160 PSIG [0 to 11.0 bar] .....	K4515N14160
300 PSIG [0 to 20.0 bar] .....	K4515N14300
2" Dial Face	
60 PSIG [0 to 4.1 bar] .....	K4520N14060
160 PSIG [0 to 11.0 bar] .....	K4520N14160

Mounting Bracket Kit .....	PS963P
Panel Mount Nut – Metal .....	PS964P
Springs – 1-30 PSIG Range .....	P04427
1-60 PSIG Range .....	P04426
2-125 PSIG Range .....	P04425
2-200 PSIG .....	P02934
Service Kit – Relieving .....	PS908P

### Specifications

Gauge Ports (2) .....	1/4 Inch
Port Threads .....	1/4, 3/8 Inch
Primary Pressure Rating –	
Maximum Primary Pressure .....	250 PSIG (17.2 bar) Max.
For Secondary Pressure Ranges see above charts.	
Temperature Rating .....	32°F to 175°F (0°C to 80°C)
Low Temperature .....	-4°F to 125°F (-20°C to 52°C)
Weight .....	1.1 lb. (0.49 kg)

### Materials of Construction

Adjusting Stem .....	Brass
Bonnet .....	Plastic
Body .....	Zinc
Collar, Knob .....	Plastic
Diaphragm .....	Nitrile
Poppet & Cap .....	Plastic
Seals .....	Nitrile
Springs – Poppet & Control .....	Steel

# Compressed Air Filters

## Air Preparation Units - FR10 Regulator - Standard 1/2" Ports

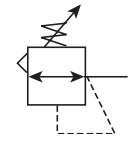

R10

### Features

- Stainless steel construction handles most corrosive environments.
- Large diaphragm to valve area ratio for precise regulation and high flow capacity.
- Meets NACE specifications MR-01-75/ISO 15156.
- Low temperature version available.
- High Flow: 1/2" – 80 SCFM (136 Nm<sup>3</sup>/hr)<sup>§</sup>

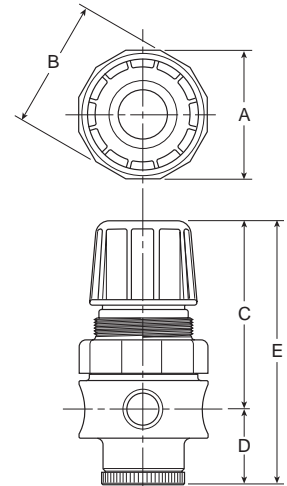

R10

Port Size	NPT
1/2"	FR10-04CSS

<sup>§</sup> SCFM = Standard cubic feet per minute.  
Nm<sup>3</sup>/hr = Normal cubic meters per hour.

R10, R11 Regulator Dimensions		
A	B	C
2.34 (60)	2.43 (62)	3.59 (91)
D	E	
1.38 (35)	4.97 (126)	

inches (mm)  
NOTE: 1.75 Dia. (44mm) hole required for panel mounting.

### WARNING

Product rupture can cause serious injury.  
Do not connect regulator to bottled gas.  
Do not exceed maximum primary pressure rating.

### Ordering Information

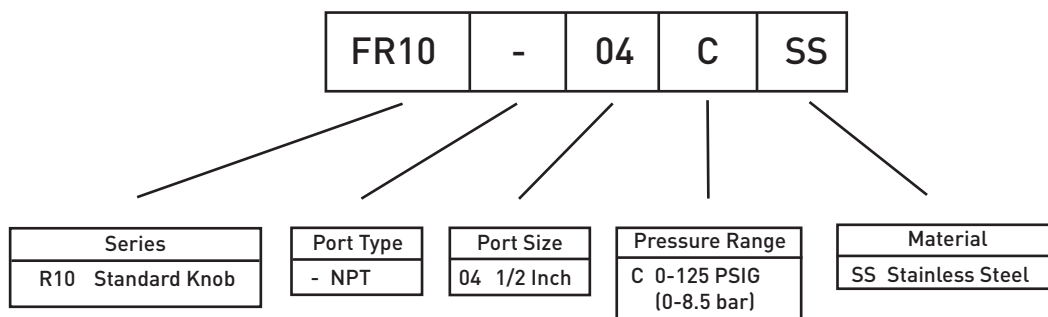

# Compressed Air Filters

## Air Preparation Units FR10 Air Line Regulators

### Technical Information

#### Operation

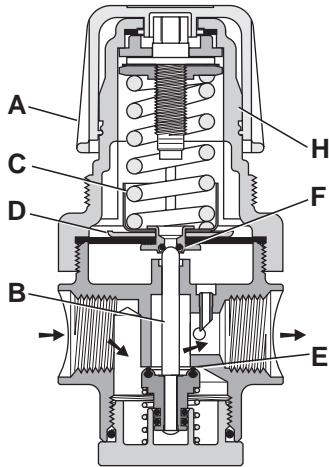

With the adjusting knob **(A)** turned fully counter-clockwise (no spring load), and pressure supplied to the regulator inlet port, the valve poppet assembly **(B)** is closed. Turning the adjusting knob clockwise applies a load to control spring **(C)**. This load causes the diaphragm **(D)** and the valve poppet assembly **(B)** to move downward allowing flow across the seat area **(E)** created between the poppet assembly and the seat. Pressure in the downstream line is sensed below the diaphragm **(D)** and offsets the load of spring **(C)**. As downstream pressure rises, poppet assembly **(B)** and diaphragm **(D)** move upward until the area **(E)** is closed and the load of the spring **(C)** and pressure under diaphragm **(D)** are in balance. A reduced outlet pressure has now been obtained, depending on spring load. Creating a demand downstream, such as opening a valve, results in a reduced pressure under the diaphragm **(D)**. The load of control spring **(C)** now causes the poppet assembly to move downward opening seat area **(E)** allowing air to flow to meet the downstream demand. The flow of downstream air is metered by the amount of opening **(E)**.

Should downstream pressure exceed the desired regulated pressure, the excess pressure will cause the diaphragm **(D)** to move upward against control spring **(C)**, open vent hole **(F)**, and vent the excess pressure to atmosphere through the hole in the bonnet **(H)**. (This occurs in the relieving type regulator only.)

#### Technical Information

##### CAUTION:

##### REGULATOR PRESSURE ADJUSTMENT -

The working range of knob adjustment is designed to permit outlet pressures within their full range. Pressure adjustment beyond this range is also possible because the knob is not a limiting device. This is a common characteristic of most industrial regulators, and limiting devices may be obtained only by special design.

For best performance, regulated pressure should always be set by increasing the pressure up to the desired setting.

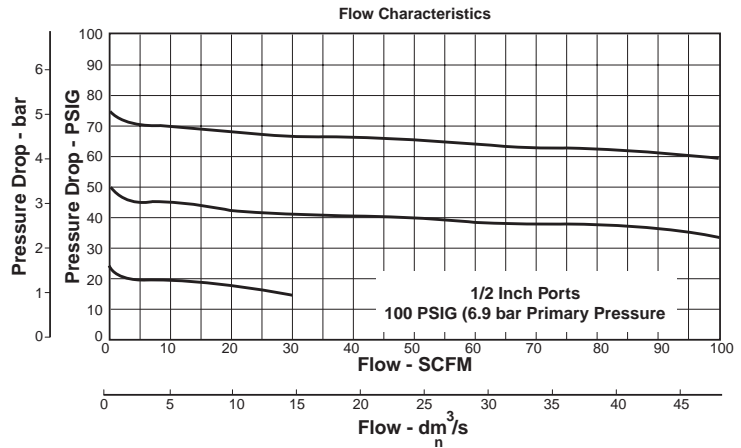

#### FR10 Regulator Kits & Accessories

R10 Bonnet Kit (Knob Included) .....	CKR10YSS
Gauge -	
160 PSIG (0 to 1100 kPa), 2" Face .....	K4520N14160SS
Panel Mount Bracket (Stainless) .....	161X57-SS
Panel Mount Nut -	
Stainless .....	R10X51-SS
Plastic .....	R10X51-P
Service Kit -	
Relieving .....	RKR10YSS
Springs -	
0-125 PSIG Range .....	SPR-389-1-SS

#### Specifications

Gauge Port .....	1/4 Inch
Operation .....	Fluorocarbon Diaphragm
Port Threads .....	1/2 Inch
Pressure & Temperature Ratings - .....	300 PSIG Max (20.7 bar)
	0°F to 150°F (-18°C to 66°C)

Note: Air must be dry enough to avoid ice formation at temperatures below 32°F (2°C).

Weight .....

#### Materials of Construction

Adjustment Mechanism / Springs .....	316 Stainless Steel
Body .....	316 Stainless Steel
Bonnet / Knob (R10) .....	Acetal
Bottom Plug .....	316 Stainless Steel
Poppet .....	316 Stainless Steel
Seals .....	Fluorocarbon



# Compressed Air Filters

## Air Preparation Units - 07R Regulators - Standard 3/8", 1/2", 3/4" NPT - Basic 1/2" Body

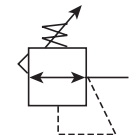

### Features

- Secondary aspiration plus balanced poppet provides quick response and accurate pressure regulation.
- Rolling diaphragm for extended life.
- Two high flow 1/4" gauge ports can be used as additional outlets.
- Easily serviced.
- Removable non-rising knob for panel mounting and tamper resistance.
- High Flow: 3/8" - 70 SCFM (119 Nm<sup>3</sup>/hr) §  
1/2" - 90 SCFM (153 Nm<sup>3</sup>/hr) §  
3/4" - 90 SCFM (153 Nm<sup>3</sup>/hr) §

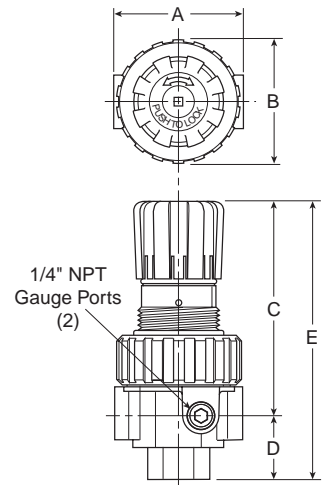

Port Size	NPT
Without Gauge	
3/8"	07R213A*
1/2"	07R313A*
3/4"	07R413A*

07R Regulator Dimensions		
A	B	C
3.24 (82)	2.74 (70)	4.79 (122)
D	E	
1.61 (41)	6.40 (163)	

Inches (mm)

NOTE: 2.00 Dia. (51mm) hole required for panel mounting.

§ SCFM = Standard cubic feet per minute.  
Nm<sup>3</sup>/hr = Normal cubic meters per hour.

**⚠ WARNING**

Product rupture can cause serious injury.  
Do not connect regulator to bottled gas.  
Do not exceed maximum primary pressure rating.

### Ordering Information

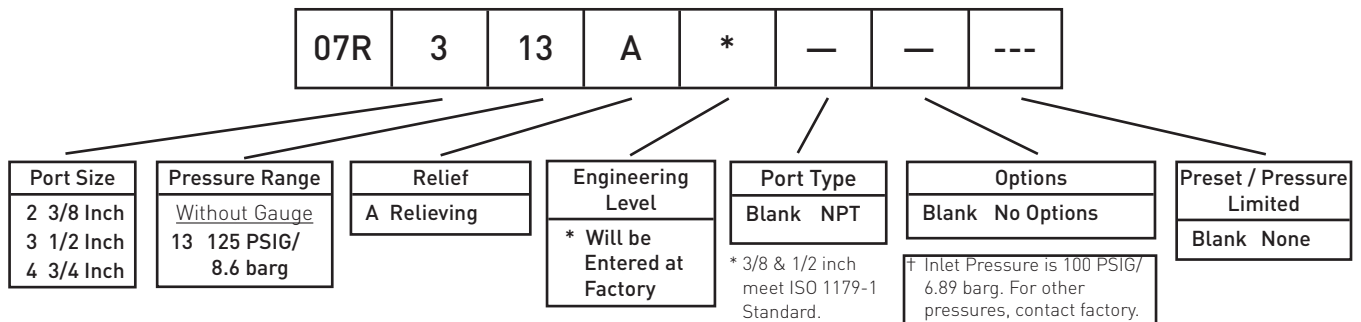

# Compressed Air Filters

## Air Preparation Units 07R Air Line Regulators Technical Information

Compressed Air Filters

Relief And Flow Characteristics  
07R213A\*

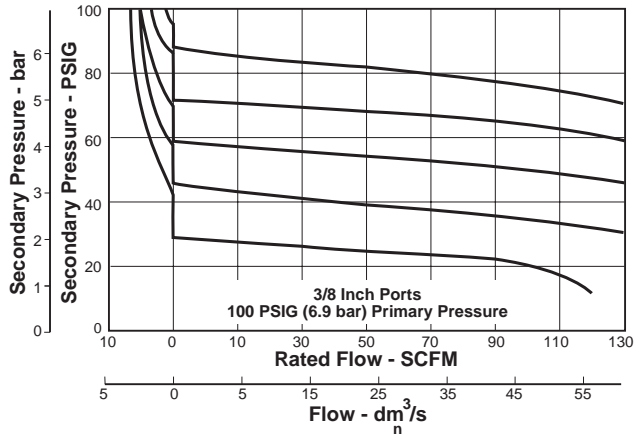

Relief And Flow Characteristics  
07R313A\*

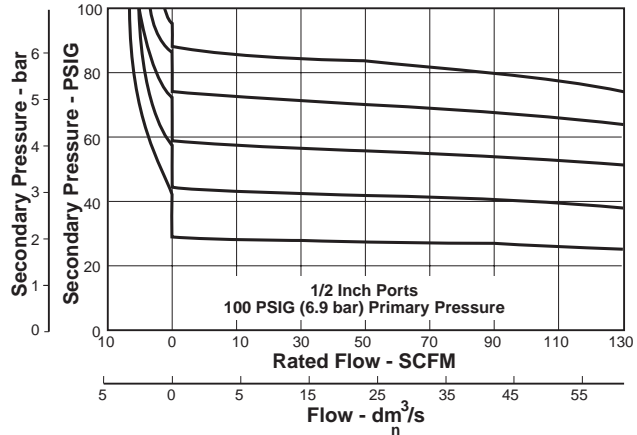

Relief And Flow Characteristics  
07R413A\*

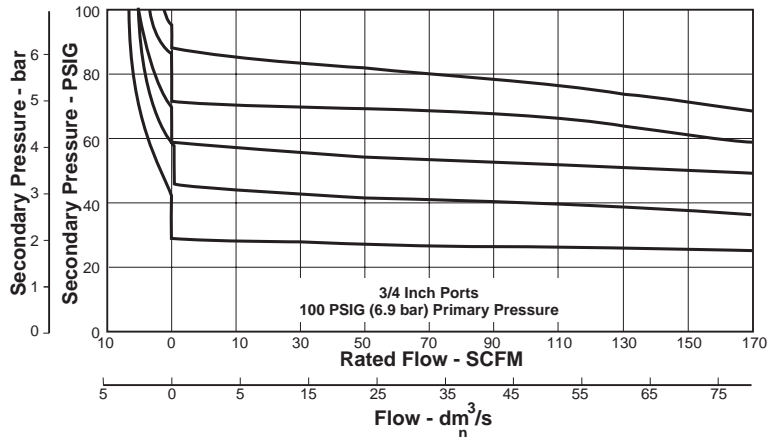

### CAUTION:

#### REGULATOR PRESSURE ADJUSTMENT -

The working range of knob adjustment is designed to permit outlet pressures within their full range. Pressure adjustment beyond this range is also possible because the knob is not a limiting device. This is a common characteristic of most industrial regulators, and limiting devices may be obtained only by special design.

For best performance, regulated pressure should always be set by increasing the pressure up to the desired setting.

### 07R Regulator Kits & Accessories

Bonnet Assembly Kit .....	PS715P
Control Knob .....	P04069B
Gauges - 60 PSIG (0 to 4.1 bar) .....	K4520N14060
160 PSIG (0 to 11.0 bar) .....	K4520N14160
Mounting Bracket Kit (Includes Panel Mount Nut) .....	PS807P
Panel Mount Nut - Plastic .....	P04082
Metal .....	P04079B
Service Kit - Relieving (Includes Poppet) .....	PS808P
Springs - 2-125 PSIG Range .....	P04063
Tamperproof Kit .....	PS737P

### Specifications

Gauge Ports (2) .....	1/4 Inch
(Can be used as additional High Flow 1/4 Inch Outlet Ports)	
Port Threads .....	3/8, 1/2, 3/4 Inch
Primary Pressure Rating -	
Maximum Primary Pressure .....	250 PSIG (17.2 bar)
Secondary Pressure Range -	
Standard Pressure .....	2 to 125 PSIG (0 to 8.6 bar)
Temperature Rating .....	32°F to 175°F (0°C to 80°C)
Weight 2.5 lb. (1.1 kg)	

### Materials of Construction

Adjusting Stem .....	Steel
Body .....	Zinc
Bonnet, Piston Stem, Valve Poppet & Cap .....	Plastic
Collar, Knob .....	Plastic
Diaphragm .....	Nitrile
Seals .....	Nitrile
Springs - Poppet .....	Stainless
Control .....	Steel

# Compressed Air Filters

## Air Preparation Units - P3NR Regulators - High Flow 3/4", 1", 1 1/2" NPT - Basic 1" Body

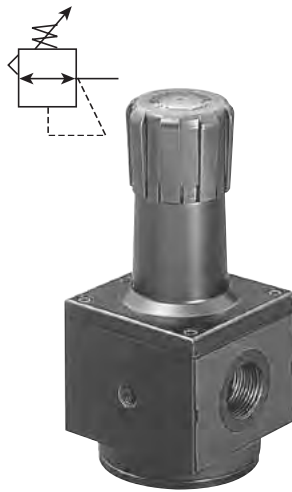

### Features

- Port blocks (PB) available to provide 1-1/2" port extension to 1" ported bodies.
- Self relieving feature plus balanced poppet provides quick response and accurate pressure regulation.
- Solid control piston for extended life.
- High Flow: 3/4" - 200 SCFM (340 Nm<sup>3</sup>/hr) §  
1" - 300 SCFM (510 Nm<sup>3</sup>/hr) §  
1 1/2" - 300 SCFM (510 Nm<sup>3</sup>/hr) §

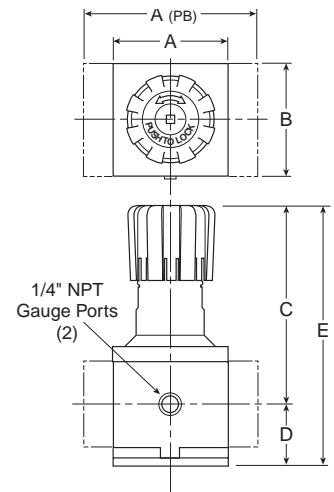

Port Size	NPT
Without Gauge	
3/4"	P3NRA96BNN
1"	P3NRA98BNN
1 1/2"	P3NRA9PBNN

P3NR Regulator Dimensions		
A	A <sup>(PB)</sup>	B
3.62 (92)	5.91 (150)	3.62 (92)
C	D	E
6.38 (162)	2.08 (53)	8.46 (215)

Inches (mm)

NOTE: 2.00 Dia. (51mm) hole required for panel mounting.

§ SCFM = Standard cubic feet per minute.  
Nm<sup>3</sup>/hr = Normal cubic meters per hour.

<b>WARNING</b>
Product rupture can cause serious injury. Do not connect regulator to bottled gas. Do not exceed maximum primary pressure rating.

### Ordering Information

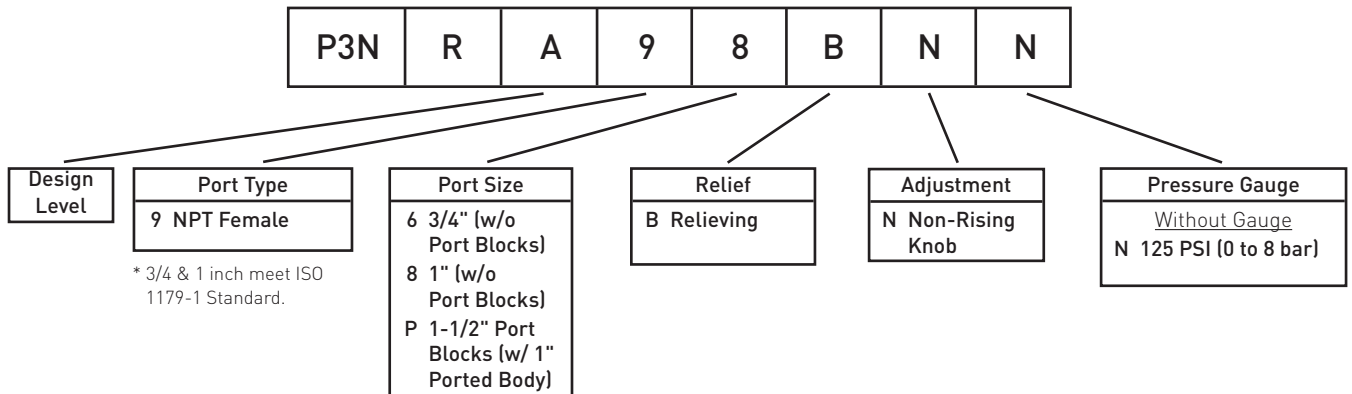

# Compressed Air Filters

## Air Preparation Units - P3NR Air Line Regulators

### Technical Information

Compressed Air Filters

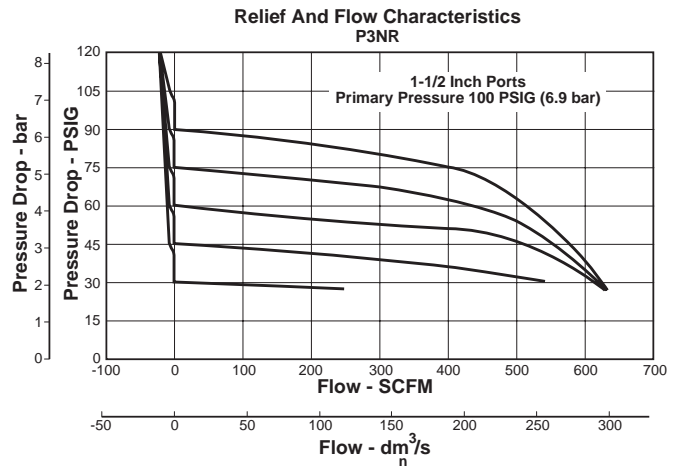
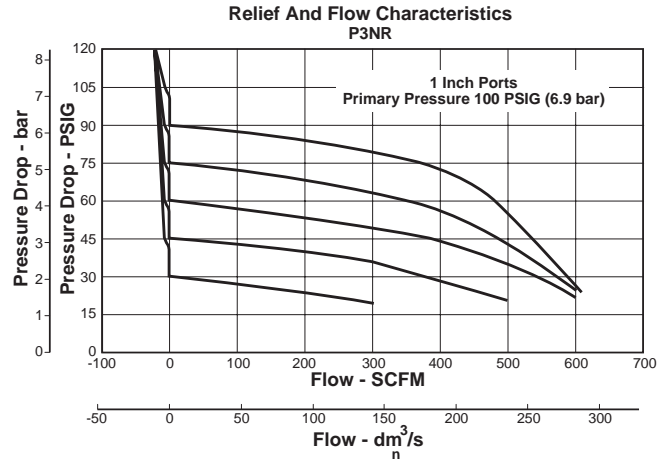
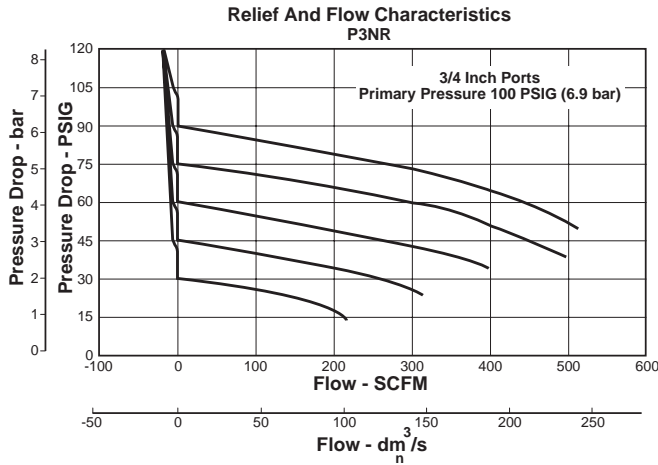

### CAUTION:

#### REGULATOR PRESSURE ADJUSTMENT –

The working range of knob adjustment is designed to permit outlet pressures within their full range. Pressure adjustment beyond this range is also possible because the knob is not a limiting device. This is a common characteristic of most industrial regulators, and limiting devices may be obtained only by special design.

For best performance, regulated pressure should always be set by increasing the pressure up to the desired setting.

### P3NR Regulator Kits & Accessories

- Control Knob P3NKA00PN
- Gauges – 60 PSIG (0 to 4.1 bar) ..... K4520N14060
- 160 PSIG (0 to 11.0 bar) ..... K4520N14160
- Mounting Bracket Kit\* ..... P3NKA00MW
- Service Kit – Relieving ..... P3NKA00RR
- Springs – 2-125 PSIG Range ..... C10A1308

### Specifications

- Gauge Ports (2) ..... 1/4 Inch  
(Can be used as additional High Flow 1/4 Inch Outlet Ports)
- Port Threads ..... 3/4, 1, 1-1/2 Inch
- Primary Pressure Rating –  
Maximum Primary Pressure ..... 250 PSIG (17.2 bar)
- Secondary Pressure Range –  
Standard Pressure ..... 2 to 125 PSIG (0 to 8.6 bar)
- Temperature Rating ..... 32°F to 175°F (0°C to 80°C)

- Weight – 3/4" ..... 4.2 lb. (1.9 kg)
- 1" ..... 4.2 lb. (1.9 kg)
- 1½" † ..... 5.3 lb. (2.4 kg)

### Materials of Construction

- Adjusting Stem ..... Steel
- Body ..... Aluminum
- Bonnet ..... Aluminum
- Knob ..... Plastic
- Piston ..... Plastic
- Poppet Assembly ..... Brass
- Seals ..... Nitrile
- Springs – Poppet & Control ..... Steel

† 1" Port Body with 1½" Port Block.



# Compressed Air Filters

## Air Preparation Units - 14E Filter/Regulator - Miniature 1/8", 1/4" NPT - Basic 1/8" Body

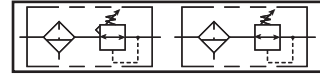

### Features

- Excellent water removal efficiency.
- Unbalanced poppet standard.
- Solid control piston for extended life.
- Space saving package offers both filter and regulator features in one integral unit.
- Non-rising adjustment knob.
- Two full flow 1/8" gauge ports.
- High Flow: 1/8" - 16 SCFM (27 Nm<sup>3</sup>/hr) §  
1/4" - 18 SCFM (31 Nm<sup>3</sup>/hr) §

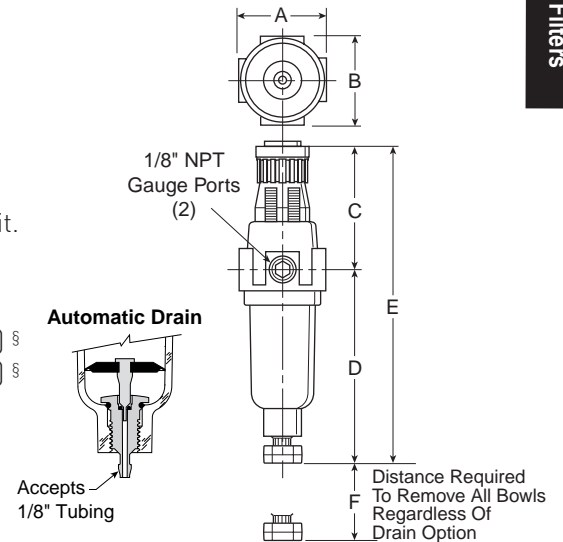

Port Size	NPT	
	Twist Drain	Automatic Pulse Drain
Poly Bowl <sup>‡</sup>		
1/8"	14E01B13F*	14E05B13F*
1/4"	14E11B13F*	14E15B13F*
Metal Bowl		
1/8"	14E03B13F*	14E07B13F*
1/4"	14E13B13F*	14E17B13F*

<sup>‡</sup> For polycarbonate bowl see Caution on page A2.

§ SCFM = Standard cubic feet per minute.  
Nm<sup>3</sup>/hr = Normal cubic meters per hour.

A	B	C
1.62 (41)	1.58 (40)	2.42 (61)
D	D <sup>†</sup>	E
3.79 (96)	3.64 (92)	6.21 (158)
E <sup>†</sup>	F	
6.06 (154)	1.60 (41)	

Inches (mm)  
<sup>†</sup> With Auto Drain

NOTE: 1.218 Dia. [31mm] hole required for panel mounting.

### Ordering Information

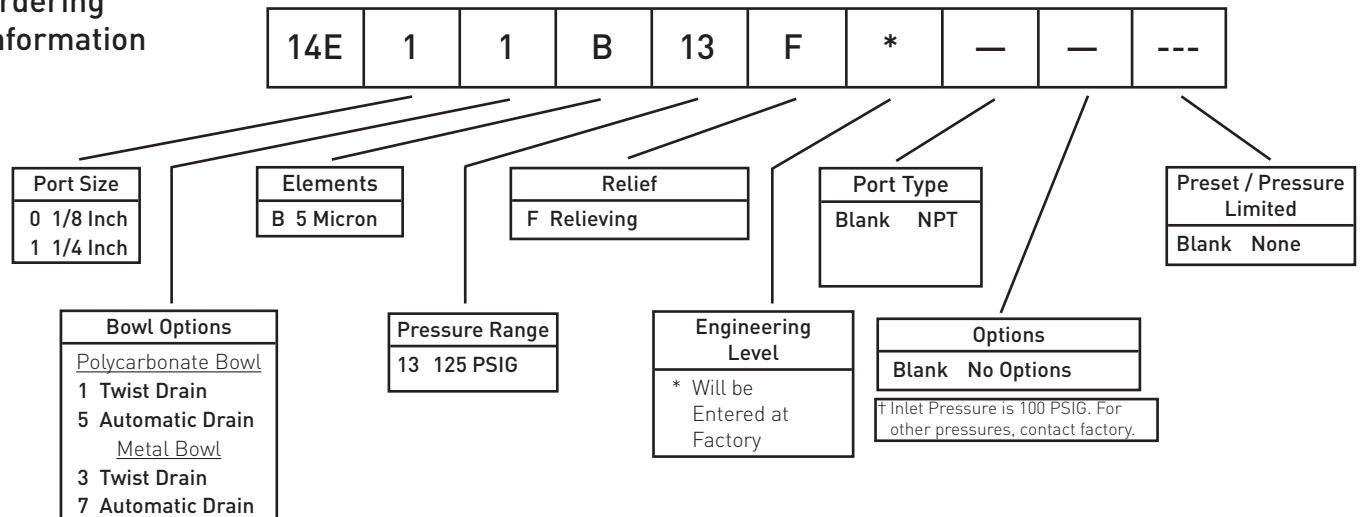

# Compressed Air Filters

## Air Preparation Units - Prep Air II, 14E Filter/Regulators Technical Information

Compressed Air Filters

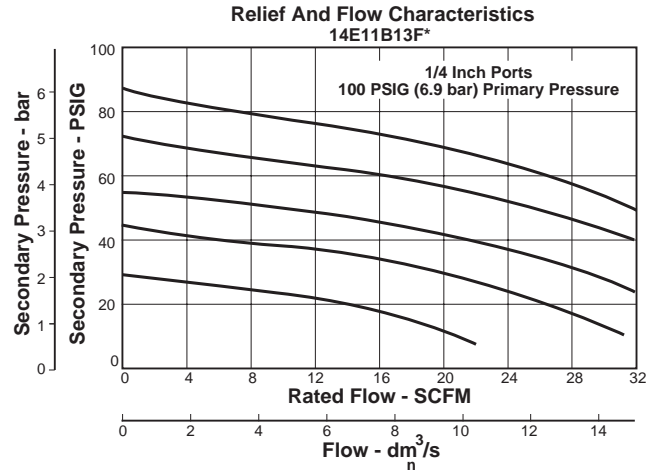
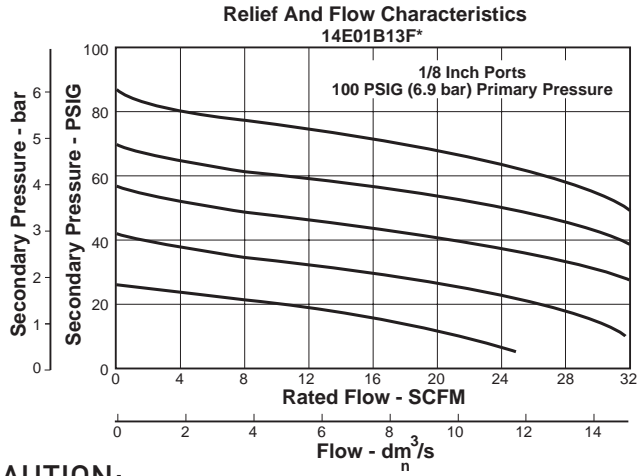

### CAUTION:

**REGULATOR PRESSURE ADJUSTMENT** – The working range of knob adjustment is designed to permit outlet pressures within their full range. Pressure adjustment beyond this range is also possible because the knob is not a limiting device. This is a common characteristic of most industrial regulators, and limiting devices may be obtained only by special design.

For best performance, regulated pressure should always be set by increasing the pressure up to the desired setting.

### 14E Filter / Regulator Kits & Accessories

<b>Bowl Kits –</b>	
Poly Bowl – Automatic Drain .....	PS408BP
Twist Drain.....	PS404P
Metal Bowl – Automatic Drain .....	PS451BP
Twist Drain.....	PS447BP
<b>Filter Element Kits – 5 Micron.....</b>	
	PS403P
<b>Gauges –????</b>	
30 PSIG (0 to 2.1 bar).....	K4515N18030
60 PSIG (0 to 4.1 bar).....	K4515N18060
160 PSIG (0 to 11.0 bar).....	K4515N18160
<b>Mounting Bracket Kit (Includes Panel Mount Nut) .....</b>	
	PS417BP
<b>Panel Mount Nut .....</b>	
	P78652
<b>Poppet Kit – Unbalanced.....</b>	
	PS424BP

<b>Service Kit – Relieving .....</b>	PS423P
<b>Springs – 2- 125 PSIG Range (Gold).....</b>	P01173

### Specifications

<b>Automatic Pulse Drain Tube Barb .....</b>	1/8 Inch
<b>Bowl Capacity .....</b>	1 Ounce
<b>Gauge Ports (2) (Can be used for Full Flow).....</b>	1/8 Inch
<b>Port Threads .....</b>	1/8, 1/4 Inch

### Pressure & Temperature Ratings –

- Polycarbonate Bowl
  - 0 to 150 PSIG (0 to 10.3 bar), 32°F to 125°F (0°C to 52°C)
- Metal Bowl
  - 0 to 250 PSIG (0 to 17.2 bar), 32°F to 175°F (0°C to 80°C)

**WARNING**

Product rupture can cause serious injury.  
Do not connect regulator to bottled gas.  
Do not exceed maximum primary pressure rating.

### Secondary Pressure Ranges –

Standard Pressure..... 2 to 125 PSIG (0 to 8.6 bar)

**Weight**..... 0.4 lb. (0.18 kg)

### Materials of Construction

<b>Adjusting Nut .....</b>	Brass
<b>Adjusting Stem &amp; Spring .....</b>	Steel
<b>Body .....</b>	Zinc
<b>Bonnet, Knob, Seat, Piston, Holder &amp; Deflector .....</b>	Plastic
<b>Bowls Available – Transparent .....</b>	Polycarbonate
<b>Metal (Without Sight Gauge) .....</b>	Zinc
<b>Drains – Manual – Twist Type</b>	
Body & Stem .....	Plastic
Seals.....	Nitrile
<b>Automatic – Pulse Type</b>	
Piston & Seals .....	Nitrile
Stem, Seat, Adaptor & Washers .....	Aluminum
<b>Filter Elements – 5 Micron (Standard).....</b>	
	Plastic
<b>Seals .....</b>	Nitrile

# Compressed Air Filters

## Air Preparation Units - FB548 Filter/Regulator - Miniature 1/4" Ports

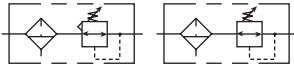

B548

### Features

- Stainless Steel Construction Handles Most Corrosive Environments
- Large Diaphragm To Valve Area Ratio For Precise Regulation And High Flow Capacity
- 1/8" Female Threaded Drain\*
- Meets NACE Specifications MR-01-75/ISO 15156.
- High Flow: 1/4" - 12 SCFM (20 Nm<sup>3</sup>/hr) §

\* Beginning January 2008

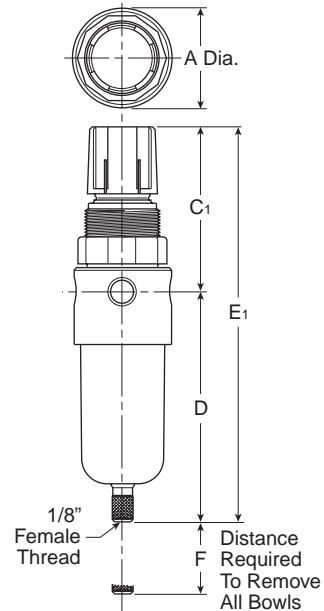

Port Size	NPT
1/4"	FB548-02DGCSS

FB548 Piggyback Dimensions		
A	C <sub>1</sub>	D
1.56 (40)	2.17 (55)	3.63 (92)
E <sub>1</sub>	F	
3.06 (78)	1.58 (40)	

§ SCFM = Standard cubic feet per minute.  
Nm<sup>3</sup>/hr = Normal cubic meters per hour.

inches (mm)  
NOTE: 1.25 Dia. (32mm) hole required for panel mounting.

	<b>WARNING</b>
<p>Product rupture can cause serious injury. Do not connect regulator to bottled gas. Do not exceed maximum primary pressure rating.</p>	

### Ordering Information

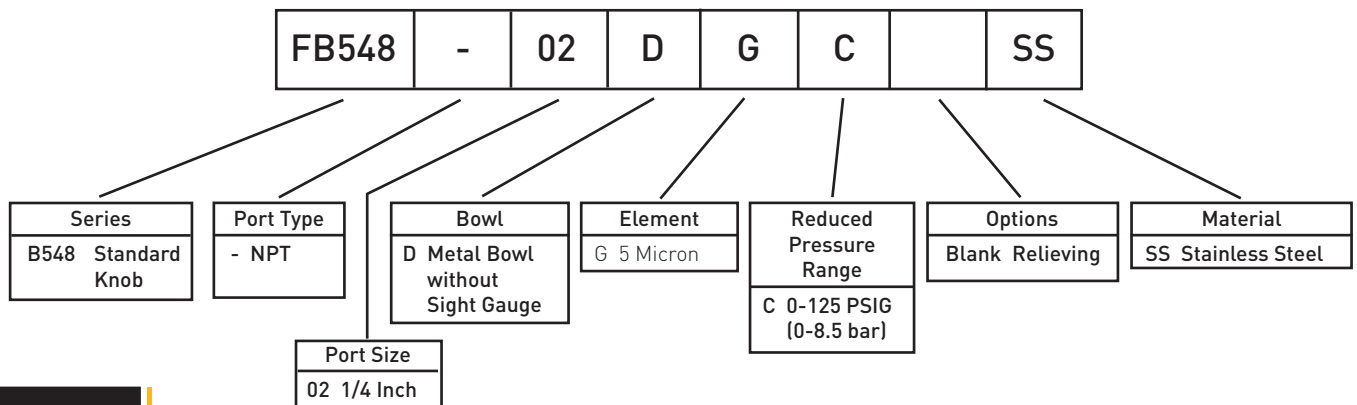

# Compressed Air Filters

## Air Preparation Units - FB548 Filter/Regulators Technical Information

Compressed Air Filters

### Operation

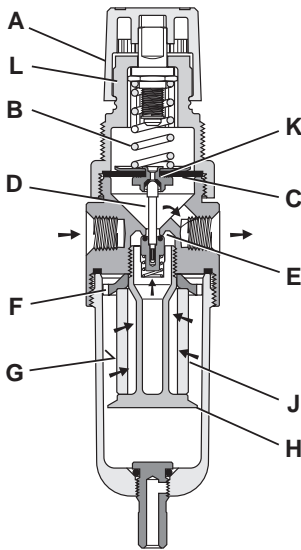

Turning the adjusting knob clockwise applies a load to control spring (B) which forces diaphragm (C) and valve poppet assembly (D) to move downward allowing filtered air to flow through the seat area (E) created between the poppet assembly and the seat. "First stage filtration". Air pressure supplied to the inlet port is directed through deflector plate (F) causing a swirling centrifugal action forcing liquids and coarse particles to the inner bowl wall (G) and down below the lower baffle (H) to the quiet zone. After liquids and large particles are removed in the first stage of filtration "second stage filtration" occurs as air flows through element (J) where smaller particles are filtered out and retained. The air flow now passes through seat area (E) to the outlet port of the unit. Pressure in the downstream line is sensed below the diaphragm (C) and offsets the load of spring (B). When downstream pressure reaches the set-point, poppet valve assembly (D) and diaphragm (C) move upward closing seat area (E). Should downstream pressure exceed the desired regulated pressure, the excess pressure will cause the diaphragm (C) to move upward opening vent hole (K) venting the excess pressure to atmosphere through the hole in the bonnet (L). (This occurs in the standard relieving type filter/regulators only.)

### Technical Information

#### CAUTION:

**REGULATOR PRESSURE ADJUSTMENT** – The working range of knob adjustment is designed to permit outlet pressures within their full range. Pressure adjustment beyond this range is also possible because the knob is not a limiting device. This is a common characteristic of most industrial regulators, and limiting devices may be obtained only by special design.

For best performance, regulated pressure should always be set by increasing the pressure up to the desired setting.

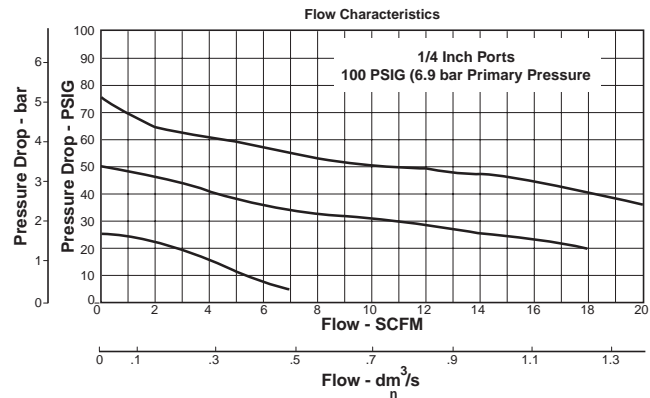

### FB548, Regulator Kits & Accessories

FB548 Bonnet Kit (Knob Included) .....	CKR364YSS
Filter Element Kits -	
Particulate (5 Micron).....	EK504VY
Gauge -	
160 PSIG (0 to 1100 kPa), 2" Face.....	K4515N14160SS
Manual Twist Drain .....	SA600Y7-1SS
Panel Mount Bracket (Stainless).....	161X57-SS
Panel Mount Nut -	
Stainless .....	R05X51-SS
Plastic .....	R05X51-P
Service Kit -	
Relieving .....	RK549YSS
Springs -	
0-125 PSIG Range .....	SPR-377-1-SS

### Specifications

Bowl Capacity .....	1.0 Ounces/28 ml
Filter Rating .....	5 Micron
Gauge Port .....	1/4 Inch
Operation .....	Fluorocarbon Diaphragm
Port Threads .....	1/4 Inch
Pressure & Temperature Ratings - .....	300 PSIG Max (20.7 bar) 0°F to 150°F (-18°C to 66°C)
Note: Air must be dry enough to avoid ice formation at temperatures below 32°F (2°C).	
Sump Capacity .....	0.4 Ounce (11 ml)
Weight .....	0.6 lb. (0.27 kg)

### Materials of Construction

Adjustment Mechanism / Springs .....	316 Stainless Steel
Body .....	316 Stainless Steel
Bonnet (B548) .....	Acetal
Bottom Plug .....	316 Stainless Steel
Knob (B548) .....	Polypropylene
Poppet .....	316 Stainless Steel
Seals .....	Fluorocarbon



# Compressed Air Filters

## Air Preparation Units - 06E Filter/Regulator - Compact 1/4", 3/8", 1/2" NPT - Basic 3/8" Body

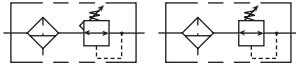

### Features

- Space saving package offers both filter and regulator features for optimal performance.
- Excellent water removal efficiency.
- Rolling diaphragm for extended life.
- Quick response, and accurate pressure regulation regardless of changing flow or inlet pressure.
- Two high flow 1/4" gauge ports can be used as additional outlets.
- Shown with recommended metal bowl guard.
- High Flow: 1/4" – 46 SCFM (78 Nm<sup>3</sup>/hr) §  
3/8" – 55 SCFM (93 Nm<sup>3</sup>/hr) §  
1/2" – 61 SCFM (104 Nm<sup>3</sup>/hr) §

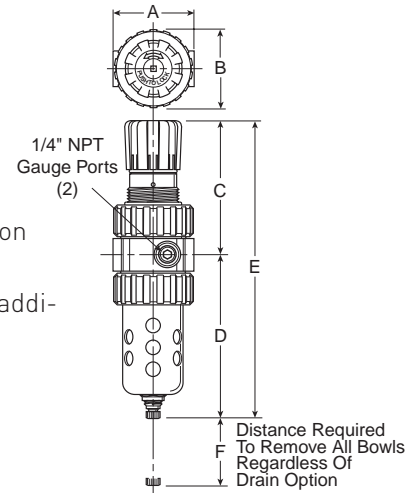

Port Size	NPT	
	Twist Drain	Automatic Float Drain
Poly Bowl <sup>‡</sup> / Metal Guard		
1/4"	06E12B13A*	06E16B13A*
3/8"	06E22B13A*	06E26B13A*
1/2"	06E32B13A*	06E36B13A*
Metal Bowl / Sight Gauge		
1/4"	06E14B13A*	06E18B13A*
3/8"	06E24B13A*	06E28B13A*
1/2"	06E34B13A*	06E38B13A*

06E Filter / Regulator Dimensions			
A	B	C	D
2.81 (71)	2.74 (70)	4.69 (119)	5.69 (145)
D <sup>†</sup>	E	E <sup>†</sup>	F
5.74 (146)	10.38 (264)	10.43 (265)	2.25 (57)

Inches (mm)  
<sup>†</sup> With Twist Drain or Auto Pulse Drain

<sup>‡</sup> For polycarbonate bowl see Caution on page 2.

<sup>§</sup> SCFM = Standard cubic feet per minute.  
 Nm<sup>3</sup>/hr = Normal cubic meters per hour.

NOTE: 2.00 Dia. (50.8 mm) hole required for panel mounting. Max. panel thickness 1/4".

**⚠ WARNING**

**Product rupture can cause serious injury.  
 Do not connect regulator to bottled gas.  
 Do not exceed maximum primary pressure rating.**

### Ordering Information

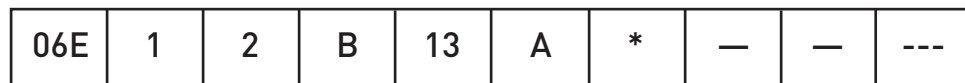

Port Size
1 1/4 Inch
2 3/8 Inch
3 1/2 Inch

Elements
B 5 Micron

Relief
A Relieving

Port Type
Blank NPT

\* 1/4 & 3/8 inch meet ISO 1179-1 Standard.

Preset
Blank None

Bowl Options	
Polycarbonate Bowl	Metal Bowl
2 Metal Bowl Guard / Twist Drain	4 Sight Gauge / Twist Drain
6 Metal Bowl Guard / Auto Float Drain	8 Sight Gauge / Auto Float Drain

Pressure Range
13 125 PSIG

Engineering Level
* Will be Entered at Factory

Options
Blank No Options

<sup>†</sup> Inlet Pressure is 100 PSIG. For other pressures, contact factory.

# Compressed Air Filters

## Air Preparation Units - 06E Filter/Regulators Technical Information

Compressed Air Filters

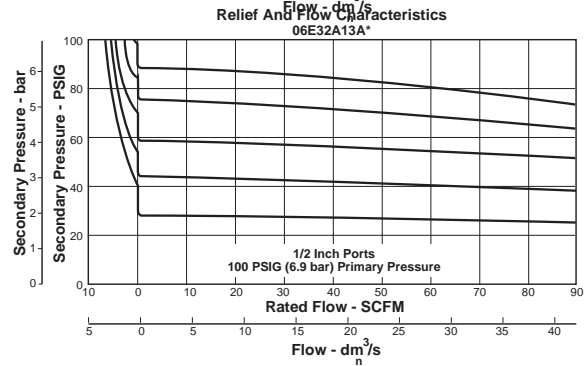
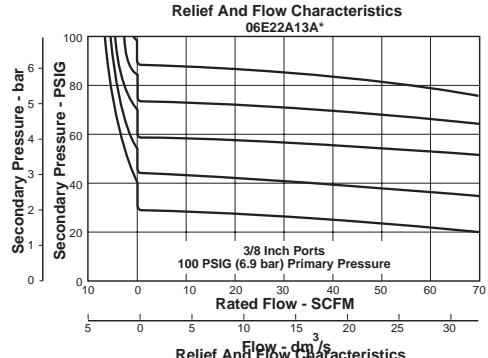
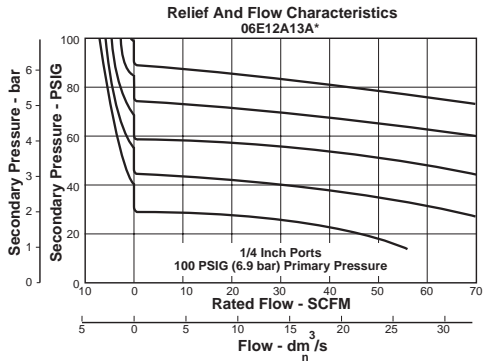

### CAUTION:

**REGULATOR PRESSURE ADJUSTMENT** – The working range of knob adjustment is designed to permit outlet pressures within their full range. Pressure adjustment beyond this range is also possible because the knob is not a limiting device. This is a common characteristic of most industrial regulators, and limiting devices may be obtained only by special design.

For best performance, regulated pressure should always be set by increasing the pressure up to the desired setting.

### 06E Filter / Regulator Kits & Accessories

Bonnet Assembly Kit.....	PS715P
Bowl Guard Kit .....	PS705P
Bowl Kits –	
Poly Bowl – Automatic Float Drain .....	PS722P
Twist Drain .....	PS732P
Metal Bowl – Sight Gauge / Automatic Drain .....	PS723P
Sight Gauge / Twist Drain .....	PS735P
Control Knob.....	P04069B
Drain Kit – Automatic Float Drain .....	PS506P
Twist Drain .....	PS512P
Filter Element Kits – 5 Micron.....	PS702
Gauges – 60 PSIG (0 to 4.1 bar).....	K4520N14060
160 PSIG (0 to 11.0 bar) .....	K4520N14160
Mounting Bracket Kit (Includes Panel Mount Nut).....	PS707P
Panel Mount Nut .....	P04082
Service Kits – Non-Relieving (Includes Poppet) .....	PS711P
Relieving (Includes Poppet).....	PS710P
Seat Insert Kit .....	PS713P
Spring – 2- 125 PSIG Range.....	P04063
Tamperproof Kit (Key Lock) .....	PS737P

### Specifications

Bowl Capacity .....	4.4 Ounces (125 ml)
Gauge Ports (2) .....	1/4 Inch (Can be used as Additional Full Flow 1/4" Outlet Ports)
Port Threads .....	1/4, 3/8, 1/2 Inch

### Pressure & Temperature Ratings –

Polycarbonate Bowl – 0 to 150 PSIG (0 to 10.4 bar)
32°F to 125°F (0°C to 52°C)
Metal Bowl – 0 to 250 PSIG (0 to 17.2 bar)
32°F to 175°F (0°C to 80°C)
Automatic Float Drain – 15 to 250 PSIG (1.0 to 17.2 bar)

### Secondary Pressure Range –

Standard Pressure.....	2 to 125 PSIG (0 to 8.6 bar)
------------------------	------------------------------

Sump Capacity.....	1.75 Ounces
Weight .....	1.6 lb. (0.7 kg)

### Materials of Construction

Adjusting Stem .....	Steel
Body .....	Zinc
Bonnet, Internal Parts .....	Plastic
Bowls Available – Transparent .....	Polycarbonate
Metal (With or Without Sight Gauge) .....	Zinc
Bowl Guard .....	Steel
Collar .....	Plastic
Diaphragm.....	Nitrile
Drains – Manual Twist Drain Standard	
Body & Nut .....	Plastic
Automatic Float Drain Optional (Interchangeable for Field Conversions)	
Operating Range.....	10 to 250 PSIG (.7 to 17.2 bar)
Housing, Float .....	Plastic
Seals .....	Nitrile
Springs, Push Rod.....	Stainless Steel
Knob .....	Plastic
Filter Elements – 5 Micron (Optional) .....	Plastic

Seals .....	Nitrile
Sight Gauge .....	Polyamide
Springs – Poppet .....	Stainless Steel
Control.....	Steel



# Compressed Air Filters

## Air Preparation Units - FB11 Filter/Regulator - Standard 1/2" Ports

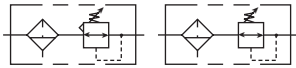

B11

### Features

- Stainless steel construction handles most corrosive environments.
- Large diaphragm to valve area ratio for precise regulation and high flow capacity.
- 1/8" female threaded drain.
- Meets NACE specifications MR-01-75/ISO-15156.
- Low temperature version available.
- High Flow: 1/2" - 72 SCFM (122 Nm<sup>3</sup>/hr) §

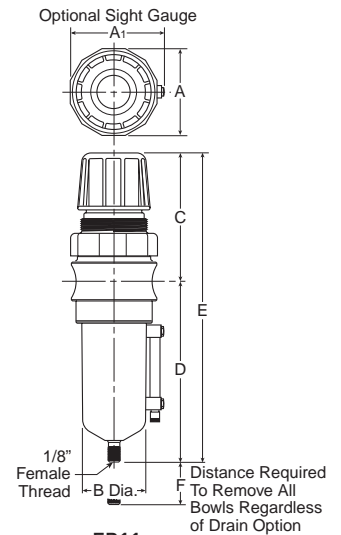

FB11

Port Size	Adjustment Type	NPT		BSPP	
		Manual Twist Drain	Automatic Float Drain	Manual Twist Drain	Automatic Float Drain
1/2"	Metal Bowl with Sight Gauge				
	Knob	<b>FB11-04WGCSS</b>	<b>FB11-04WGRSS</b>	FB11G04WGCSS	FB11G04WGRSS

FB11 Piggyback Dimensions		
<b>A</b> 2.34 (60)	<b>A1</b> 2.50 (64)	<b>B</b> 1.75 (44)
<b>C</b> 3.59 (91)	<b>D</b> 5.00 (127)	<b>E</b> 8.59 (218)
<b>F</b> 2.12 (54)		

Standard part numbers shown bold. For other models refer to ordering information below.

§ SCFM = Standard cubic feet per minute.  
Nm<sup>3</sup>/hr = Normal cubic meters per hour.

inches (mm)  
NOTE: 1.75 Dia. (44mm) hole required for panel mounting.

### ⚠ WARNING

Product rupture can cause serious injury.  
Do not connect regulator to bottled gas.  
Do not exceed maximum primary pressure rating.

### Ordering Information

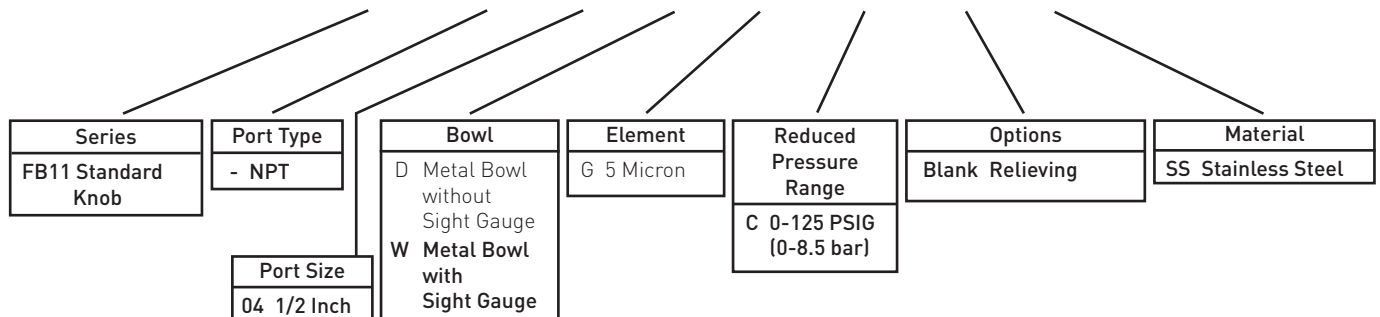
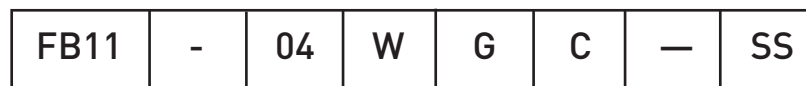

# Compressed Air Filters

## Air Preparation Units - FB11 Filter/Regulators

### Technical Information

#### Operation

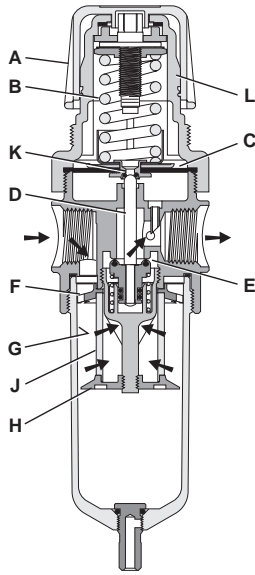

Turning the adjusting knob clockwise applies a load to control spring (B) which forces diaphragm (C) and valve poppet assembly (D) to move downward allowing filtered air to flow through the seat area (E) created between the poppet assembly and the seat. "First stage filtration".

Air pressure supplied to the inlet port is directed through deflector plate (F) causing a swirling centrifugal action forcing liquids and coarse particles to the inner bowl wall (G) and down below the lower baffle (H) to the quiet zone. After liquids and large particles are removed in the first stage of filtration "second stage filtration" occurs as air flows through element (J) where smaller particles are filtered out and retained. The air flow now passes through seat area (E) to the outlet port of the unit. Pressure in the downstream line is sensed below the diaphragm (C) and offsets the load of spring (B). When downstream pressure reaches the set-point, poppet valve assembly (D) and diaphragm (C) move upward closing seat area (E). Should downstream pressure exceed the desired regulated pressure, the excess pressure will cause the diaphragm (C) to move upward opening vent hole (K) venting the excess pressure to atmosphere through the hole in the bonnet (L). (This occurs in the standard relieving type filter/regulators only.)

#### Technical Information

##### CAUTION:

**REGULATOR PRESSURE ADJUSTMENT** - The working range of knob adjustment is designed to permit outlet pressures within their full range. Pressure adjustment beyond this range is also possible because the knob is not a limiting device. This is a common characteristic of most industrial regulators, and limiting devices may be obtained only by special design.

For best performance, regulated pressure should always be set by increasing the pressure up to the desired setting.

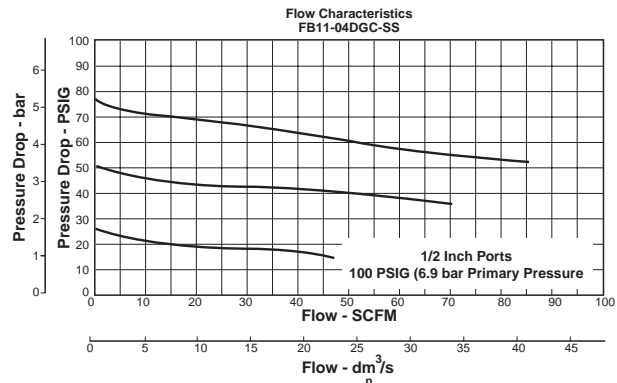

#### FB11 Regulator Kits & Accessories

FB11 Bonnet Kit (Knob Included) .....	CKR10YSS
Drain Kit -	
Automatic Float Drain .....	SA602MDSS
Manual Twist Drain .....	SA600Y7-1SS
Filter Element Kit -	
Particulate (5 Micron).....	EKF10VY
Gauge -	
160 PSIG (0 to 1100 kPa), 2" Face.....	K4520N14160SS
Panel Mount Bracket (Stainless).....	R10Y57-SS
Panel Mount Nut -	
Stainless .....	R10X51-SS
Plastic.....	R10X51-P
Service Kit -	
Relieving .....	RKR10YSS
Spring -	
0-125 PSIG Range .....	SPR-389-1-SS

#### Materials of Construction

Adjustment Mechanism / Springs .....	316 Stainless Steel
Body .....	316 Stainless Steel
Bonnet / Knob (B11) .....	Acetal
Bottom Plug .....	316 Stainless Steel
Poppet .....	316 Stainless Steel
Seals .....	Fluorocarbon
Sight Gauge .....	Isoplast

#### Specifications

Bowl Capacity .....	4.0 Ounces/114 ml
Filter Rating .....	5 Micron
Gauge Port .....	1/4 Inch
Operation .....	Fluorocarbon Diaphragm
Port Threads .....	1/2 Inch
Pressure & Temperature Ratings -	
Metal Bowl (D) .....	300 PSIG Max (20.7 bar) 0°F to 150°F (-18°C to 66°C)
Metal Bowl (W) .....	0 to 250 PSIG (0 to 17.2 bar) 0°F to 150°F (-18°C to 66°C)
Automatic Float Drain .....	15 to 175 PSIG (1 to 12 bar) 40°F to 125°F (4°C to 52°C)
Note: Air must be dry enough to avoid ice formation at temperatures below 32°F (2°C).	
Sump Capacity .....	1.7 Ounce
Weight .....	2.42 lb. (1.09 kg)

# Compressed Air Filters

## Automatic Drains - High and Normal Capacity

### High Capacity Electric Solenoid Drain

The Balston Automatic Drain Assembly, P/N 20-440 automatically removes water from Balston filter housings. The autodrain consists of a solenoid valve and an automatic timer that can be adjusted to the desired cycle time and is powered by 120 VAC. To drain receiving tanks, use any commercially available Y-strainer (ex. Keystone 911 Series or Watts Model 7771) to protect the 20-440.



20-440



20-211

### High Capacity Non-Electrical Float Drain

In the 20-211 design, a sealed stainless steel float operates a needle valve by means of a lever. All internal parts are stainless steel. The 20-211 drain is a rugged design for high volumes of liquid.

### Normal Capacity Non-Electrical Float Drain

In the 20-402 design, a float rises to operate a pilot-controlled valve when the liquid level in the body of the drain reaches a predetermined level. The float is reset by the force of line pressure as soon as the liquid is drained.



20-402

### Principal Specifications and Ordering Information

Model	20-211	20-440	20-402
Port Size	1/2" NPT	1/4" NPT	1/4" NPT
Maximum Pressure	440 psig (27.6 barg)	300 psig (20.7 barg)	200 psig (13.8 barg)
Minimum Pressure	10 psig (0.69 barg)	20 psig (1.4 barg)	40 psig (2.8 barg)
Maximum Temperature	500°F (260°C)	122°F (50°C)	130°F (54°C)
Shipping Weight	2 lbs. (0.9 kg)	2 lbs. (0.9 kg)	2 lbs. (0.9 kg)
Dimensions	2.5"W X 7.3"L (6cm X 19cm)	3"W X 4"L (7cm X 10cm)	3"W X 4L (7cm X 10cm)

# Compressed Air Filters

## Condensate Drains - Zero Air / Zero Energy Loss

### What is a zero air loss condensate drain?





Zero air loss condensate drains are designed for economical removal of unwanted water, oil emulsions, and other liquids. These drains will only open when liquid is present and will not allow any compressed air to escape from the system.

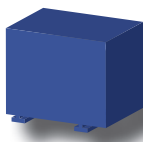

### Why are they needed?

- Condensate is always present in a compressed air system.
- If condensate is not removed from a compressed air system, it will adversely affect product quality and production efficiency and will eventually lead to costly downtime.

### Where are condensate drains used?

				
<b>Compressor with Aftercooler</b>	<b>Receiver Tank</b>	<b>Filter</b>	<b>Air Dryer</b>	<b>Drip Leg</b>
Removes the condensate that is collected after the air cools in the aftercooler	Removes the condensate that is collected when the air cools inside of the receiver tank	Removes the condensate that is collected in the filter bowl	Removes the condensate that is collected in the air dryer	Point-of-use applications: removes the condensate from compressed air pipes in a plant

### How does the Zero Air Loss Condensate drain compare to other drains?

Condensate Removal Method	Disadvantages of Other Drains	Advantages of ZLD
<b>Manual Drain</b> (operators must manually open valves to discharge condensate)	<ul style="list-style-type: none"> <li>• Requires constant attention</li> <li>• Always leads to excess air loss because air escapes when the valve is left open to drain the condensate</li> </ul>	<ul style="list-style-type: none"> <li>• Automatically drains condensate</li> <li>• When a minimum level of condensate is reached, the valve closes in time before compressed air can escape</li> </ul>
<b>Float Drain</b> (uses a float connected to a drain valve that opens when enough condensate is present and closes when condensate has been removed)	<ul style="list-style-type: none"> <li>• Float is susceptible to blockage from particulate contamination in condensate</li> <li>• Often sticks in open (leaks excess air) or closed position (no condensate is drained)</li> </ul>	<ul style="list-style-type: none"> <li>• Includes an integrated dirt screen between the level measurement and drain valve to protect the diaphragm valve</li> <li>• Particulate contamination is removed by the integrated dirt screen before fouling the moving parts</li> </ul>
<b>Solenoid Operated Drain Valves</b> (uses a timer which allows user to open and close valve at specified intervals)	<ul style="list-style-type: none"> <li>• The period for which the valve is open might not be long enough for adequate drainage of accumulated condensate</li> <li>• The valve will operate even if little or no condensate is present, resulting in air loss</li> <li>• Often requires a strainer to remove particulate contamination which can block the inlet and outlet ports</li> </ul>	<ul style="list-style-type: none"> <li>• Drain will remove condensate when liquid reaches the high level sensor</li> <li>• The drain will not operate until the liquid level reaches the high level sensor</li> <li>• Particulate contamination is removed by the integrated dirt screen before fouling the outlet port</li> </ul>

# Compressed Air Filters

## Condensate Drain - Zero Air / Zero Energy Loss

How does this drain work?

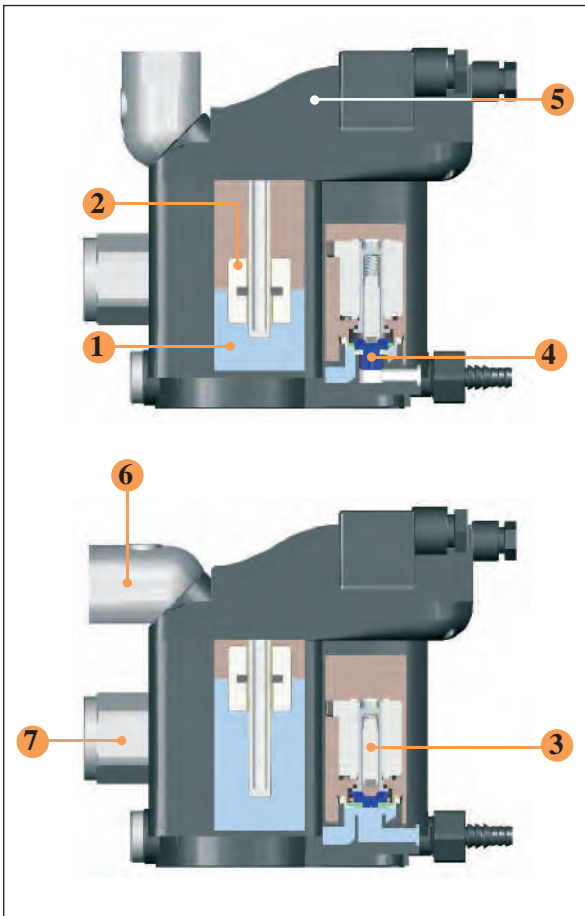

- 1 This collection vessel stores condensate until it is drained away.
- 2 This electronic level controller continuously monitors the liquid level inside the drain.
- 3 This depicts the electric drain valve. As soon as the electronic level controller detects a buildup of liquid, the valve opens and condensate is drained. When a minimum liquid level is reached, the valve closes before compressed air can escape.
- 4 The diaphragm valve ensures that contaminants are flushed out and that the condensate is prevented from forming an emulsion that would need expensive condensate treatment.
- 5 If an error has occurred (i.e. if the condensate cannot be discharged), the electronic control board (5) of the condensate drain generates an alarm signal. This allows timely detection of a problem and helps avoid excessive costs associated with condensate carryover to downstream components.
- 6 Unique swivel inlet connection for easy adaptability on 20-613 and 20-623. This allows the condensate line to be connected from the top or the rear. The 20-606 has a fixed inlet port with dynamic seal which allows the filter bowl to be removed while the drain is attached (not shown).
- 7 An additional liquid inlet on the 20-623 allows for the connection of a balance or vent line. This provides new connections so that condensate can no longer back up into the feed lines.

### The cost of compressed air when using a timed drain valve

**Annual Savings of a Zero Air Loss Drain**  
Versus Timed Solenoid Drain Valves

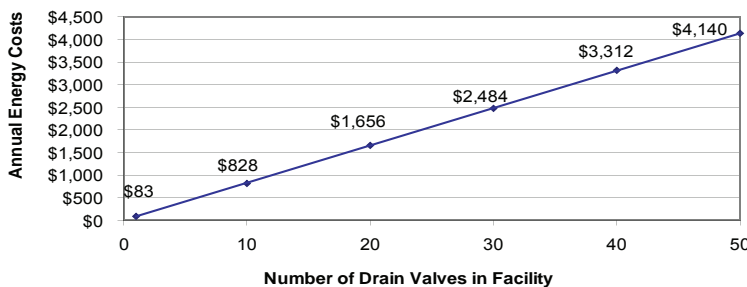

The annual cost of compressed air was calculated using data from the U.S. Department of Energy and several compressed air consultants. The average annual energy cost to maintain a compressed air system is \$0.23 per 1000 ft<sup>3</sup>. If a timed solenoid drain valve opens 3-4 times per hour, the cost of the wasted air will be \$80 per valve, per year.

**Zero Loss Drains don't waste any compressed air and have a payback of approximately 6 months - 1 year.**

**Easy  
installation &  
servicing!**

# Compressed Air Filters

## Condensate Drain - Zero Air / Zero Energy Loss

Compressed Air Filters

### Dimensions and Specifications



20-606

Dimensions (Inches/cm)

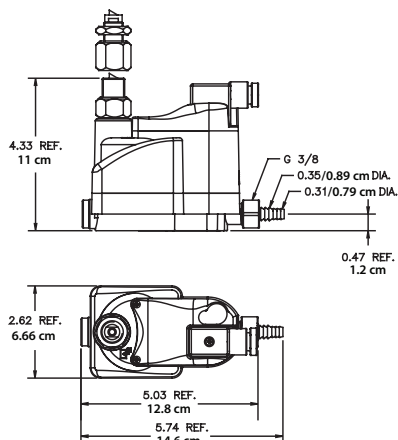

20-613

Dimensions (Inches/cm)

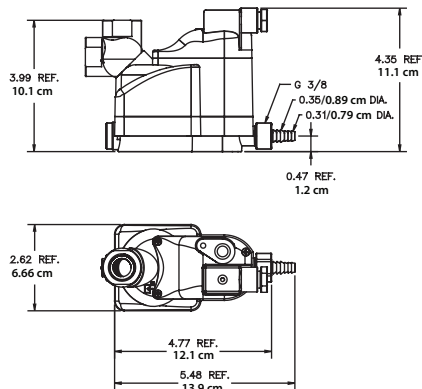

20-623

Dimensions (Inches/cm)

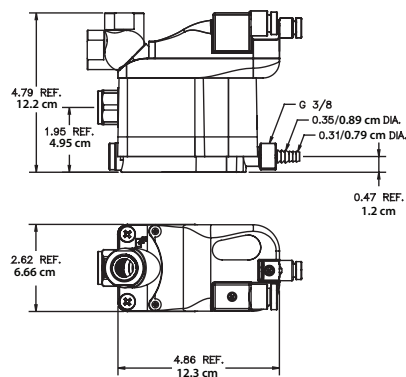

Model Number	Maximum Compressor Capacity	Maximum Refrigerated Dryer Capacity <sup>1</sup>	Maximum Filter Capacity <sup>2</sup>	Pressure Range	Temperature Range	Connection Size	Drain Capacity	Electrical Requirement
20-606	Not Recommended	Not Recommended	424 SCFM (720 m <sup>3</sup> /h)	3 - 232 PSIG (0.2 - 16 bar)	35 -140°F (2 - 60 °C)	3/8" NPT	6 Gallons/23 liters per day	120V <sub>AC</sub> (60Hz)
20-613	141 SCFM (240 m <sup>3</sup> /h)	283 SCFM (480 m <sup>3</sup> /h)	1413 SCFM (2,400 m <sup>3</sup> /h)	3 - 232 PSIG (0.2 - 16 bar)	35 -140°F (2 - 60 °C)	1/2" NPT	13 Gallons/49 liters per day	120V <sub>AC</sub> (60Hz)
20-623	247 SCFM (420 m <sup>3</sup> /h)	494 SCFM (840 m <sup>3</sup> /h)	2472 SCFM (4,200 m <sup>3</sup> /h)	3 - 232 PSIG (0.2 - 16 bar)	35 -140°F (2 - 60 °C)	1/2" NPT	23 Gallons/87 liters per day	120V <sub>AC</sub> (60Hz)

<sup>1</sup>Based on 100 psi (6.9 bar) working pressure, air compressor inlet at 77°F (25°C) at 60% RH, air discharge temperature of 95°F (35°C) following the aftercooler, pressure dewpoint of 37°F (2.8°C) after the refrigerated dryer.

<sup>2</sup>Condensate from aftercooler or refrigerated dryer to be drained upstream – only for residual oil content or small quantities of condensate.

Note: Drains are available with BSP threads; 24V/50 - 60Hz versions are available; 24V DC on request. A 6 ft. (2 m) line cord will be included with each drain.



# Compressed Air Filters

## Differential Pressure Indicator Kit

### Balston Differential Pressure Indicator

The Balston Differential Pressure Indicator (DPI) is used to monitor the pressure drop across the filters or other components in a compressed air system. The DPI is sensitive in the range of 0 to 5 psi differential.

### Principal Specifications & Ordering Information

Model	41-070	C02-2377
Differential Pressure Indicator	41-070	C02-2377
Indicator and Installation Kit (1)	41-071	N/A
Port Size	1/8" NPT	3/8"-24
Maximum Pressure	250 psig (17.2 barg)	250 psig (17.2 barg)
Maximum Temperature	130°F (54°C)	130°F (54°C)
Dimensions	1.7"W X 1.8"H (4cm X 5cm)	2.9"W X 2.25"H (7cm X 6cm)

#### Note

1 Installation kit includes fittings and tubing necessary for line-mounting the 41-070 DPI



41-070



41-070 Mounted on Filter  
Assembly



C02-2377

# Compressed Air Filters

## Miniature Disposable Filter Units Constructed of Nylon and PVDF

Compressed Air Filters

### Models 9922-05, 9933-05, 4433-05 and 9900-05

The 99XX-05 Models are the smallest Disposable Filter Units with 0.4 oz (11.7 ml) internal volume. These models are used in low flow gas or liquid sampling applications, such as liquids to specific-ion analyzers or gases to personal samplers. The Model 4433-05 has 1/4" and 3/8" barb connections molded into the inlet/outlet ports. The 9900-05 and 4433-05 are available with a color indicator that turns red when saturated with oil.

### Models 9922-11 and 9933-11

Models 9922-11 and 9933-11 are used for applications similar to the smaller DFUs (Models 9922-05 and 9933-05) which require greater solids holding capacity and can tolerate the increased retention time.

### Model 8833-11

These Disposable Filter Units are used as continuous coalescing filters with a third port serving as the drain, slip-stream, or by-pass port.



Model 99XX-05

Model 9922-05

Model 8833-11

### Retention Efficiency

Model	Efficiency for 0.01 Micron Particles and Droplets
DX, DQ	93%
BX, BK, BQ	99.99%

Table 1

Flow Rates Air Flow at 2 psi (0.14 bar) drop, standard cu. ft. (normal cubic meters) per min. SCFM (Nm<sup>3</sup>/hr) at indicated line pressure

Filter Housing Type	Volume of Housing (CU. FT.)	Filter Tube Grade	Flow Rate (CFM) At 10" Water Press. Drop., 0 PSIG (barg)	Flow Rate (SCFM) at indicated line pressure							
				2 psig (0.14 barg)	20 psig (1.4 barg)	40 psig (2.8 barg)	60 psig (4.1 barg)	80 psig (5.5 barg)	100 psig (6.9 barg)	125 psig (8.6 barg)	
9900-05	0.0004	DQ	0.2 (0.23)	1.2 (1.40)	2.5 (2.92)	3.9 (2.56)	5.4 (6.32)	6.8 (7.96)	8.3 (9.71)	10.1 (11.82)	
9922-05		BQ/BK (1)	0.1 (0.12)	0.8 (0.94)	1.6 (1.87)	2.6 (3.04)	3.5 (4.09)	4.5 (5.26)	5.4 (6.32)	6.6 (7.72)	
9933-05			DX	0.4 (0.47)	1.8 (2.11)	3.6 (4.21)	6 (7.02)	8 (9.36)	10 (11.70)	12 (14.04)	14.6 (17.08)
4433-05				BX	0.2 (0.23)	0.9 (1.05)	1.8 (2.11)	3 (3.51)	4 (4.68)	5 (5.85)	6 (7.02)

<sup>1</sup> BK = Red color indicator when saturated with oil.

### Installation Information

Compression fittings for 1/4" O.D. tubing may be obtained from the following manufacturers: Hoke, Inc. (Gyrolock); Crawford Fitting Co. (Swagelok); Parker-Hannifin Corp. (CPI); Legris, Inc. (push-on fittings); Jaco Mfg. Co. (plastic fittings).

The following brass fittings seal by O-ring compression and may be completely recovered and reused when changing filters. They may be purchased from Parker Hannifin Corp.

Connector 1/4" tubing to 1/4" NPT, female - P/N 11970

Connector 1/4" tubing to 1/4" tubing - P/N 11971

Elbow 1/4" tubing to 1/8" NPT female (for manual drain on Type 8833-11) - P/N 11972

#### For connections to low pressure plastic tubing

Tubing with 1/4" ID may be slipped over the DFU end fittings and held with tubing clamps. Parker Hannifin Corp. supplies plastic barbs to connect the DFU to smaller diameter plastic tubing. The connection is suitable for pressures to 50 psig.

DFU to 1/16" ID tubing P/N 14000 (bag of 20 barbs)

DFU to 1/8" ID tubing P/N 14001 (bag of 20 barbs)

Parker Hannifin Corp. also offers a manual drain valve for removal of coalesced liquids from the Type 8833-11-DX

Drain Valve 1/8" NPT (male) x 1/8" ID tubing (requires fitting part 11977) P/N 20120

# Compressed Air Filters

## Miniature Disposable Filter Units Constructed of Nylon and PVDF

### Principal Specifications

Model	9922-05	9900-05, 9933-05	4433-05	9922-11	9933-11	8833-11
Inlet and Outlet Ports	1/4" Tubing	1/4" Tubing	1st Tier/Barb 1/4" Tube 2nd Tier/Barb 3/8" Tube	1/4" Tubing	1/4" Tubing	1/4" Tubing
Drain	None	None	None	None	None	1/4" Tubing
Material of Construction	PVDF	Nylon	Nylon	PVDF	Nylon	Nylon
Filter Cartridge Length	1.25" (3.2 cm)	1.25" (3.2 cm)	1.25" (3.2 cm)	2.25" (5.7 cm)	2.25" (5.7 cm)	2 1/4"
Maximum Temperature	275°F (135°C) (1)	230°F (110°C) (1)	230°F (110°C) (1)	275°F (135°C) (1)	230°F (110°C) (1)	230°F (110°C) (1)
Maximum Pressure	125 psig/8.62 barg (2)	125 psig/8.62 barg (2)	125 psig/8.62 barg (2)	125 psig/8.62 barg (2)	125 psig/8.62 barg (2)	125 psig/8.62 barg (2)
Dimensions	1.0"D X 3.25"L (2.5 cm X 6 cm)	1.0"D X 3.25"L (2.5 cm X 6 cm)	1.0"D X 3.43"L (2.5 cm X 8.72 cm)	1.4"D X 4.6"L (9.1 cm X 12 cm)	1.4"D X 4.6"L (9.1 cm X 12 cm)	1.4"D X 4.6"L (9.1 cm X 12 cm)

### Ordering Information

For assistance, call toll-free at 1-800-343-4048 8AM to 5PM Eastern Time

Model	9922-05	9900-05	4433-05	9933-05	9922-11	9933-11	8833-11
Filter Cartridges Box of 10 Available in types Q and X	9922-05-□ (3)	9900-05-□ (3)	4433-05-□ (3)	9933-05-□ (3)	9922-11-□ (3)	9933-11-□ (3)	8833-11-□ (3)

#### Notes:

1 At 0 psig

2 At 110°F (43°C)

3 To designate the grade of filter tube in the DFU, insert Grade letters after DFU designation. For example, to obtain a grade BQ filter tube in a DFU 9922-05, order: 9922-05-BQ. Please note the following limitations:

DFU	Supplied With These Grades
4433-05, 9900-05, 9922-05, 9933-05	DQ, BQ, AQ (BK) (4)
9922-11, 9933-11	DX, BX, AQ
8822-11, 8833-11	DX, BX

4 BK Grade has a color indicating feature, which turns the cartridge red when saturated with oil. Available only in types 4433-05 and 9900-05.

## Application Notes

# Sample Filters

## Balston Sample Filters Protect Sensitive Analyzers

Balston Gas and Liquid Sample Analyzer Filters protect analyzers from sample impurities by removing solids and liquids from gases with 99.99999+% efficiency at 0.01 micron. Balston Sample Filters offer liquid filtration to 1 micron or lower. Composed of borosilicate glass microfibers with a resin binder, Balston sample filters are inert to most any gas or liquid.

To satisfy the extremely wide range of requirements for analyzer sample filters, Parker Hannifin Corporation supplies a complete line of filter housings in stainless steel, polypropylene, and other corrosion resistant materials, as well as a choice of high efficiency filter elements which are inert to most all liquids and gases.



## Product Features

- Remove liquids and solids from gas samples
- Remove solids and gas bubbles from liquid samples
- Coalesce and separate two liquid phases
- Filter solids and liquids from gases with 99.99999+% efficiency at 0.01  $\mu\text{m}$
- Temperature resistance to 900°F (482°C)
- Low pressure drop
- Long life between filter element changes

Emissions Monitoring  
and Analysis

Process Instrumentation  
and Controls

Slip Stream and By-Pass  
Sampling Filtration

Specialty Gas  
and Chemical Filtration



# Sample Filters

## Sample Filter Functions

### Coalescing Filtration: Separating Liquids From Gases

Microfibre Filter Cartridges efficiently separate suspended liquids from gases. The micro fibers capture the fine liquid droplets suspended in the gas and cause the droplets to run together to form large drops within the depth of the filter cartridge. The large drops, forced by the gas, flow to the downstream surface of the filter cartridge, from which the liquid drains by gravity. This process is called “coalescing”. Since the coalesced liquid drains from the cartridge at the same rate that liquid droplets enter the cartridge, the cartridge has an unlimited life when coalescing liquids from relatively clean gases, and the filters operate at their initial retention efficiency even when wet with liquid (see Figure 1). Note that the flow direction is inside-to-outside, to permit the liquid to drip from the outside of the filter to the housing drain.

Since the coalesced liquid drips from the downstream surface of the filter cartridge in the presence of filtered gas, it is important to avoid carryover, or entrainment, of liquid droplets by the gas leaving the filter housing. The possibility of entraining coalesced liquid is minimized by using an X-Type filter cartridge. The X-Type filter cartridges are constructed of two layers, an inner high-efficiency coalescing layer and an outer layer of coarse glass fibers. The coarse, rapidly-draining outer layer ensures that the liquid drips continuously from the bottom of the filter cartridge and minimizes the chance of liquid carryover. (The small internal volume of some filter housings does not permit use of the thick-wall X-Type cartridges, and therefore Q-Type cartridges must be used.) Re-entrainment of coalesced liquid is also avoided by ensuring that the gas flow rate through the housing is safely below the maximum shown in the flow charts on page 40. For most requirements for removing liquid from gas samples, Grade DX or DQ filter cartridges should be used.

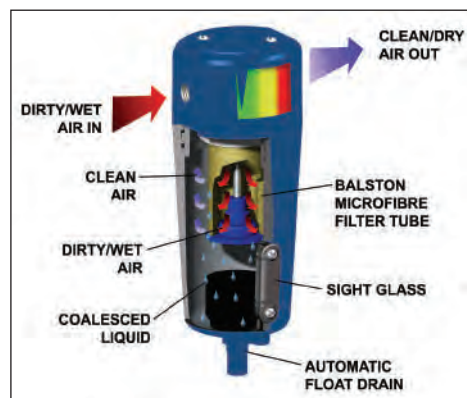

Figure 1  
Balston Compressed Air Filter

### Draining Collected Liquid

If liquid is carried into the filter in slugs rather than dispersed as droplets in the gas, a filter which is properly sized for steady-state conditions can be flooded and permit liquid carryover. If slugging of liquid is expected, a filter with a relatively large bowl should be selected to provide adequate liquid holding capacity and provisions should be made to drain the liquid automatically from the bowl of the housing as fast as it accumulates. An automatic float drain can be used if the pressure is in the 10-400 psig (0.69-28 barg) range. Above 400 psig (28 barg), the possibilities are: a constant bleed drain, a valve with automatic timed actuator (supplied by customer), or an external reservoir with manual valves (see Figure 2). The external reservoir can be constructed of pipe or tubing with sufficient volume to hold all the liquid which is expected to be collected during any period of unattended operation.

If the filter is under vacuum, the external reservoir is a practical method of collecting coalesced liquid for manual draining from time to time. If an external vacuum source, such as an aspirator, is available, the liquid may be drained continuously from the housing drain port.

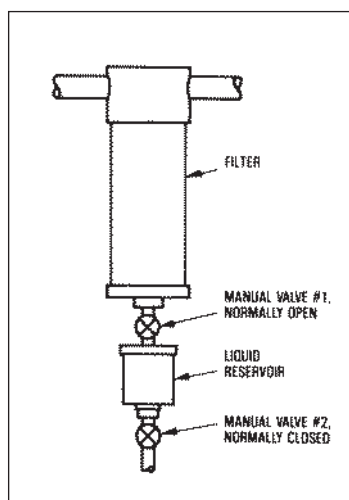

Figure 2  
To drain liquid while filter is operating at pressure or vacuum conditions, close valve #1, and open valve #2

# Sample Filters

## Sample Filter Functions

### Coalescing Filtration: Separating Two Liquid Phases

In principle, Microfibre Filter Cartridges separate suspended droplets of a liquid which is immiscible in another liquid by the same process as they separate droplets of liquid from a gas. The liquid droplets suspended in the continuous liquid phase are trapped on the fibers and run together to form large drops, which are then forced through the filter to the downstream surface. The large drops separate from the continuous liquid phase by gravity difference, settling if heavier than the continuous phase and rising if lighter. The coalescing action of Balston® filters is effective with aqueous droplets suspended in oil or other hydrocarbons, and also with oil in water suspensions.

In practice, liquid-liquid separations are much more difficult than liquid-gas separations. The specific gravity difference between two liquids is always less than between a liquid and a gas, and therefore a longer phase separation time is needed. Either the filter housing must be oversized or the flow rate greatly reduced to avoid carryover of the coalesced phase. As a rule of thumb, flow rate for liquid-liquid separation should be no more than one-fifth the flow rate for solid-liquid separation shown in the chart on page 77. Even at low flow rates, if the specific gravity difference between the two liquids is less than 0.1 units (for example, if an oil suspended in water has a specific gravity between 0.9 and 1.1), the separation time for the coalesced phase may be impractically long. In that case, if there is only a small quantity of suspended liquid, the filter tube can be used until saturated with the suspended liquid and then changed.

Another practical problem with liquid-liquid separations is that small quantities of impurities can act as surface-active agents and interfere with the coalescing action. For that reason it is not possible to predict accurately the performance of a liquid-liquid coalescing filter, and each system must be tested on site. The general guidelines for the system to start testing are to use Grade DX filter cartridges, and flow inside-to-outside at very low flow rates. If the suspended liquid is lighter than the continuous phase, the housing should be oriented so that the drain port is up. In general, Microfibre Filter Cartridges should be used for liquid-liquid coalescing in slipstream sampling applications only.

### Membrane Separation of Sample Streams

A Coalescer Membrane Combination Filter is designed to remove entrained liquid and particulate in gas samples for a wide variety of applications, and to prevent contamination or damage to the analyzers and sample system components. Microscopic pores contained within the membrane permit molecules of gas or vapor to flow through easily, allowing the composition of the sample gas to remain unchanged. However, even the smallest liquid molecules remain trapped and are unable to flow through the membrane's small passages under normal operating conditions. This is due to the high surface tension which causes liquid molecules to bind tightly together to form a group of molecules, moving together, which is too large to fit through the pores of the membrane.

The membrane is extremely inert, and is recommended for most process liquid applications, with the exception of hydrofluoric acid. It is also recommended for use in systems designed for PPB, PPM, and "percent level" component concentrations, as a result of its very low absorption characteristics. The membrane is strong and durable, but also very soft and pliable. Typically located upstream from the analyzer or component it is protecting, the Coalescer Membrane Combination provides protection even if other sample system components fail.

### Removing Gas Bubbles from Liquids

Microfibre Filter Cartridges readily remove suspended gas bubbles from liquid, eliminating the need for deaeration tanks, baffles, or other separation devices. Flow direction through the filter is outside-to-inside. The separated gas bubbles rise to the top of the housing and are vented through the drain port. If slipstream sampling is used, the separated bubbles are swept out of the housing with the bypassed liquid. Grade DX or Grade DQ is a good choice for gas bubble separation.

# Sample Filters

## Sample Filter Functions

### Quantitative Measurement of Solids in Gas

Quantitative determination of solids in gas, often a requirement in stack gas or other exhaust gas sampling, is readily accomplished using a Balston® Model 30 filter housing. In the Model 30 housing, the filter cartridge is sealed in place by a stainless steel spring acting on a lightweight stainless retainer disc (Figure 3). The retainer disc is pressed firmly into the end of the filter cartridge. When the housing is disassembled, the filter cartridge and retainer disc may be easily removed as a unit. At the beginning of the run, a tare weight is obtained on the filter cartridge-retainer disc assembly. When the filter is in service, flow through the filter cartridge is inside-to-outside so that even large solid particles which fall off the filter cartridge are held in the cartridge-disc assembly. At the conclusion of the run with a known volume of gas, the cartridge-disc assembly is reweighed, and the increase in weight can be expressed as solids concentration in the gas. Grade DH Filter Cartridges are recommended for high temperature sampling (up to 900°F/482°C). If the sampling or oven-drying temperatures do not exceed 300°F (149°C), Grade DQ may be used.

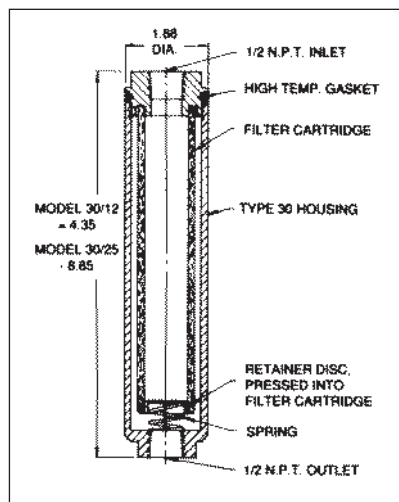

Figure 3

Filter cartridge and retainer disc of Model 30 housing may be weighed as a unit for quantitative determination of solids in gases.

### Slipstream or Bypass Sampling

Instrument sample use rates are invariably quite low, yet it is essential to minimize lag time in the sample system. Since analyzers often are located some distance from the sampling point, samples are usually transported to the analyzer at a relatively high flow rate to minimize lag time. The sample is divided at the analyzer, with the analyzer using the portion it requires (usually a very small fraction of the total sample), and the balance recycled to the process, or vented.

If the sample filter is located in the low-flow line to the analyzer, it will have good life between filter element changes because the solids loading rate is very low; however, the filter must be carefully selected to avoid introducing unacceptable lag time. If the filter is located in the high-flow portion of the sample system, its effect on sample lag time can be relatively low, but the life between filter changes may be inconveniently short because the element is filtering a much greater volume of material than the analyzer is using.

Ideally, a filter should be located at the point where the low-flow stream is withdrawn to the analyzer (Figure 4). This arrangement permits the main volume of the filter to be swept continuously by the high flow rate stream, thus minimizing lag time; at the same time, only the low-flow stream to the analyzer is filtered, thus maximizing filter life.

A slipstream filter requires inlet and outlet ports at opposite ends of the filter element to allow the high flow rate of the by-passed material to sweep the surface of the filter element and the filter reservoir, and a third port connected to the low flow rate line to the analyzer, which allows filtered samples to be withdrawn from the filter reservoir.

The Model 95 housings, 31GCFL, 41GCFL, 48S6, 49S6, DFU 8822-11, and DFU 8833-11 are ideal designs for slipstream sampling, since the inlet and the bypass ports are located at opposite ends of the housing, and the bypass port is as large as the inlet port. Larger housings, such as the Model 33S6, Model 45S6, and Model 27/35, can also be used for slipstream sampling, but the relatively small size of the drain port may limit the slipstream rate in some applications.

If bubble removal from a liquid is a requirement, this function may be combined with slipstream filtration, since the recommended flow direction for bubble removal is outside-to-inside, and the separated bubbles will be swept out of the housing by the bypass stream. In this case, the liquid feed should enter at the bottom of the housing and the bypass liquid exit at the top of the housing.



# Sample Filters

## Sample Filter Functions

### Slipstream Sampling Plus Coalescing Filtration

A special problem arises in slipstream sampling if the filter is to coalesce and continuously drain suspended liquid from a gas stream or to coalesce liquid droplets from a liquid stream. As noted earlier (see page 32), the coalesced liquid is removed in the form of large drops from the downstream side of the filter. Therefore, the coalescing filter requires two outlet ports, one for the dry gas and one for the liquid drain. To combine coalescing and slipstream filtration, a filter housing would need four ports - two for inlet and bypass and two for filtered gas and coalesced liquid - which is not a practical design. Therefore, slipstreaming plus coalescing requires two stages of filtration (Figure 5). The second (coalescing) stage must be located in the sample line to the analyzer, and should be as small as possible to minimize lag time. If the quantity of suspended liquid is not large, an in-line Disposable Filter Unit (9933-05 or 9922-05) may be considered as a trap for the suspended liquid, to be replaced when saturated.

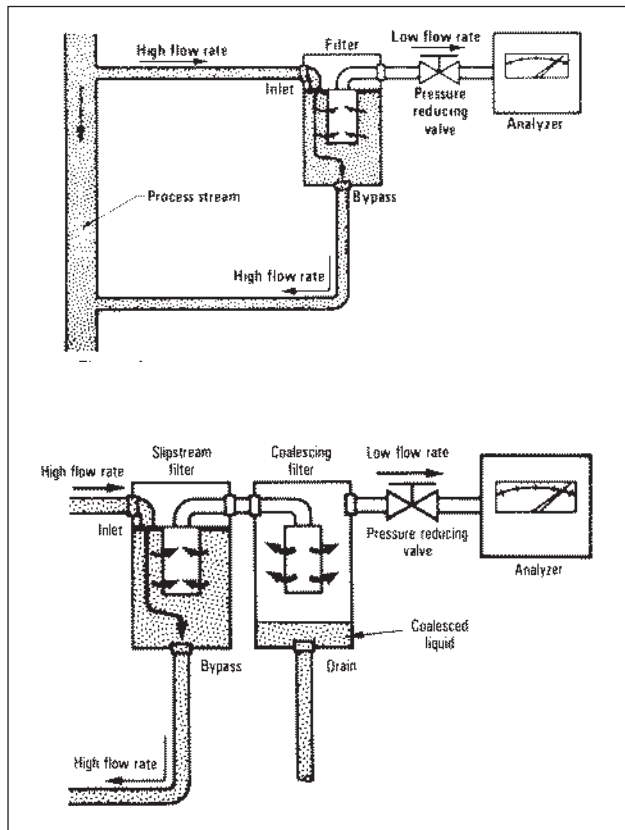

### Quantitative Measurement of Liquids in Gas

Quantitative determination of nonvolatile liquids suspended in a gas may be accomplished by a procedure similar to the solids determination (see page 68). In the case of liquids, the test is designed so that all the liquid entering the filter cartridge during the test period remains trapped on the fibers; i.e., the sample period is short enough that the filter cartridge does not become saturated and begin to drain liquid.

Any convenient filter housing may be used. The filter cartridge should be Grade BQ, to assure quantitative retention of aerosols, no matter what droplet size. With a known gas flow rate and test duration, the increase in weight of the filter cartridge will be a measure of the weight concentration of aerosol in the gas.

Considerable care must be taken to obtain a representative sample of aerosol in gas. If sampling from a large line, the sample probe should enter the pipe from above and if possible, extend into the pipe to avoid picking up liquid clinging to the wall of the pipe. There should be no valves, reducers, or sharp elbows in the sample line upstream from the filter.

**Figure 4**  
Slipstream or  
bypass filtration

**Figure 5**  
Slipstream Filtration  
plus coalescing  
filtration

# Sample Filters

## Application Recommendations

### Acid Plant Stack Gas

A frequently encountered sampling requirement is to analyze the gas composition in the exhaust from absorbers or scrubbers in acid manufacturing plants. The exhaust gas invariably contains droplets of dilute acid, which must be removed from the sample before it enters the analyzer. The recommendations are similar to those for natural gas sample filtration: Grade DQ or DX filter tube, inside-to-outside flow, and two stages of filtration if slipstream sampling is required. Depending upon the composition of the suspended liquid, housings may be stainless steel, PTFE (Model 95T), Monel (Model 95M), or PVDF (DFU 8822-11).

### Sampling Ambient Air or Other Atmospheric Pressure Gas

The filtration requirement for ambient air samplers is usually to remove solid particles or liquid droplets which could deposit on analyzer optical surfaces or cause other calibration problems. Grade DX or DQ filter cartridges are recommended. For low flow rate personal samplers, the compact and lightweight DFU 9933-05-DQ is often used. For higher flow rates, the Model 90 filter holder with Grade DX or DQ filters is recommended.

Ambient air sampling systems are often under negative pressure, induced by the sampling pump. If it is necessary to drain coalesced liquid from the system, the external reservoir is often the most convenient method (see Figure 2 on page 66).

### Sampling Water

Most water analyzers are well protected against the damage or calibration drift caused by solid contamination if a 10 micron (LP Grade 30) filter cartridge is used. If long filter life is desired in a system with high solids loading (including most tap water, well water, and cooling water), a two stage LP cartridge system is recommended: LP Grade 10 followed by LP Grade 30.

### Sampling Liquid Effluent Streams

Liquid effluent analyzers usually deal with aqueous streams having a high solids content. In addition, the analyzers are often located in remote areas of the plant and are infrequently serviced. Therefore, the sample filter system must have long life between filter cartridge changes, even in a high solids situation. The general recommendation for this requirement is a two stage filter system, LP Grade 10 filter cartridge followed by LP Grade 30 filter cartridge. The filters should be oversized as much as possible without causing excessive lag time. Plastic filter housings are usually a good choice.

Measurements of steam and condensate conductivity, specific ion concentrations, and feedwater additive concentrations are often required in high pressure boiler systems. In a continuous sampling system, the high pressure steam or condensate is cooled to below 100°F (38°C) and then the pressure is reduced to near atmospheric pressure for metering to the analyzers. Filtration is required upstream from the pressure reducing valves, to prevent pitting of the valve seats by suspended particles and to eliminate variations in flow rate to the analyzers.

A stainless steel filter housing with the appropriate pressure rating and Grade DX or DQ filter cartridge is recommended. Since the analyzer system is often located some distance from the sampling point, slipstream filtration is usually required. Figure 9 shows a sampling system in operation at a nuclear steam generating facility.

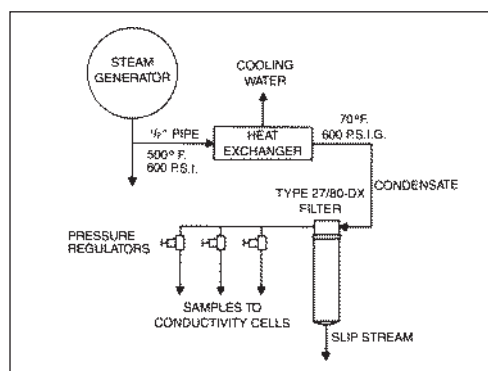

Figure 9

Model 27 filter with Grade DX filter cartridge protects pressure reducing valves in a steam condensate sampling system.

# Sample Filters

## Application Recommendations

### On-Line Process Analyzers

The variety of filtration requirements for on-line process analyzers precludes making general recommendations above for the required filtration functions. The filter housings most frequently used for process analyzer applications are the Model 95S6 and Model 91S6, which provide the corrosion resistance of Model 316 stainless steel (complies with NACE specification MR-01-75), a pressure rating of 5000 psig (345 barg), have full slipstream sampling capability, and minimum internal volume.



**Figure 6**  
Model 95S6, 316 stainless steel with 5,000 psig pressure rating, is the filter housing most frequently used in process analyzers

### Natural Gas Analyzers

To protect gas composition analyzers from liquids and solids, Grade DX or DQ filter tubes are recommended, with inside-out flow direction. If both slipstream sampling and coalescing are required, a two stage system must be used, as described on page 75.

The Model 85, 5000 psig (345 barg) rating and Model 37, 4000 psig (276 barg) rating housings comply with NACE specification MR-01-75. For lower pressure applications, any stainless steel housing of appropriate flow capacity may be used.

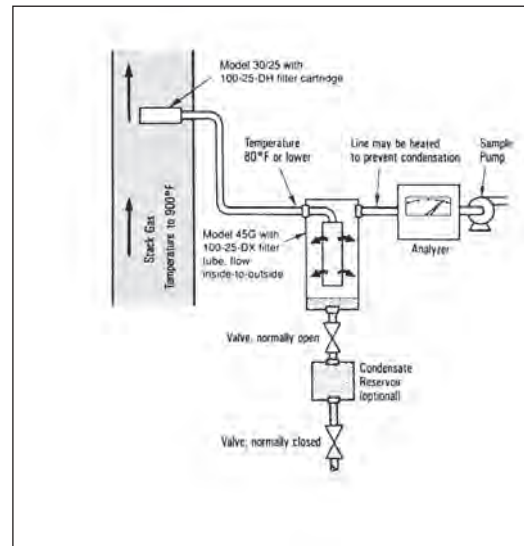

**Figure 7**  
Model 85 (left) or Model 37/12 (right) are used for natural gas sample filtration when a housing larger than the Model 95S6 is required

### Stack Gas Sampling

The Model 30 housing with Grade DH filter cartridge is used for quantitative determination of solids in stack gas, as described on page 68. The Model 30 may also be used as a beginning-of-the-line filter at stack gas temperature up to 900°F (95°C), to prevent solids from entering the gas sample line. Grade DH is used for this purpose. After the sample is cooled, a coalescing filter with Grade DX tube is used to remove suspended liquids before the sample goes to the analyzer. Flow direction is inside-to-outside. Model 33G or 45G housings are often used in this application to permit a visual check on the liquid level in the filter housing. Since there often is a considerable amount of liquid present at this point, positive steps must be taken to drain the housing to ensure that liquid does not build up and carry downstream to the analyzer.

The coalescing filter should be located as close to the analyzer as possible to minimize the chance of condensation between the filter and the analyzer. Additional precautions which can be taken to avoid downstream condensation are to cool the sample below ambient temperature upstream from the coalescing filter, and to heat the line.



**Figure 8**  
Stack gas sample lines usually require a high temperature solids filter at the sample point and a condensate separator immediately upstream from the analyzer

# Sample Filters

## Filter Cartridge and Housing Selection

Sample Filters

Table 1 Filter Cartridge Description	
<b>LP Cartridges:</b>	Designed to filter liquids with high solids contents. Have an integral prefilter and an external support structure (flow direction is inside-to-outside).
<b>X-Type Cartridges:</b>	Used for solids and relatively large amounts of suspended liquids in gases. Provide excellent chemical resistance, temperature resistance to 300°F (150°C), and good mechanical handling properties. These cartridges have thick walls for improved coalescing efficiency. Should be used whenever permitted by housing internal volume. Fluorocarbon Resin Binder.
<b>Q-Type Cartridges:</b>	Used for solids and trace amounts of liquids in gases. Also ideal for liquid service and removal of particulates. Similar to X-Type cartridges in chemical and temperature resistance. Fluorocarbon Resin Binder.
<b>H-Type Cartridges:</b>	Recommended for oxygen service or when X-Type or Q-Type are unsuitable. H-Type cartridges have temperature resistance to 1000°F (538°C) in dry gas, 100°F (38°C) in liquid. Quartz construction.
<b>M Type Sintered Stainless Steel Cartridges:</b>	Designed for applications having heavy loading of solid contaminants. These cartridges are also suitable for removing heavy, viscous liquids from gases and as prefilters to high efficiency final filters. Constructed of 316 stainless steel with molded viton end seals.
<b>CI Cartridges:</b>	Used to remove trace quantities of oil vapor. Activated carbon sandwiched between two layers of microfiber filter media absorbs oil vapor. Must be prefiltered with Grade DX and Grade BX. Max. operating temp. is 180°F/82°C.

Table 2 Retention Efficiency of Filter Cartridges for Gas and Liquid Sample Filtration	
<b>Gas Filtration at 0.01 µm</b>	
<b>Microfibre Filter Cartridges</b>	
Grades DX, DQ, DH	93%
Grades BX, BQ, BH	99.99%
Grade AQ	99.9999+%
Grade AAQ	99.99999+%
<b>Liquid and Gas Filtration at Indicated Micron Size</b>	
<b>Sintered SS Cartridges</b>	
Grade 5M	5 µm Nominal
Grade 10M	10 µm Nominal
Grade 20M	20 µm Nominal
Grade 40M	40 µm Nominal
Grade 70M	70 µm Nominal
Grade 00M	100 µm Nominal
<b>Liquid Filtration (98% retention)</b>	
<b>Microfibre Filter Cartridges</b>	
Grades DX, DQ, DH	25 µm
Grades CX, CQ, CH	8 µm
Grades BX, BQ, BH	2 µm
Grade AQ	0.9 µm
Grade AAQ	0.3 µm
<b>LP Cartridges (80% retention)</b>	
Grade 10	75 µm
Grade 20	25 µm
Grade 30	10 µm
Grade 50	1 µm

### Filter Cartridge Description

Parker Hannifin supplies filter cartridges in three different designs: LP Cartridges, Sintered Stainless Steel Cartridges, and Microfibre Filter Cartridges (X, H, or Q-type). See Table 1 for descriptions:

### How To Select The Filter Cartridge

- 1 When selecting a cartridge, do not overspecify. Select the coarsest grade which will adequately protect the instrument. Coarser grade filters provide lower pressure drop and longer life than finer grades.
- 2 When selecting X, Q, or H type cartridges, a D or B positioned before the cartridge type will determine the retention efficiency (see chart to the left). For LP and Sintered Stainless Steel Cartridges, the numerical Grade value indicates retention efficiency (see Table 2).

Refer to the chemical compatibility chart on page 38 to confirm compatibility of the filter cartridge material with the sample composition.

### How To Select The Filter Housing

- 1 Select a filter housing in the material appropriate for your application. Please refer to the Application Index on page 76, and the appropriate data sheet.
- 2 Select a filter housing with a port size equal to the line size where the filter is to be located. If the line size at the filter has not yet been selected, determine the gas flow rate and pressure at the point where the filter will be located, and refer to the appropriate flow chart on pages 77 and 78 of this bulletin. Flow rates for liquids are located on page 77 and flow rates for air and gas sample filters are located on page 78.

# Sample Filters

## Vapor Adsorption Cartridges

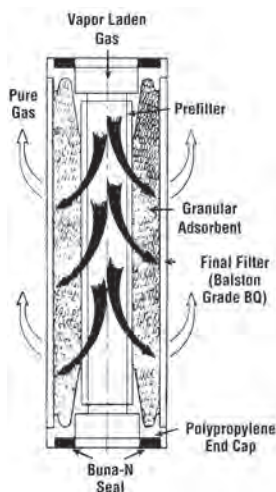

Type CI Vapor Adsorption Cartridges contain a bed of adsorbent granules in the annular space between two Microfibre Filter Tubes, with permanently bonded end caps. Utilizing a wide choice of adsorbents, the Type CI cartridges selectively remove vapors from air and other gases. Flow direction is inside-to-outside through the cartridge, and the outer Microfibre Filter cartridge serves as an integral final filter to prevent carryover of adsorbent particles.

For low flow applications, Disposable Adsorption Units (DAU) provide a means of utilizing the same choice of adsorbents used in the Type CI cartridges in a completely disposable package.

Because the absorbed vapor remains trapped in the solid bed, the Type CI cartridge has a fixed upper limit of total weight of vapor which can be captured. It is usually not feasible to regenerate the cartridge when it has reached its adsorption limit. Type CI cartridges should be used only when small quantities of vapor are to be removed.

### Adsorbents used in Type CI Cartridges

Adsorbent	Grade No.	Use For
<b>Carbon</b>	000	Compressor oil vapors, C <sub>5</sub> and heavier hydrocarbons, aromatics, oxygenated hydrocarbons, chlorinated organics, freons, carbon disulfide.
<b>Molecular Sieve Type 13X</b>	103	Most C <sub>2</sub> and lighter hydrocarbons, ethylene, propylene, acetylene, ethylene oxide, ammonia, mercaptans, sulfur hexafluoride, triethylamine, and smaller amines.
<b>Mixed Sodium and Calcium Hydroxides</b>	107	all acidic gasses, including sulfur trioxide, sulfur dioxide, nitrogen dioxide, carbon dioxide, hydrogen sulfide, hydrogen chloride, phosphorus trichloride, boron trifluoride.

### Considerations in Using Adsorbent Cartridges

The following factors should be considered when selecting a vapor adsorbent cartridge:

- 1 Solid adsorbents are effective only for vapors. Since liquids will damage or inactivate most solid adsorbents, the Type CI cartridge or DAU must be preceded by an efficient coalescing filter.
- 2 In contrast with Microfibre Filters, which operate at their initial efficiency throughout their life, adsorbent cartridges have a limited holding capacity. When the adsorption capacity is reached, no further adsorption occurs. The limiting capacity, or “break-through” point, is not sharply defined, and the exit vapor concentration will increase rapidly as saturation is approached. To avoid unwanted vapor contaminants downstream, it is necessary to change the adsorbent cartridge well before it has reached its ultimate adsorption capacity.
- 3 Adsorption is reversible, if operating conditions change, a vapor may desorb rather than adsorb. For example, if a temporary surge in vapor impurity concentration causes a relatively high concentration to be absorbed on the solid, a subsequent decrease in inlet vapor composition will result in desorption of vapor from the solid to the gas stream.
- 4 The efficiency of a given adsorbent for a given vapor depends upon the specific operating conditions. Therefore, again in contrast to filtration, it is not possible to assign a single efficiency rating to an adsorbent. While it is not possible to predict or guarantee an adsorption efficiency for any specific set of conditions, it is possible to enhance the conditions beneficial to adsorption and avoid conditions which interfere with adsorption. Conditions which aid adsorption are: low temperature, high pressure, low flow rate, and absence of competing vapors (particularly water vapor).

# Sample Filters

## Stainless Steel Sintered Metal Filter

Remove solids and liquids from gas samples

Remove solids from liquid samples

Filtration efficiencies from 5 to 100 micron

316L stainless steel construction

Long life, cleanable filter cartridges

Temperature resistance to 400°F (204°F)

Up to 200 psid (14 barg) (differential pressure)

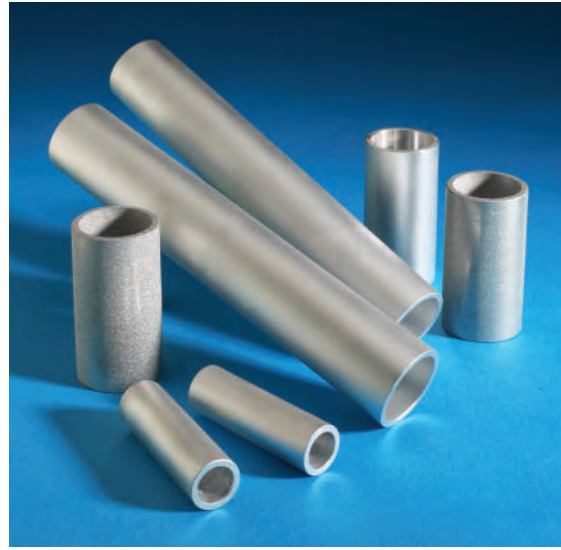

### Advantages

The Balston Stainless Steel Sintered Metal Filter is suitable for applications which require a durable, low maintenance reusable stainless steel filter. The filter cartridge is constructed of 316 stainless steel with two molded Viton gaskets. It may be installed in select Balston filter housings which are designed to accommodate an 050-11, 100-12, and 100-25 size filter cartridge. The Balston Stainless Steel Sintered Metal Filters may be used in liquid or gas service, to filter particulate sized from 5 micron to 100 micron, depending on the grade of the filter used.

The Balston Stainless Steel Sintered Metal Filter has excellent chemical resistance characteristics.

Installation of the Balston Stainless Steel Sintered Metal Filter is straightforward and requires approximately 2-3 minutes. First, remove the filter bowl from the filter housing into which the filter will be installed. Next, place the molded Viton gaskets on to the ends of the cartridge. For 050-11 elements, make sure the shoulder of the gasket fits snugly onto the outer diameter of the cartridge. Finally, holding the gaskets in place on the cartridge, slide the cartridge on the support core or tie rod of the housing, and reassemble the filter housing.

Check the filter housing for leaks after reassembling.

The Balston Stainless Steel Metal Filter Cartridge should be removed from service and cleaned annually, or when the pressure drop across the filter is significant enough to adversely affect the user's application.

The cartridge may be cleaned by backflushing or ultrasonic methods. After cleaning, visually inspect the filter cartridge to confirm it's integrity for continued service.

### Applications

Samples with heavy loading of solid contaminants

Removal of heavy, viscous liquids from gas samples

Prefilters to final high efficiency filters

Ideal for sample lines that are periodically back-flushed

High temperature applications

# Sample Filters

## Stainless Steel Sintered Metal Filter

Sample Filters

Flow Rates (SCFM/Nm <sup>3</sup> /hr) Flow Rates, SCFM (barg), at 2 psi (0.14 bar) drop at indicated line pressure, psig (barg)																
Filter Housing Model	Filter Size	Filter Cartridge Grade	Porosity (Micron)	Max												
				2 psig/ 0.3 barg	20 psig/ 1.3 barg	40 psig/ 2.8 barg	60 psig/ 4.1 barg	80 psig/ 5.5 barg	100 psig/ 6.9 barg	125 psig/ 8.6 barg	160 psig/ 11 barg	200 psig/ 13.8 barg	250 psig/ 17.2 barg	300 psig/ 20.7 barg	500 psig/ 34.5 barg	
95, 85, 91, 48S6 Series	050-11	05M	5	0.8 (1.4)	1.6 (2.7)	2.6 (4.4)	3.6 (6.1)	4.4 (7.5)	5.4 (9.2)	6.6 (11.2)	7.8 (13.3)	10 (17.0)	12 (20.4)	15 (25.5)	24 (40.8)	
			10M	10	1.2 (2.0)	2.4 (4.1)	3.9 (6.6)	5.4 (9.2)	6.6 (11.2)	8.1 (13.8)	9.9 (16.8)	12 (20.4)	15 (25.5)	19 (32.3)	22 (37.4)	36 (61.2)
	100-12	05M	20M	20	1.6 (1.6)	3.2 (3.2)	5.2 (5.2)	7.2 (7.2)	8.8 (8.8)	11 (11.0)	13 (13.0)	16 (16.0)	20 (20.0)	25 (25.0)	30 (30.0)	48 (48.0)
			40M	40	2.4 (4.1)	4.8 (8.2)	7.8 (13.3)	11 (18.7)	13 (22.1)	16 (27.2)	20 (34.0)	23 (39.1)	31 (52.7)	37 (62.9)	44 (74.8)	73 (124.0)
		31G, 33G, 37/12	70M	70	3.4 (5.8)	6.8 (11.6)	11 (18.7)	15 (25.5)	19 (32.3)	23 (39.1)	28 (47.6)	33 (56.1)	43 (73.1)	53 (90.0)	63 (107.0)	103 (175.0)
			00M	100	4.4 (7.5)	8.8 (15.0)	14 (23.8)	20 (34.0)	24 (40.8)	30 (51.0)	36 (61.2)	43 (73.1)	56 (95.1)	68 (115.5)	81 (137.6)	133 (226.0)
31S6, 33S6, 31G, 33G, 37/12	100-12	05M	5	2.4 (4.1)	5.2 (8.8)	8.0 (13.6)	11 (18.7)	14 (23.8)	17 (28.9)	21 (35.7)	24 (40.8)	32 (54.4)	39 (66.3)	47 (79.9)	76 (129.1)	
			10M	10	3.6 (6.1)	7.8 (13.3)	12 (20.4)	17 (28.9)	21 (35.7)	26 (44.2)	31 (52.7)	37 (62.9)	48 (81.6)	69 (117.2)	70 (118.9)	114 (193.7)
	100-25	05M	20M	20	4.8 (8.2)	10 (17.0)	16 (27.2)	22 (37.4)	28 (47.6)	34 (57.8)	41 (70.0)	49 (83.3)	64 (108.7)	78 (132.5)	93 (158.3)	152 (258.2)
			40M	40	7.2 (12.2)	16 (27.2)	24 (40.8)	33 (56.1)	42 (71.4)	51 (86.6)	62 (105.3)	73 (124.0)	95 (161.4)	118 (200.5)	140 (237.9)	229 (389.1)
		31G, 45G, 37/25	70M	70	10 (17.0)	22 (37.4)	34 (57.8)	47 (79.9)	60 (101.9)	72 (122.3)	88 (4.1)	104 (176.7)	135 (229.4)	167 (283.7)	198 (336.4)	324 (550.0)
			00M	100	13 (22.1)	29 (49.3)	44 (74.8)	61 (103.6)	77 (30.8)	94 (159.7)	113 (192.0)	134 (227.7)	175 (297.3)	216 (367.0)	256 (434.9)	419 (711.9)
41S6, 45S6, 41G, 45G, 37/25	100-25	05M	5	3.4 (5.8)	7.2 (12.2)	11 (18.7)	16 (7.2)	20 (34.0)	24 (0.8)	29 (49.3)	34 (57.8)	45 (76.5)	55 (93.4)	66 (112.1)	108 (183.5)	
			10M	10	5.1 (8.7)	11 (17.7)	17 (28.9)	23 (9.1)	30 (51.0)	36 (61.2)	44 (74.8)	52 (88.3)	68 (115.5)	83 (141.0)	99 (168.2)	161 (273.5)
	100-25	05M	20M	20	6.8 (11.6)	14 (23.8)	23 (39.1)	31 (2.7)	40 (68.0)	48 (81.6)	58 (98.5)	69 (117.2)	90 (152.9)	111 (188.6)	132 (224.3)	215 (365.3)
			40M	40	10 (17.0)	22 (37.4)	34 (57.8)	47 (9.9)	59 (100.2)	72 (122.3)	88 (149.5)	103 (175.0)	135 (229.4)	166 (282.0)	197 (334.7)	323 (548.8)
		31G, 45G, 37/25	70M	70	14 (23.8)	31 (52.7)	48 (81.6)	66 (12.1)	84 (142.7)	102 (173.3)	124 (210.7)	146 (248.1)	191 (324.5)	235 (399.3)	280 (475.7)	457 (776.4)
			00M	100	19 (32.3)	40 (68.0)	63 (107.0)	86 (46.1)	109 (185.2)	132 (224.3)	161 (237.5)	189 (321.1)	248 (421.4)	305 (518.2)	362 (615.0)	592 (1,005.8)

Specifications	
<b>Balston Sintered Metal Filter</b>	
Filter Efficiency	5 micron to 100 micron (nominal) in gas and liquid
Materials of Construction	316L Stainless Steel Cartridge, Viton Gasket
Maximum Temperature	400°F (204°C)
Maximum Pressure Drop	200 psid (14 bar)
Dimensions (including gaskets)	
050-11 size	.75"OD x 2.28"L
100-12 size	1.21"OD x 2.48"L
100-25 size	1.21"OD x 6.98"L
Shipping Weight	0.5 lb. (0.2 kg)

Sintered Stainless Steel Cartridges			
Filter Housing Model	Filter Size	Filter Cartridge Grade	Water Flow Rate in GPH at 1 PSI pressure drop
95, 85, 91	050-11	05M	11
		10M	26
		20M	30
		40M	35
		70M	38
		00M	38
31S6, 33S6, 31G, 33G, 37/12	100-12	05M	26
		10M	62
		20M	71
		40M	82
		70M	93
		00M	93
41S6, 45S6, 41G, 45G, 37/25	100-25	05M	61
		10M	111
		20M	128
		40M	148
		70M	154
		00M	154

Ordering Information for assistance, call 800-343-4048. 8am to 5pm Eastern Time.			
	050-11 Size	100-12 Size	100-25 Size
Sintered Metal Filter	050-11(-)	100-12(-)	100-25(-)
Replacement Viton Gaskets	A05-0045	A05-0046	A05-0046
Example: 100-12-40M			

# Sample Filters

## Chemical and Temperature Resistance Selection

### Chemical and Temperature Resistance of Filter Cartridges (For Temperatures Up To 75°F/24°C)\*

Chemical or Solvent	X-Type or Q-Type with Fluorocarbon Resin Binder	H-Type With Quartz Construction	LP Cartridge With Polypropylene Support
Cold Water	Excellent	Fair	Excellent
Hot Water (to 180°F/82°C)	Excellent	Not Recommended	Excellent
Steam (to 20 psig/1.4 barg)	Excellent	Not Recommended	Not Recommended
Acids, except Hydrofluoric:			
Dilute concentrations	Excellent	Excellent	Excellent
Intermediate concentrations	Excellent	Excellent	Good
Concentrated, except phosphoric	Good-Fair	Excellent	Not Recommended
Concentrated phosphoric acid	Not Recommended	Not Recommended	Not Recommended
Hydrofluoric Acid	Not Recommended	Not Recommended	Not Recommended
Caustic, below 45%	Excellent	Not Recommended	Fair
Caustic, above 45%	Fair	Not Recommended	Not Recommended
Chlorine, liquid or gas	Excellent	Excellent	Not Recommended
Ammonia, liquid or gas	Not Recommended	Not Recommended	Fair
Ethylene Oxide, liquid or gas	Not Recommended	Not Recommended	See Pack 5
Aromatic Hydrocarbons	Excellent	Excellent	Good
All other Hydrocarbons	Excellent	Excellent	Excellent
Ketones	Not Recommended	Excellent	Fair
Alcohols	Excellent	Excellent	Excellent
Freons	Excellent	Excellent	Not Recommended
Phenol	Excellent	Excellent	Not Recommended
Chlorinated Solvents	Excellent	Excellent	Fair
Ethylene Diamine	Excellent	Excellent	Not Recommended
Ethanolamine	Not Recommended	Excellent	Not Recommended
Other Amines	Good-Fair	Excellent	Not Recommended
Polar Solvents, including: DMF, DMAC, NMP, DMSO	Not Recommended	Excellent	Not Recommended
Maximum Operating Temperature	300°F (150°C)	1000°F (538°C)	180°F (82°C)

\*Consult factory for compatibility at elevated temperatures

### Application Index

Operating Requirement	Filter Cartridge Type	Stainless Steel, Monel, or Aluminum Housing	Plastic Housing
<b>Severe Operating Conditions</b>			
Pressure 250 to 5000 psig (17.2 to 345 barg)	All	91S6, 97S6, 95M, 85, 37/12, 37/25, 27/35, 27/80, 95S6, 95A, 48S6, 49S6, 105S6, 47S6	N/A
Temperature 300°F (150°C) to 600°F (315°C)	H, M	Any stainless steel or Monel housing with Viton seals	N/A
Temperature 600°F (315°C) to 900°F (480°C)	H, M	30/12, 30/25	N/A
Exceptional Chemical Resistance	See chart above	95M/Monel	9922-□-□, 8822□-□/PVDF, 95T/PTFE 90/Polypropylene
NACE Compliance	All	95S6, 85, 37/12, 37/25, 27/35, 27/80	NA
<b>Functional Requirements</b>			
Separate liquids from gases	X, Q	All housings except 97S6, 30/12, 30/25, 48S6, 49S6, 47S6	8822-11, 8833-11, 95T
Separate two liquid phases	X, LP	All housings except 97S6, 30/12, 30/25, 48S6, 49S6, 47S6	8822-11, 8833-11, 95T
Remove gas bubbles from liquids	X, Q	All housings except 97S6, 30/12, 30/25, 48S6, 49S6, 47S6	8822-11, 95T
Quantitative measurement of solids in gases	H, Q	30/12, 30/25	N/A
Slipstream or Bypass Filtration	X, Q, LP, M	All housings except 97S6, 30/12, 30/25	8822-11, 95T, 53/18, 53/50
Filter liquids with high solids content	LP, M	All housings	All housings
Filter gas or liquid samples to analyzers	X, Q, LP, M	All housings	9933-05, 9922-05, 90



# Sample Filters

## Filter Cartridge, Housing Selection/Flow Rates for Liquid Filters

Flow Rates For Liquid Filters			Water Flow Rate, Gallons Per Hour						
Filter Housing Model	Volume of Housing Gallons      Liters		Initial Pressure Drop	Q or X Cartridges		LP Cartridges			
				DQ, DX	BQ, BX	Grade 10	Grade 20	Grade 30	Grade 50
<b>Stainless Steel, Monel and PTFE Housings</b>									
105S6			1 psi (0.07 bar)	7 (0.44)	2 (0.13)	---	---	---	---
			5 psi (0.34 bar)	24 (1.51)	10 (0.63)	---	---	---	---
48S6			1 psi (0.07 bar)	14 (0.88)	4 (0.25)	---	---	---	---
			5 psi (0.34 bar)	51 (3.22)	21 (1.32)	---	---	---	---
95M, 95S6, 95T, 95A 91S6, 47S6 85	0.005 .009 0.015	0.02 0.036 0.06	1 psi (0.07 bar)	18 (1.14)	5 (0.32)	---	---	---	---
			5 psi (0.34 bar)	64 (4.04)	26 (1.64)	---	---	---	---
31S6	0.026	0.098	1 psi (0.07 bar)	54 (3.41)	13 (0.82)	---	---	---	---
31G			5 psi (0.34 bar)	129 (8.14)	56 (3.53)	---	---	---	---
49S6			1 psi (0.07 bar)	57 (3.60)	14 (0.88)	---	---	---	---
			5 psi (0.34 bar)	135 (8.52)	60 (3.79)	---	---	---	---
33S6 33G 37/12	0.042	0.16	1 psi (0.07 bar)	63 (3.97)	16 (1.01)	50 (3.15)	50 (3.15)	40 (2.52)	10 (0.63)
			5 psi (0.34 bar)	150 (9.46)	66 (4.16)	210 (13.25)	210 (13.25)	180 (11.36)	45 (2.84)
41S6	0.051	0.19	1 psi (0.07 bar)	95 (5.99)	30 (1.89)	---	---	---	---
41G			5 psi (0.34 bar)	260 (16.40)	121 (7.63)	---	---	---	---
37/25 45S6 45G	0.111	0.42	1 psi (0.07 bar)	109 (6.88)	35 (2.21)	75 (4.73)	75 (4.73)	60 (3.79)	15 (0.95)
			5 psi (0.34 bar)	300 (18.93)	140 (8.83)	300 (18.93)	300 (18.93)	260 (16.40)	65 (4.10)
27/35	0.394	1.49	1 psi (0.07 bar)	325 (20.50)	90 (5.68)	---	---	---	---
			5 psi (0.34 bar)	875 (55.20)	400 (25.24)	---	---	---	---
27/80	0.750	2.84	1 psi (0.07 bar)	390 (24.61)	170 (10.73)	---	---	---	---
			5 psi (0.34 bar)	990 (62.46)	610 (38.49)	---	---	---	---
15/80S6 (2)			1 psi (0.07 bar)	1650 (104.10)	720 (45.42)	---	---	---	---
			5 psi (0.34 bar)	4000 (252.36)	2500 (157.73)	---	---	---	---
<b>Plastic Housings</b>									
9922-05	0.003	0.01	1 psi (0.07 bar)	12 (0.76)	3 (0.19)	---	---	---	---
9933-05			5 psi (0.34 bar)	30 (1.89)	15 (0.95)	---	---	---	---
8822-11, 8833-11	0.005	0.02	1 psi (0.07 bar)	18 (1.14)	5 (0.32)	---	---	---	---
9922-11, 9933-11			5 psi (0.34 bar)	45 (2.84)	26 (1.64)	---	---	---	---
8800-12			1 psi (0.07 bar)	54 (1.14)	13 (0.32)	---	---	---	---
			5 psi (0.34 bar)	129 (2.84)	56 (1.64)	---	---	---	---
90			1 psi (0.07 bar)	23 (1.45)	10 (0.63)	---	---	---	---
			5 psi (0.34 bar)	46 (.90)	36 (2.27)	---	---	---	---
58P	0.034	0.13	1 psi (0.07 bar)	---	---	50 (3.15)	50 (3.15)	40 (2.52)	10 (0.63)
			5 psi (0.34 bar)	---	---	210 (13.25)	210 (13.25)	180 (11.36)	45 (2.84)
53/18	0.185	0.70	1 psi (0.07 bar)	---	---	100 (6.31)	100 (6.31)	100 (6.31)	40 (2.52)
			5 psi (0.34 bar)	---	---	360 (22.71)	360 (22.71)	360 (22.71)	190 (11.99)
53/50	0.346	1.31	1 psi (0.07 bar)	---	---	210 (6.31)	210 (6.31)	210 (6.31)	80 (2.52)
54/50			5 psi (0.34 bar)	---	---	720 (22.71)	720 (22.71)	720 (22.71)	390 (11.99)
53/95	0.661	2.50	1 psi (0.07 bar)	---	---	420 (26.50)	420 (26.50)	420 (26.50)	160 (10.09)
			5 psi (0.34 bar)	---	---	1440 (90.85)	1440 (90.85)	1440 (90.85)	780 (49.21)

**Notes:** 1 For liquids with viscosity higher than the viscosity of water (1 centipoise), divide the flow rates in the above table by the viscosity of the liquid in centipoises.  
 Example: For liquid with 10 centipoise viscosity, flow rate with Model 53/50 housing, Grade 50 filter cartridges at 5 psi (0.34 bar) drop will be 390/10=39 GPH (2.5 lpm).  
 2 Flow rates for Model 15/80S6 are estimated.

# Flow Rates for Air and Gas Filters

Filter \Housing Model	Volume of Housing (ml)	Filter Tube Grade	Flow Rate (CFM) at 10" Water Press. Drop																								
			(1) Flow Rates, SCFM, at 2 PSI Drop at Indicated Line Pressure, PSIG Refer to Product Specification Charts for Maximum Pressure Rating of Each Housing																								
			0 psig	2 psig	20 psig	40 psig	60 psig	80 psig	100 psig	125 psig	150 psig	175 psig	200 psig	250 psig	300 psig	500 psig	750 psig	1000 psig	1500 psig	2000 psig	2500 psig	3000 psig	3500 psig	4000 psig	4500 psig	5000 psig	
9922-05	11.33	DQ	0.2	1.2	2.5	3.9	5.4	6.8	8.3	10.1	---	---	---	---	---	---	---	---	---	---	---	---	---	---	---	---	
4433-05		BQ	0.1	0.8	1.6	2.6	3.5	4.5	5.4	6.6	---	---	---	---	---	---	---	---	---	---	---	---	---	---	---	---	
9900-05		DAU	N/A	0.5	1.2	---	---	---	---	---	---	---	---	---	---	---	---	---	---	---	---	---	---	---	---	---	---
9933-05																											
8833-11																											
9922-11	19.82	DX	0.4	1.8	3.6	6	8	10	12	14.6	---	---	---	---	---	---	---	---	---	---	---	---	---	---	---	---	
9933-11		BX	0.2	0.9	1.8	3	4	5	6	7.3	---	---	---	---	---	---	---	---	---	---	---	---	---	---	---	---	
105S6	16	DAU	N/A	0.7	1.7	3.7	5.7	7.7	10	14.6	32	41	52	60	99	147	195	290	386	482	578	674	770	866	962		
97S6	11.33	DQ	0.7	3	7	10	14	18	22	27	32	41	51	60	99	147	195	290	386	482	578	674	770	866	962		
		BQ	0.2	0.9	1.8	3	4	5	6	7	9	11	14	16	26	39	52	77	103	128	154	179	205	230	256		
95A, 95M	19.82	DQ	1.5	3.9	8	13	18	22	27	33	39	51	62	74	121	180	239	357	470	590	710	830	940	1060	1180		
95S6, 95T		BQ	1.5	0.3	3	5	7	8	10	12	14	19	23	27	45	67	88	132	180	220	260	310	350	390	440		
91S6, 47S6																											
48S6	21	DQ	N/A	2.5	10	16	23	28	33	40	47	61	75	89	145	210	280	420	560	700	840	980	1120	1260	1400		
		BQ	N/A	2	5	8	9	10	11	13	16	20	25	29	46	70	90	130	180	220	260	300	340	380	420		
85	59.47	DX	2.2	5.9	12	19.5	26	32	41	50	58	76	92	111	182	270	360	540	710	890	1065	1245	1420	1600	1770		
		BX	0.4	2.2	4.6	7.7	10	12	15	18	22	28	34	41	68	113	134	200	265	325	400	475	530	590	660		
90	23.3	DQ, DX	3.0	---	---	---	---	---	---	---	---	---	---	---	---	---	---	---	---	---	---	---	---	---	---		
		BQ, BX	0.5	---	---	---	---	---	---	---	---	---	---	---	---	---	---	---	---	---	---	---	---	---	---		
8800-12 (2)	93.45	DQ, DX	2.6	10	22	35	48	61	74	90	107	140	172	205	---	---	---	---	---	---	---	---	---	---	---	---	
31S6, 31G		BQ, BX	0.45	2	6	9	12	16	20	24	29	37	46	54	---	---	---	---	---	---	---	---	---	---	---	---	
		DAU	1.5	4.5	6.8	---	---	---	---	---	---	---	---	---	---	---	---	---	---	---	---	---	---	---	---		
30/12, 33S6	158.58	DX	3.0	12	26	40	55	70	85	103	122	159	196	233	381	567	752	1122	1493	1863	2234	2600	2970	3340	3710		
33G, 37/12		BX	0.5	3	7	10	14	18	22	27	32	41	51	60	99	147	195	291	387	483	579	695	770	845	920		
49S6	170	DQ	N/A	13	28	45	61	78	94	115	135	177	218	259	423	629	834	1245	---	---	---	---	---	---	---		
		BQ	N/A	6	13	21	28	35	43	53	62	81	100	119	194	288	383	571	---	---	---	---	---	---	---		
41S6, 41G	220.87	DQ, DX	6.6	15	32	50	69	87	106	129	152	199	245	291	---	---	---	---	---	---	---	---	---	---	---		
		BQ, DX	1.1	7	15	24	32	41	50	61	72	93	115	139	---	---	---	---	---	---	---	---	---	---	---		
30/25	419.09	DQ, DX	7.5	17	36	57	78	99	120	146	172	225	277	329	538	800	1062	1585	2108	2631	3156	3680	4200	4720	5240		
45S6, 45G		BQ, BX	1.3	8	17	26	36	45	55	67	79	103	127	151	247	367	487	727	976	1207	1447	1690	1930	2170	2410		
37/25																											
27/35	1500.80	DX	13.3	40	83	130	178	225	273	332	392	510	629	748	1220	1820	2410	3600	4780	5970	7160	8340	9530	10720	11900		
26/35		BX	3.3	19	39	62	84	107	129	157	185	241	297	353	578	858	1140	1700	2260	2820	3380	3940	4500	5060	5630		
27/80	2860.02	DX	20.0	43	90	142	193	245	297	362	426	555	684	814	1330	1980	2625	3900	---	---	---	---	---	---	---		
		BX	5.8	28	59	93	127	161	195	237	280	365	449	534	873	1300	1722	2540	---	---	---	---	---	---	---		
15/80S6	4700	DX	20.0	160	333	525	717	908	1100	1340	1580	2060	2540	3020	4940	---	---	---	---	---	---	---	---	---	---		
		BX	5.8	45	94	148	202	256	310	378	445	580	715	850	1390	---	---	---	---	---	---	---	---	---	---		

NA = DATA NOT AVAILABLE

1 For line pressures above 150 PSIG, flow rate values are estimated.

2 Maximum operating pressure in gas service is 50 PSIG.

# Metric Flow Rates for Air and Gas Filters

Filter / Housing Model	Volume of Housing (ml)	Filter Tube Grade	Flow Rate (l/m <sup>2</sup> /hr) at 26 cm Water Press. Drop.																				
			(1) Flow Rates, Nm <sup>3</sup> /hr, at 0.14 BAR Drop at Indicated Line Pressure, BARC Refer to Product Specification Charts for Maximum Pressure Rating of Each Housing																				
			0.14 barg	1.14 barg	3 barg	4 barg	6 barg	7 barg	9 barg	10 barg	14 barg	17 barg	21 barg	35 barg	52 barg	69 barg	103 barg	138 barg	172 barg	207 barg	241 barg	276 barg	310 barg
9922-05 4433-05 9900-05 9933-05	11.33	DQ BQ DAU	2.039	4.248	6.626	9.175	11.55	14.1	17.16	---	---	---	---	---	---	---	---	---	---	---	---	---	---
8833-11 9922-11 9933-11 105S6	19.82 16	DX BX DAU	3.058	6.116	10.19	13.59	16.99	20.39	24.81	---	---	---	---	---	---	---	---	---	---	---	---	---	---
97S6	11.33	DQ	5.097	11.89	16.99	23.79	30.58	37.38	45.87	54.37	69.66	86.65	101.9	168.2	249.8	331.3	492.7	655.8	818.9	982	1145	1308	1505
95A, 95M 95S6, 95T 91S6, 47S6	19.82	DQ BQ	6.626	13.59	22.09	30.58	37.38	45.87	56.07	66.26	86.65	105.3	125.7	205.6	305.8	406.1	606.5	798.5	982	1206	1410	1597	2005
48S6	21	DQ BQ	4.248	16.99	27.18	39.08	47.57	56.07	67.96	79.85	103.6	127.4	151.2	246.4	356.8	475.7	713.6	951.4	1189	1427	1665	1903	2379
85	59.47	DX BX	10.02	20.39	33.13	44.17	54.37	69.66	84.95	98.54	129.1	156.3	188.6	309.2	458.7	611.6	917.5	1206	1512	1809	2115	2413	3007
90	23.3	DQ, DX BQ, BX	5.097	---	---	---	---	---	---	---	---	---	---	---	---	---	---	---	---	---	---	---	---
8800-12 (2) 31S6, 31G	93.45	DQ, DX BQ, BX DAU	16.99	37.38	59.47	81.55	103.6	125.7	152.9	181.8	237.9	292.2	348.3	---	---	---	---	---	---	---	---	---	---
30/12, 33S6 33G, 37/12	158.58	DX BX	20.39	44.17	67.96	93.45	118.9	144.4	175	207.3	270.1	333	395.9	647.3	963.3	1278	1906	2537	3165	3796	4417	5046	
49S6	170	DQ BQ	22.09	47.57	76.46	103.6	132.5	159.7	195.4	229.4	300.7	370.4	440	718.7	1069	1417	2115	---	---	---	---	---	
41S6, 41G	220.87	DQ, DX BQ, DX	54.37	84.95	117.2	147.8	180.1	219.2	258.2	338.1	416.3	494.4	---	---	---	---	---	---	---	---	---	---	---
30/25 45S6, 45G 37/25	419.09	DQ, DX BQ, BX	28.88	61.16	96.84	132.5	168.2	203.9	248.1	292.2	382.3	470.6	559	914.1	1359	1804	2693	3581	4470	5362	6252	7136	
27/35 26/35	1500.80	DX BX	67.96	141	220.9	302.4	382.3	463.8	564.1	666	866.5	1069	1271	2073	3092	4095	6116	8121	10143	12165	14170	16191	
27/80	2860.02	DX BX	33.98	152.9	241.3	236.2	416.3	504.6	615	723.8	942.9	1164	1383	2260	3364	4460	6626	---	---	---	---	---	
15/60S6	4700	DX BX	33.98	271.8	565.8	892	1218	1543	1869	2277	2884	3500	4315	5131	8393	---	---	---	---	---	---	---	

1 For line pressures above 150 PSIG, flow rate values are estimated.

2 Maximum operating pressure in gas service is 50 PSIG.

NA = DATA NOT AVAILABLE

# Sample Filters

## Miniature Disposable Filter Units Constructed of Nylon and PVDF

Prevent cross-contamination of samples

Pressure ratings up to 125 psig (8.62 barg)

Temperature to 275°F (135°C)

Completely disposable, constructed of recyclable plastics

### Models 9922-05, 9933-05, 4433-05 and 9900-05

The 99XX-05 models are the smallest Disposable Filter Units with 11.7 ml internal volume. These models are used in low flow gas or liquid sampling applications, such as liquids to specific-ion analyzers or gases to personal samplers. The model 9900-05-BK has a color indicating feature, which turns the cartridge red when saturated with oil. The model 4433-05 has 1/4" and 3/8" Barb Connections molded into the inlet/outlet ports.

### Models 9922-11, 9933-11, and 8800-12

Models 9922-11, 9933-11, and 8800-12 are used for applications similar to the smaller DFUs (Models 9922-05 and 9933-05) which require greater solids holding capacity and can tolerate the increased retention time.

### Model 8833-11

These Disposable Filter Units are used as continuous coalescing filters with a third port serving as the drain, slip-stream, or by-pass port.

Parker Hannifin offers a manual drain valve for removal of coalesced liquids from the Type 8833-11-DX.

Drain Valve: 1/8" NPT (male) x 1/8" ID Tubing.  
(Requires fitting part No. 11977). Part No. 20120.

### Model 9953-11

This model snaps together for easy filter cartridge changeouts. It is designed primarily for low pressure or mild vacuum applications. It is ideal for capturing samples and perform analysis or record weights over time. If used with a X-tube, it is a very effective silencer to compress inlet noise to small pumps.

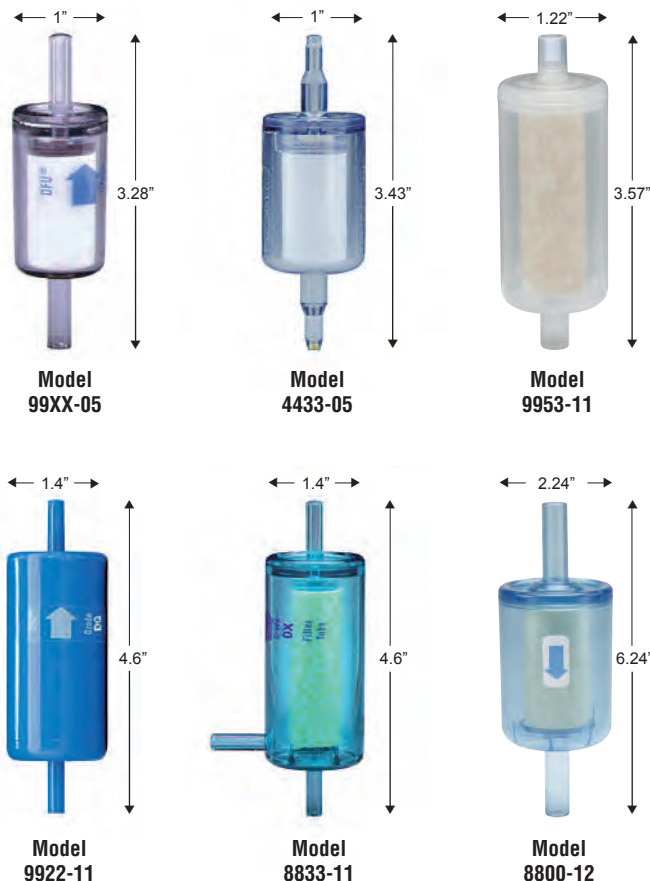

#### Chemical Compatibility Models 9922-05, 9922-11

**Suitable:** Water or steam to 200°F (135°C); concentrated nitric, sulfuric, and hydrochloric acids; chlorine (gas or liquid); sodium hypochlorite, ethylene oxide (gas or liquid); Freons; ammonia (gas, liquid, or aqueous solutions); hydrogen peroxide (all concentrations); bromine (dry and aqueous solutions); all chlorinated solvents except methylene chloride; all aromatic and aliphatic solvents; all alcohols and glycols; aniline; phenol.

**Limited Use:** Acetone, MEK, dioxane, furfural, methylene chloride.

**Unsuitable:** Water above 200°F (135°C), THF, DMF, ethylene diamine, chlorosulfonic acid, ethanolamine, pyridine, sulfur trioxide.

#### Chemical Compatibility Model 9933-11, 8833-11, and 8800-12

**Suitable:** Water to 158°F (70°C); benzene, toluene, other aromatic hydrocarbons; hydrocarbon solvents and fuels, perchloroethylene; trichloroethylene, nitric acid (to 10%); sulfuric acid (to 40%); hydrochloric acid (to 10%); most salt solutions; sodium and potassium hydroxide (to 50%).

**Limited Use:** Water at 158°F (70°C); acetone; MEK, acetaldehyde; ammonia (to 25%).

**Unsuitable:** Water above 176°F (80°C); alcohols; glycols; phenol; aniline; DMF; concentrated acids; chlorine.

# Sample Filters

## Miniature Disposable Filter Units Constructed of Nylon and PVDF

Flow Rates Water Flow Rate, Gallons per Hour

DFU Model	Volume of Housing Gallons	Liters	Initial Pressure Drop	Grade DQ, DX	Grade CQ, CX	Grade BQ, BX	Grade AQ	Grade AAQ
9922-05 4433-05 9933-05	0.003	0.01	1 psi (0.07 bar) 5 psi (0.34 bar)	12 (0.76) 30 (1.90)	10 (0.63) 25 (1.58)	3 (0.19) 15 (0.95)	1.5 (0.09) 7.3 (0.46)	0.4 (0.03) 1.9 (0.12)
9922-11 9933-11	0.0005	0.02	1 psi (0.07 bar) 5 psi (0.34 bar)	18 (1.14) 45 (2.84)	15 (0.95) 37 (2.33)	5 (0.34) 26 (1.64)	2.5 (0.16) 12 (0.76)	0.6 (0.04) 3.1 (0.20)
8800-12	.003	.014	1 psi (0.07 bar) 5 psi (0.34 bar)	54 (3.74) 129 (8.89)	44 (3.03) 106 (7.31)	13 (0.90) 56 (3.86)	6 (0.41) 26 (1.79)	1.4 (0.10) 6.5 (0.45)

Sample Filters

### Principal Specifications

Model	9922-05	9900-05	4433-05	9933-05	9922-11	9933-11	8833-11	8800-12	9953-11
Inlet and Outlet Ports	1/4" Tubing	1/4" Tubing	1st Tier/Barb 1/4" Tube 2nd Tier/Barb 3/8" Tube	1/4" Tubing	1/4" Tubing	1/4" Tubing	1/4" Tubing	1/2" Tubing	0.32" OD
Drain	None	None	None	None	None	None	1/4" Tubing	None	None
Material of Construction	PVDF	Nylon	Nylon	Nylon	PVDF	Nylon	Nylon	Nylon	Polypropylene
Filter Cartridge Length	1.25" (3.2 cm)	1.25" (3.2 cm)	1.25" (3.2cm)	1.25" (3.2 cm)	2.25" (5.7 cm)	2.25" (5.7 cm)	2.25" (5.7 cm)	2.5" (5.71 cm)	2.28" 6.35 cm)
Maximum Temperature	275°F (135°C)(1)	230°F (110°C)(1)	230°F (110°C)(1)	230°F (110°C)(1)	275°F (135°C)(1)	230°F (110°C)(1)	230°F (110°C)(1)	150°F (66°C)(1)	125°F (52°C)(1)
Maximum Pressure	125 psig (8.6 barg) (2)	125 psig (8.6 barg) (2)	125 psig (8.6 barg) (2)	125 psig (8.6 barg) (2)	125 psig (8.6 barg) (2)	125 psig (8.6 barg) (2)	125 psig (8.6 barg) (2)	50 psig (3.03 barg) (2) (8)	2 psig (0.14 barg) (2)
Dimensions	1.0"D x 3.25"L (2.5 cm x 8 cm)	1.0"D x 3.25"L (2.5 cm x 8 cm)	1.0"D x 3.43"L (2.5 cm x 8.72 cm)	1.0"D x 3.25"L (2.5 cm x 8 cm)	1.4"D x 4.6"L (3.6 cm x 12 cm)	1.4"D x 4.6"L (3.6 cm x 12 cm)	1.4"D x 4.6"L (3.6 cm x 12 cm)	2.24"D x 6.24"L (5.69 cm x 15.85 cm)	1.22"D x 3.57"L (3.1 cm x 9.07 cm)

#### Notes:

**1** At 0 psig  
**2** At 110°F (43°C)

**3** To designate adsorbent in the DAU, insert adsorbent numbers after DAU designation. For example, to obtain a miniature clear nylon DAU

with carbon adsorbent, order 9933-05-000. Adsorbent numbers are listed on page 73.  
**4** Available only in Q grades.

**5** Available in Q or X media.  
**6** Available only in X media.  
**7** 9953-11 is designed for maximum pressure of 2 psig.

**8** Pressure rating in liquid service is 70 PSIG (4.83 barg) maximum.

# Sample Filters

## Miniature Disposable Filter Units Constructed of Nylon and PVDF

### Ordering Information

For assistance, call toll-free at 1-800-343-4048 8AM to 5PM Eastern Time

Model	9922-05	9900-05	4433-05	9933-05	9922-11	9933-11	8833-11	8800-12	9953-11
Box of 10 DFUs Available only in Q-grades	9922-05-□	9900-05-□ (4)	4433-05-□ (4)	9933-05-□	9922-11-□	9933-11-□	8833-11-□ (6)	8800-12-□ box of 1	9953-11-□ (5)
Box 10 DAU'S (3)	9922-05-□	N/A	N/A	9933-05-□	9922-11-□	9933-11-□	N/A	N/A	N/A

#### Notes:

**1** At 0 psig  
**2** At 110°F (43°C)

**3** To designate adsorbent in the DAU, insert adsorbent numbers after DAU designation. For example, to obtain a miniature clear nylon DAU

with carbon adsorbent, order 9933-05-000. Adsorbent numbers are listed on page 73.  
**4** Available only in Q grades.

**5** Available in Q or X media.  
**6** Available only in X media.  
**7** 9953-11 is designed for maximum pressure of 2 psig.

**8** Pressure rating in liquid service is 70 PSIG (4.83 barg) maximum.

### Installation Information

**To pressure pipe or tubing:** Compression fittings for 1/4" O.D. tubing may be obtained from the following manufacturers. Hoke, Inc. ("Gyrolok"); Crawford Fitting Co. ("Swagelok"); Parker-Hannifin Corp. ("CPI"); Legris, Inc. (push-on fittings); Jaco Mfg. Co. (plastic fittings). The following brass fittings which seal by O-ring compression and which may be completely recovered and reused when changing filters may be purchased from Parker/Balston:

Connector: 1/4" tubing to 1/4" NPT female - Part No. 11970 (1 per pkg.)

Connector: 1/4" tubing to 1/4" tubing - Part No. 11971 (1 per pkg.)

**To low pressure plastic tubing:** Tubing with 1/4" ID may be slipped over the DFU and fittings and held with tubing clamps. Parker Hannifin supplies plastic barbs to connect the DFU to smaller diameter plastic tubing. The connection is suitable for pressures to 50 psig.

DFU to 1/16" ID tubing: Part No. 14000 (bag of 20 barbs)

DFU to 1/8" ID tubing: Part No. 14001 (bag of 20 barbs)

# Sample Filters

## Stainless Steel In-Line Filter Housings: 1/4" and 1/2" Port Size

Stainless steel construction

Pressure to 5000 psig (345 barg)

Temperature to 600°F (315°C)

Ideal end use filter

### Model 97S6

Miniature 316 stainless steel filter with 1/4" NPT in-line ports, and 5000 psig (345 barg) rating. Since it does not have a drain port, the Model 97S6 is used as an end-of-the-line compressed gas filter when little or no liquid is expected, or as a cylinder gas filter.



Model 97S6



Model 30/12 and 30/25

Sample  
Filters

### Models 30/12 and 30/25

Designed specifically for quantitative measurement of solids in gases to 600°F (315°C), the filter cartridge and element retainer disc in the Model 30 housings may be weighed as a unit (see notes below).

#### Principal Specifications

Model	97S6	30/12	30/25
Inlet and Outlet Ports	1/4" NPT	1/2" NPT	1/2" NPT
Drain Port	None	None	None
Materials of Construction			
Head	316SS	303SS	303SS
Bowl	316SS	304SS	304SS
Internals	316SS	303SS	303SS
Seals	Viton	Carbon Fiber	Carbon Fiber
Maximum Temperature	400°F (204°C)	600°F (315°C) (2)	600°F (315°C)(2)
Maximum Pressure	5000 psig (345 barg) (1)	100 psig (6.89 barg) (3)	100 psig (6.89 barg) (3)
Shipping Weight	0.75 lbs. (0.3 kg)	2 lbs. (0.9 kg)	3 lbs. (1.4 kg)
Dimensions	1.25"D X 3.1"L (3.2cm X 7.9cm)	1.9"D X 4.4"L (4.8cm X 11.2cm)	1.9"D X 8.6"L (4.8cm X 22cm)

#### Notes:

- 1 Maximum pressure ratings are for temperatures to 200°F (93°C). Please consult factory for maximum pressure ratings at elevated temperatures.
- 2 For temperatures greater than 600°F (315°C) consult factory for proper recommended seals
- 3 100 psig at 450°F (241°C).

#### Ordering Information

For assistance, call toll-free at 1-800-343-4048 8AM to 5PM Eastern Time

Filter Housing Model	97S6	30/12	30/25
Support Core, Required for Liquid Filtration	Included	N/A	N/A
Filter Cartridges	050-05-□	100-12-□	100-25-□
Important Notes:	X-type cartridges are not available for the Model 97S6. For high temperature quantitative measurement applications order 100-12-DH/BH-F896 for use with the 30/12 or 100-25-DH/BH-F896 for use with the 30/25.		

# Sample Filters

## Filter Cartridge and Housing Selection



Disposable Adsorption Units (DAUs) contain a bed of adsorbent granules. Utilizing a wide choice of adsorbents, the DAUs selectively remove vapors from air and other gases.

Because the adsorbed vapor remains trapped in the solid bed, the DAU has a fixed upper limit of total weight of vapor which can be captured. It is usually not feasible to regenerate the filter when it has reached its adsorption limit. DAUs should be used only when small quantities of vapor are to be removed.

### Considerations in Using Adsorbent Cartridges

The following factors should be considered when selecting a DAU:

- 1 Solid adsorbents are effective only for vapors. Since liquids will damage or inactivate most solid adsorbents, the DAU must be preceded by an efficient coalescing filter.
- 2 In contrast with Microfibre Filters, which operate at their initial efficiency throughout their life, adsorbent cartridges have a limited holding capacity. When the adsorption capacity is reached, no further adsorption occurs. The limiting capacity, or “break-through” point, is not sharply defined, and the exit vapor concentration will increase rapidly as saturation is approached. To avoid unwanted vapor contaminants downstream, it is necessary to change the adsorbent cartridge well before it has reached its ultimate adsorption capacity.
- 3 Adsorption is reversible, if operating conditions change, a vapor may desorb rather than adsorb. For example, if a temporary surge in vapor impurity concentration causes a relatively high concentration to be adsorbed on the solid, a subsequent decrease in inlet vapor composition will result in desorption of vapor from the solid to the gas stream.
- 4 The efficiency of a given adsorbent for a given vapor depends upon the specific operating conditions. Therefore, again in contrast to filtration, it is not possible to assign a single efficiency rating to an adsorbent. While it is not possible to predict or guarantee an adsorption efficiency for any specific set of conditions, it is possible to enhance the conditions beneficial to adsorption and avoid conditions which interfere with adsorption. Conditions which aid adsorption are: low temperature, high pressure, low flow rate, and absence of competing vapors (particularly water vapor).

Adsorbent	Grade	Use For
Carbon	000	Compressor oil vapors, C <sub>5</sub> and heavier hydrocarbons, aromatics, oxygenated hydrocarbons, chlorinated organics, freons, carbon disulfide.
Silica Gel	101	Recommended only for water vapor.
Molecular Sieve Type 13X	103	Most C <sub>4</sub> and lighter hydrocarbons, ethylene, propylene, acetylene, ethylene oxide, ammonia, mercaptans, sulfur hexafluoride, triethylamine, and smaller amines.
Mixed Sodium & Calcium Hydroxides	107	All acidic gases, including sulfur trioxide, sulfur dioxide, nitrogen dioxide, carbon dioxide, hydrogen sulfide, hydrogen chloride, phosphorus trichloride, boron trifluoride.

#### Notes:

1 Please refer to Ordering Information for complete explanation of nomenclature.

2 In DAU 9933-05-107 and DAU 9933-11-107, color indicator turns violet when adsorbent is spent.

3 In DAU 9933-05-101 and 9933-11-101, adsorbent turns pink when vapor capacity is reached.

4 Maximum operating temperature is 180°F (82°C).



# Sample Filters

## Balston OEM Disposable Filter Solutions



### Balston Disposable Filter Units

#### Ideal for the following gas filtration applications:

- Final filter for air logic devices
- Protection of pneumatic components
- Filtration of portable environmental sampling devices
- Filtration of samples to on-line analyzers
- Protection of Pneumatic temperature controls

#### Ideal for the following liquid filtration applications:

- Filtration of liquid with minimum holdup volume
- Filtration of liquid samples to analyzers

#### Additional applications in the following industries:

- Instrument & Controls
- HVAC
- Dental
- Automotive
- Food Packaging

This section is designed to help customers choose the best Balston disposable filter product for industrial, commercial, measurement and control applications.

Balston brand disposable filter units (DFU) consist of a microfibre filter cartridge permanently bonded into a sealed plastic holder with 125 psig (8.62 barg) pressure ratings, temperatures to 275°F (135°C), and available in low and high flow models. The economical DFU offers all of the advantages of microfibre filter cartridges for high efficiency liquid and gas filtration, combined with the economics and convenience of complete disposability.

Our years of experience in fitting products to individual applications has led to the creation of a variety of standard products that can be ordered off the shelf for general purpose filtration requirements or can be custom designed for all types of specialty applications.

If you do not see the specific configuration, size or material that you are looking for, our OEM engineering team will be happy to review your requirements and design product to your exact specifications.

If you have questions, or would like to place an order, please call 1-800-343-4048.

# Sample Filters

## OEM Disposable Filter Solutions

### General Purpose DFU - Low Flow Gas

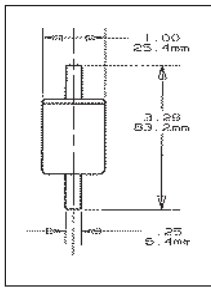

Model 9933-05

#### Specifications

Max. Pressure at 110°F (43°C):	125 psig (8.62 barg)
Max. Temp. at 0 psig:	230°F (110°C)
Inlet / Outlet Ports:	1/4" Tube
Drain:	None
Housing Material of Construction:	Nylon
Internal Volume:	.01L

#### Ordering Information

9933-05-□ Box of 10  
Available in Type Q and in the following grades: A, B, C, BK, and D. Also available with adsorbents 000, 101, 103, and 107.

### General Purpose DFU - Higher Flow

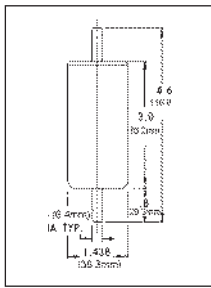

Model 9933-11

#### Specifications

Max. Pressure at 110°F (43°C):	125 psig (8.62 barg)
Max. Temp. at 0 psig:	230°F (110°C)
Inlet / Outlet Ports:	1/4" Tube
Drain:	None
Housing Material of Construction:	Nylon
Internal Volume:	.02L

#### Ordering Information

9933-11-□ Box of 10  
Available in Type Q and in the following grades: A, B, C, and D. Also available with adsorbents 000, 101, 103, and 107.

### General Purpose with Integral Barb Fittings

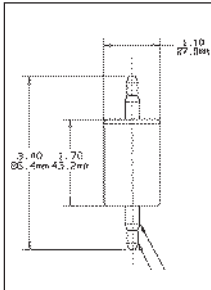

Model 4433-05

#### Specifications

Max. Pressure at 110°F (43°C):	125 psig (8.62 barg)
Max. Temp. at 0 psig:	230°F (110°C)
Inlet / Outlet Ports:	1st Tier: 1/4" Tube 2nd Tier: 3/8" Tube
Drain:	None
Material of Construction:	Nylon
Internal Volume:	.01L

#### Ordering Information

4433-05-□ Box of 10  
Available in Type Q and in grades: A, B, C and D.

### General Purpose with Drain Port

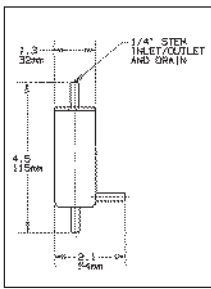

Model 8833-11

#### Specifications

Max. Pressure at 110°F (43°C):	125 psig (8.62 barg)
Max. Temp. at 0 psig:	230°F (110°C)
Inlet / Outlet Ports:	1/4" Tube
Drain:	1/4" Tube
Housing Material of Construction:	Nylon
Internal Volume:	.02L

#### Ordering Information

8833-11-□ Box of 10  
Available in Types Q and X and in the following grades: A, B, C, D, and S.

# Sample Filters

## OEM Disposable Filter Solutions

### High Chemical Resistance - Low Flow

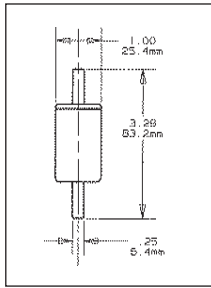

#### Specifications

Max. Pressure at 110°F (43°C): 125 psig (8.62 barg)  
 Max. Temp. at 0 psig: 275°F (135°C)  
 Inlet / Outlet Ports: 1/4" Tube  
 Drain: None  
 Housing Material of Construction: PVDF  
 Internal Volume: .01L

#### Ordering Information

9922-05-□ Box of 10  
 Available in Type Q and in the following grades: A, B, C, D. Also available with adsorbents 000, 101, 103, and 107.

Model 9922-05

### High Chemical Resistance DFU -Higher Flow

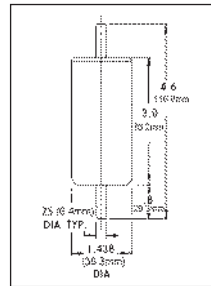

#### Specifications

Max. Pressure at 110°F (43°C): 125 psig (8.62 barg)  
 Max. Temp. at 0 psig: 275°F (135°C)  
 Inlet / Outlet Ports: 1/4" Tube  
 Drain: None  
 Housing Material of Construction: PVDF  
 Internal Volume: .02L

#### Ordering Information

9922-11-□ Box of 10  
 Available in Types Q and in the following grades: A, B, C, and D. Also available with adsorbents 000, 101, 103, and 107.

Model 9922-11

### Oil Indicating DFU

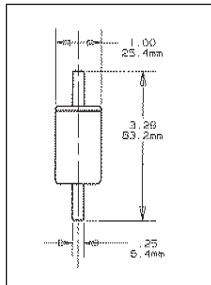

#### Specifications

Max. Pressure at 110°F (43°C): 125 psig (8.62 barg)  
 Max. Temp. at 0 psig: 230°F (110°C)  
 Inlet / Outlet Ports: 1/4" Tube  
 Drain: None  
 Housing Material of Construction: Nylon  
 Internal Volume: .01L

#### Ordering Information

9900-05-□ Box of 10  
 Available in Type K and in grade B.

Model 9900-05

### Large Capacity High Flow DFU

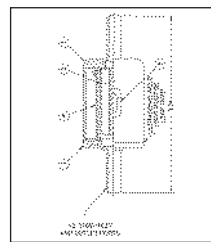

#### Specifications

Max. Pressure at 110°F (43°C): 50 psig (3.4 barg)  
 Max. Temp. at 0 psig: 150°F  
 Inlet / Outlet Ports: 1/2" Tube  
 Drain: None  
 Housing Material of Construction: Nylon  
 Internal Volume: .0138L

#### Ordering Information

8800-12-□ Box of 1  
 Available in Types Q and X and in the following grades: A, B, C, and D. Also available with adsorbents 000, 101, 103, and 107.

Model 8800-12

### Large Capacity High Flow DFU Intake Filter

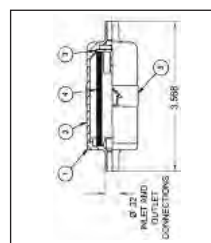

#### Specifications

Max. Pressure at 110°F (43°C): 2 psig (0.14 barg)  
 Max. Temp. at 0 psig: 125°F  
 Inlet / Outlet Ports: .032" OD  
 Drain: None  
 Housing Material of Construction: Polypropylene  
 Internal Volume: 0.033L

#### Ordering Information

9953-11-□ Box of 10  
 Available in Types Q and X and in the following grades: A, B, C, and D.  
 Replacement element:  
 050-11-?Q  
 050-11-?X

Model 9953-11

# Sample Filters

## High Flow Stainless Steel Filter Housings: Moderate to High Pressure Applications

Stainless steel construction

Pressure to 5000 psig (345 barg)

Temperature to 400°F (204°C)

Ideal for high pressure applications

### Models 27/35, 27/80 and 15/80S6

Model 27 housings are among the largest 316 stainless steel filters available with high pressure capability. The 27/35 and 27/80 housings are used when 800 psig rating is required. The 27/35-3000 and 27/80-3000 models are suitable for service up to 3000 psig. The Model 15/80S6 is designed for 2" pipe systems and pressures to 500 psig (35 barg).

### Models 26/35D-3000 and 26/35D-5000

Model 26/35D filter housings are constructed of carbon steel for high pressure applications. The Model 26/35D-3000 is ASME Code stamped at the rated pressure of 3000 psig (207 barg). The Model 26/35D-5000 complies with ASME Code design criteria.



Models 27/35 and 27/80  
(27/35 Shown)



Models 26/35D-3000  
and 26/35D-5000

# Sample Filters

## High Flow Stainless Steel Filter Housings: Moderate to High Pressure Applications

### Principal Specifications

Model	27/35	27/35-3000	27/80	27/80-3000	26/35D-3000,	26/35D-5000	15/80S6
Inlet and Outlet Ports	1" NPT	1" NPT	1" NPT	1" NPT	1" NPT	1" NPT	2" NPT
Drain Port	1/4" NPT	1/4" NPT	1/4" NPT	1/4" NPT	1/4" NPT	1/4" NPT	1/4" NPT
Materials of Construction							
Head	316SS (1)	316SS (1)	316SS (1)	316SS (1)	Carbon Steel	Carbon Steel	Stainless Steel
Bowl	316SS (1)	316SS (1)	316SS (1)	316SS (1)	Carbon Steel	Carbon Steel	Stainless Steel
Internals	316SS (1)	316SS (1)	316SS (1)	316SS (1)	Stainless Steel	Stainless Steel	Stainless Steel
Seals	Viton	Viton	Viton	Viton	Buna-N	Buna-N	Viton
Maximum Temperature	400°F(204°C)	400°F(204°C)	400°F(204°C)	400°F(204°C)	250°F(120°C)	250°F(120°C)	400°F(204°C)
Maximum Pressure	800 psig (55.2 barg) (2)	3000 psig (207 barg) (2)	800 psig (55.2 barg) (2)	3000 psig (207 barg) (2)	3000 psig (207 barg) (3)	5000 psig (345 barg) (3)	800 psig (35 barg) (2)
Shipping Weight	16 lbs (7.3 kg)	25 lbs. (11 kg)	33 lbs. (14.9 kg)	42 lbs. ( 19kg)	80 lbs. (36 kg)(4)	170 lbs.	32 lbs. (14.4 kg)
Dimensions	4.0"D X 16"L (10 cm X 41 cm)	4.3"D X 16"L (11 cm X 41 cm)	4.0"D X 27"L (10 cm X 69 cm)	4.3"D X 27"L (11 cm X 69 cm)	7.0"D X 17"L (18 cm X 93 cm)	8.5"D X 16.25"L	6.3"D X 28"L (16 cm X 71 cm)

Sample Filters

### Ordering Information

For assistance, call toll-free at 1-800-343-4048 8AM to 5PM Eastern Time

Filter Housing Model	27/35	27/35-3000	27/80	27/80-3000	26/35D-3000,	26/35D-5000	15/80S6
Support Core, Required for Liquid Filtration	SS-200-35	SS-200-35	SS-200-80	SS-200-80	Included	Included	SS-200-80
Filter Cartridges	200-35-□	200-35-□	200-80-□	200-80-□	200-35-□	200-35-□	200-80-□
Use only these cartridge types	X, H, Q, CI (5)	X, H, Q, CI (5)	X, H, Q, CI (5)	X, H, Q, CI (5)	X, H, Q, CI(5)	X, H, Q, CI(5)	X,H,Q,CI(5)

### Notes:

1 Constructed of materials which comply with NACE Specification MR-01-75. Request certificate of compliance

2 Maximum pressure ratings are for temperatures to 200°F (93°C). Please consult factory for maximum pressure ratings at elevated temperatures.

3 Vessel is ASME Section VIII, Div. 1 code stamped for rated pressure at 200°F (93°C). For 5000 psig pressure rating without the ASME code stamp, order Model 26/35D-5000.

4 Shipping weight of Model 26/35-5000 is 170 lbs (77kg)

5 To order CI Cartridges, indicate type of adsorbent desired by putting three digit designation after size code. For example, to order a carbon cartridge for Model 27/35 housing, order CI-200-35-000. CI cartridges are sold in boxes of 1.

# Sample Filters

## High Pressure Filter Housings: For High Purity, Low Flow Applications

**Stainless steel construction**

**Pressure to 5000 psig (345 barg)**

**Temperature to 400°F (204°C)**

**Ideal for removing solids and large quantities of liquids from gas**

### Model 85

The Model 85 filter housing is constructed of 316 stainless steel, and has a pressure rating of 5,000 psig (345 barg). This Model can accommodate extended life, X-type filter cartridges and is used when larger quantities of liquids are expected.

### Models 37/12 and 37/25

These T-type filter housings are also constructed of 316 stainless steel, and have a 4000 psig (276 barg) rating. These models are used as sample filters for on-line sample analyzers when a larger line size, higher flow rate, or larger bowl reservoir capacity is required.



Model 85



Models 37/12, 37/25  
(37/25 Shown)

### Principal Specifications

Model	85	37/12	37/25
Inlet and Outlet Ports	1/4" NPT	1/2" NPT	1/2" NPT
Drain Port	1/4" NPT	1/8" NPT	1/8" NPT
Materials of Construction			
Head	316SS (1)	316SS (1)	316SS (1)
Bowl	316SS (1)	316SS (1)	316SS (1)
Internals	316SS (1)	316SS (1)	316SS (1)
Seals	Viton	Viton	Viton
Maximum Temperature	400°F (204°C)	400°F (204°C)	400°F (204°C)
Maximum Pressure	5000 psig (345 barg) (2)	4000 psig (276 barg) (2)	4000 psig (276 barg) (2)
Shipping Weight	4 lbs. (2 kg)	6 lbs. (3 kg)	10 lbs. (5 kg)
Dimensions	2.5"D X 5"L (6cm X 13cm)	2.75"D X 5.75"L (7cm X 14.6cm)	2.75"D X 10.25" L (7cm X 26cm)

### Ordering Information For assistance, call toll-free at 1-800-343-4048 8AM to 5PM Eastern Time

Filter Housing Model	85	37/12	37/25
Support Core, Required for Liquid Filtration	Included	SS-100-12	SS-100-25
Filter Cartridges	050-11-□	100-12-□	100-25-□
Use only these filter cartridge types	X, H, Q	X, H, Q, CI, SMF (3)	X, H, Q, CI (3)

### Notes:

- 1 Constructed of materials which comply with NACE Specification MR-01-75. Request certificate of compliance
- 2 Maximum pressure ratings are for temperatures to 200°F (93°C). Please consult factory for maximum pressure ratings at elevated temperatures.
- 3 To order CI Cartridges, indicate type of adsorbent desired by putting three digit designation after size code. For example, to order a carbon cartridge for Model 27/35 housing, order CI-200-35-000. CI cartridges are sold in boxes of 1.

# Sample Filters

## Stainless Steel Filter Housings: For Liquids with a High Solids Content

Stainless steel construction

Pressure to 425 psig (30 barg)

Temperature to 220°F (104°C)

### Models 33S6 and 45S6

Models 33S6 and 45S6 Filter Housings are constructed of stainless steel and have 1/2" NPT ports. The Model 33S6 uses a 2 1/2" long filter cartridge, and the Model 45S6 uses a 7" long filter cartridge. Both filters are also available with a transparent Pyrex glass bowl (100 psig/7 barg rating) with breakage-protecting external plastic shield.

### Models 33G and 45G

These models offer a transparent Pyrex glass bowl (100 psig rating) with breakage-protecting external plastic shield. They also offer convenient molded gaskets to ensure quick and safe filter change-outs.

### Filter Cartridges

X-type cartridges with integral prefilters are recommended for filtration of all liquids with high solids content, including samples from cooling water, well water, and effluent streams.



Models 33S6 and 45S6  
(45S6 Shown)



Models 33G and 45G  
(45G Shown)

Sample  
Filters

### Principal Specifications

Model	33G	45G	33S6	45S6
Inlet and Outlet Ports	1/2" NPT (1)	1/2" NPT (1)	1/2" NPT (1)	1/2" NPT (1)
Materials of Construction				
Head	316SS	316SS	316SS (5)	316SS (5)
Bowl	Pyrex	Pyrex	316SS (5)	316SS (5)
Internals	316SS	316SS	316SS (5)	316SS (5)
Seals	Viton	Viton	Viton	Viton
Maximum Temperature	160°F (71°C) (2)	160°F (71°C) (2)	400°F (204°C) (3)	400°F (204°C) (3)
Maximum Pressure	100 psig (6.89 barg) (3)	100 psig (6.89 barg) ((3)	425 psig (29.3 barg) ((3)	250 psig (17.24 barg) ((3)
Shipping Weight	3 lbs (1.4 kg)	5 lbs (2.3 kg)	3 lbs (1.4 kg)	5 lbs (2.3 kg)
Dimensions	2.6"D X 4.5"L (6.7cm X 12cm)	2.6"D X 9.3"L (6.7cm X 24cm)	2.6"D X 4.5"L (6.6cm X 11.4cm)	2.6"D X 9"L (6.6cm X 22.9cm)

**Notes:**

1 Also available with 1/4" ports. To order with 1/4" NPT ports, use designation Model 33G-1/4, etc.

2 Limited by maximum temperature of acrylic bowl guards.

3 Maximum pressure ratings are for temperatures to 160°F (71°C). Please consult factory

for maximum pressure ratings at elevated temperatures.

4 Support core for use with X-type cartridges. Flow is outside to inside.

Consult factory for maximum pressure ratings at elevated temperatures.

5 Materials comply with NACE Specification MR-01-75. Request certificate of compliance.

### Ordering Information

For assistance, call toll-free at 1-800-343-4048 8AM to 5PM Eastern Time

Filter Housing Model	33G	45G	33S6	45S6
Filter Cartridge	100-12-□	100-25-□	100-12-□	100-25-□
Use only these				
Filter cartridge types	LP, M, X, CI	LP, X, CI	LP, M, X, CI	LP, X, CI
Support Core (optional) (4)	SS-100-12 (4)	SS-100-25 (4)	SS-100-12 (4)	SS-100-25 (4)

# Sample Filters

## Miniature Filter Housings: Convenient T-type Filters

Stainless steel, PTFE, or Monel construction

Pressure to 5000 psig (345 barg)

T-type construction allows for non-disruptive maintenance

Ideal sample filters for on-line analyzers

### Models 91S6, 95A, 95M, 95S6, 95T, 105S6

These models are miniature T-type filters constructed of 316 stainless steel (5000 psig/345 barg), PTFE (150 psig/10.3 barg), and other specialty materials. With only 19 ml internal volume and the opportunity for by-pass or slipstream filtration using the drain port as an exit port, the model 95 filters are ideal sample filters for on-line analyzers. The model 105S6 has a small internal volume of 15 ml, which is ideal for applications requiring fast sampling response time.



Models 91S6, 95A, 95M, 95S6, 95T (95S6 Shown)



Model 105S6

### Principal Specifications

Model	105S6	91S6	95A	95M	95S6	95T
Inlet and Outlet Ports	1/8" NPT (1)	1/8" NPT (1)	1/8" NPT (1)	1/8" NPT (1)	1/8" NPT (1)	1/8" NPT (1)
Drain Port	1/8" NPT	1/8" NPT	1/8" NPT	1/8" NPT	1/8" NPT	1/8" NPT
Materials of Construction						
Head	316SS (2)	316SS (2)	Aluminum	Monel	316SS (2)	PTFE (2)
Bowl	316SS (2)	316SS (2)	Aluminum	Monel	316SS (2)	PTFE (2)
Internals	316SS (2)	316SS (2)	Aluminum	Teflon	316SS (2)	PTFE (2)
Seals	Viton	Viton	Viton	Viton	Viton	PTFE/Viton
Maximum Temperature	400°F (204°C)	400°F (204°C)	200°F (93°C)	400°F (204°C)	400°F (204°C)	300°F (149°C)
Maximum Pressure	5000 psig (345 barg) (3)	1500 psig (103 barg) (3)	2500 psig (172 barg) (3)	5000 psig (345 barg) (3)	5000 psig (345 barg) (3)	150 psig (10.3 barg) (3)
Shipping Weight	1 lb. (0.4 kg)	1 lb. (0.4 kg)	0.5 lb. (0.2 kg)	1 lb. (0.4 kg)	1 lb. (0.4 kg)	0.5 lb. (0.2 kg)
Dimensions	1.8"D X 3.3"L (4cm X 8cm)	1.5"D X 3.7"L (3.8cm X 9.4cm)	1.8"D X 4"L (4cm X 10cm)	1.8"D X 4"L (4cm X 10cm)	1.8"D X 4"L (4.6cm X 10.2cm)	1.8"D X 4"L (4.6cm X 10.2cm)

### Notes:

1 Also available with 1/4" NPT ports. To order with 1/4" NPT ports, use designation Model 95S6-1/4, etc.

2 Constructed of materials which comply with NACE Specification MR-01-75. Request certificate of compliance.

3 Maximum pressure ratings are for temperatures to 200°F (93°C). Please consult factory for maximum pressure ratings at elevated temperatures.

### Ordering Information For assistance, call toll-free at 1-800-343-4048 8AM to 5PM Eastern Time

Model	105S6	91S6	95A	95M	95S6	95T
Support Core, Required for Liquid Filtration	Included	Included	Included	Included	Included	Included
Filter Cartridges	050-07-□	050-11-□	050-11-□	050-11-□	050-11-□	050-11-□
Use only these filter types	Q, H	Q, H	Q, H	Q, H, M	Q, H, M	Q, H, M



# Sample Filters

## Low Internal Volume Filter Housings: 1/4" and 1/2" Port Size

**Stainless steel construction**

**Pressure to 250 psig (17 barg)**

**Temperature to 400°F (204°C)**

**Compact design**

### Models 91S6, 31S6, 31G, 41S6, 41G

These models offer compact designs and half the dead volume of other sample filters resulting in faster sampling times. They are constructed of stainless steel and available with a variety of seals for easy adaptation to demanding applications. If larger amounts of condensate are expected, specify 33 or 45 series.



Models 31G, 41G  
(41G Shown)



Model 91S6



Models 31S6, 41S6  
(31S6 Shown)

Sample  
Filters

### Principal Specifications

Model	91S6	31G	41G	31S6	41S6
Inlet and Outlet Ports	1/8" NPT (1)	1/2" NPT (1)	1/2" NPT (1)	1/2" NPT (1)	1/2" NPT (1)
Drain Port	1/8" NPT	1/4" NPT	1/4" NPT	1/4" NPT	1/4" NPT
Materials of Construction					
Head	316SS (2)	316SS	316SS	316SS	316SS
Bowl	316SS (2)	Pyrex	Pyrex	316SS	316SS
Internals	316SS (2)	316SS	316SS	316SS	316SS
Seals	Viton	Viton	Viton	Viton	Viton
Maximum Temperature	400°F (204°C)	160°F (71°C)	160°F (71°C)	400°F (204°C)	400°F (204°C)
Maximum Pressure	1500 psig (103 barg) (3)	100 psig (6.9 barg) (3)	100 psig (6.9 barg) (3)	425 psig (29.3 barg) (3)	250 psig (17.2) (3)
Shipping Weight	1 lb. (0.4 kg)	2 lbs (0.9 kg)	4 lbs (1.8 kg)	3 lbs (1.4 kg)	5 lbs (2.3 kg)
Dimensions	1.5"D X 3.7"L (3.8cm X 9.4cm)	2.2"D X 5.5"L (5.7cm X 14cm)	2.2"D X 10.0"L (5.7cm X 26cm)	2.25"D X 5.5"L (5.7cm X 14cm)	2.25"D X 10"L (5.7cm X 25.4cm)

#### Notes:

1 Also available with 1/4" NPT ports. To order with 1/4" NPT ports, use designation Model 31G-1/4 etc.

2 Constructed of materials which comply with NACE Specification MR-01-75. Request certificate of compliance.

3 Maximum pressure ratings are for temperatures to 200°F (104°C). Please consult factory for maximum pressure ratings at elevated temperatures.

### Ordering Information

For assistance, call toll-free at 1-800-343-4048 8AM to 5PM Eastern Time

Filter Housing Model	91S6	31G	41G	31S6	41S6
Support Core, Required for Liquid Filtration	Included	SS-100-12	SS-100-25	SS-100-12	SS-100-25
Filter Cartridges	050-11-□	100-12-□	100-25-□	100-12-□	100-25-□
Use only these Filter cartridge types	Q, H, M	X, H, Q, M	X, H, Q	X, H, Q, M	X, H, Q

# Sample Filters

## High Internal Volume Filter Housings: For Removing Large Volumes of Contaminants

**Stainless steel construction**

**Pressure to 425 psig (30 barg)**

**Temperature to 400°F (204°C)**

**Ideal when a large volume of condensed liquid is expected**

### Models 33S6, 33G, 45S6, 45G

These models are higher flow rate filters. All models are available with 1/4" or 1/2" NPT ports. These filters are also available with clear Pyrex glass bowls (125 psig rating) with breakage protecting external plastic shields. These housings are useful for gas sampling when a large volume of suspended liquid is expected.



**Models 33S6 and 45S6  
(45S6 Shown)**



**Models 33G and 45G  
(45G Shown)**

### Principal Specifications

Model	33G	33S6	45G	45S6
Inlet and Outlet Ports	1/2" NPT (1)	1/2" NPT (1)	1/2" NPT (1)	1/2" NPT (1)
Drain Port	1/8" NPT	1/8" NPT	1/8" NPT	1/8" NPT
Materials of Construction				
Head	316SS	316SS	316SS	316SS
Bowl	Pyrex	316SS	Pyrex	316SS
Internals	316SS	316SS	316SS	316SS
Seals	Viton	Viton	Viton	Viton
Maximum Temperature	160°F (71°C) (2)	400°F (204°C) (3)	160°F (71°C) (2)	400°F (204°C) (3)
Maximum Pressure	125 psig (8.6 barg) (2)	425 psig (30 barg) (2)	125 psig (8.6 barg) (2)	250 psig (17.2 barg) (2)
Shipping Weight	3 lbs./1.4kg	3 lbs./1.4 kg	5 lbs./2.3 kg	5 lbs./2.3 kg
Dimensions	2.6"D X 4.5"L (7cm X 11cm)	2.6"D X 4.5"L (6.6cm X 11.4cm)	2.6"D X 9.3"L (6.6cm X 22.9cm)	2.6"D X 9"L (6.6cm X 22.9cm)

#### Notes:

1 Also available with 1/4" NPT ports. To order with 1/4" NPT ports, use designation Model 33G-1/4, etc.

2 Limited by maximum temperature of acrylic bowl guards.

3 Maximum pressure ratings are for temperatures to 200°F (93°C). Please consult factory for maximum pressure ratings at elevated temperatures.

4 To order CI Cartridges, indicate type of adsorbent desired by putting three digit designation after size code. For example, to order a carbon cartridge for Model 27/35 housing, order CI-200-35-000. CI cartridges are sold in boxes of 1.

### Ordering Information

For assistance, call toll-free at 1-800-343-4048 8AM to 5PM Eastern Time

Model	33G	33S6	45G	45S6
Support Core, Required for Liquid Filtration	SS-100-12	SS-100-12	SS-100-25	SS-100-25
Filter Cartridges	100-12-□	100-12-□	100-25-□	100-25-□
Use only these filter cartridge types	X, H, Q, M, CI	X, H, Q, M, CI	X, H, Q, CI, M	X, H, Q, CI, M

# Sample Filters

## Plastic Filter Housings: 1/4" to 3/4" Line Size

Filter solids and liquids from gases with 99.99% efficiency at 0.01 micron

Liquid filtration efficiency to 1 micron

Temperature to 230°F (110°C)

### Model 90

The Model 90 filter holder is designed to accept grade X or Q type filter cartridges. This model is used as the inlet filter on air, gas or liquid sample analyzers. It can also be used as a vent/breather filter on storage vessels. The disposable filter cartridge is easily replaced in the field, requiring no tools.



Model 90

### Model 58P

The Model 58P housing has a nylon head and internals and a transparent nylon bowl, and replaceable filter cartridges. It is used for filtration of water or mildly acidic or caustic solutions.



Model 58P

### Model 53

The Model 53 housings are constructed of polypropylene, and are designed for a single LP-200 filter cartridge in 5", 10", or 20" lengths. The polypropylene construction provides excellent resistance to non-oxidizing acids, such as HCL in any concentration, sulfuric to 70% concentration, brines, hydrocarbon liquids, alcohols, and concentrated caustic. The Model 53 can be used with certain ketones and chlorinated solvents.



Model 53/18



Models 54/50 and 53/50  
(53/50 Shown)

### Model 54

The Model 54 housings have a polypropylene head and a transparent styrene-acrylonitrile (SAN) bowl. The transparent bowl is available only in the 10" length. Model 54 housings are used for filtration of water or mildly acidic solutions at temperatures below 100°F (38°C).

# Sample Filters

## Plastic Filter Housings: 1/4" to 3/4" Line Size

### Principal Specifications

Model	90	58P	53/18	53/50	54/50
Inlet and Outlet Ports	1/4" Tubing	1/4" NPT	3/8" NPT	3/4" NPT	3/4" NPT
Materials of Construction					
Head	Polyprop.	Nylon	Polyprop.	Polyprop.	Polyprop.
Bowl	Polyprop.	Nylon	Polyprop.	Polyprop.	SAN
Internals	—	Nylon	Polyprop.	Polyprop.	Polyprop.
Seals	—	—	EPR	EPR	EPR
Maximum Temperature	230°F (110°C)	150°F (66°C)	125°F (52°C)	125°F (52°C)	100°F (38°C)
Maximum Pressure	60 psig (4.1 barg) (1)(2)	125 psig (4.1 barg) (1)	125 psig (4.1 barg) (1)	125 psig (4.1 barg) (1)	125 psig (8.6 barg) (1)
Shipping Weight	0.2 lbs. (0.1 kg)	1lbs. (0.5 kg)	3 lbs. (1.4 kg)	4 lbs. (1.8 kg)	4 lbs. (1.8 kg)
Dimensions	1.4"D X 3.8"L (4cm X 10cm)	2.7"D X 6.1"L (7cm X 16cm)	5"D X 6.6"L (11cm X 17cm)	5"D X 12"L (13cm X 30cm)	5"D X 12"L (13cm X 30cm)

#### Notes:

- 1 Maximum pressure ratings are for temperatures to 125°F (52°C). Please consult factory for maximum pressure ratings at elevated temperatures.
- 2 60 psig (4.1 barg) pressure rating with flow direction from inside to out. Consult factory for other operating conditions.

### Ordering Information

For assistance, call toll-free at 1-800-343-4048 8AM to 5PM Eastern Time

Filter Housing	90	58P	53/18	53/50	54/50
Filter Cartridge	100-12-□	LP-100-12-□	LP-200-18-□	LP-200-50-□	LP-200-50-□

# Sample Filters

## Filters for Vehicle Emission Analyzers: Filter System for Gas Engine Analyzers

Complete removal of solid particles,  
condensed water, and oils

Long filter life, even in high use  
conditions

No effect by the filter on the composition  
of the gas

Complete resistance to corrosion

### Model 58N

The Model 58N housing is a rugged, economical housing with a 1/8" NPT drain. The transparent polycarbonate bowl and the nylon head, tie rod, and element retainers are resistant and non-absorbent to all components of the sample stream. The Balston 58N filter housing has much better corrosion resistance and is more economical than other filters used in this application.

The Balston Grade 404 Microfibre Filter Cartridges were developed specifically for use in sample lines to Gasoline Engine Analyzers. The filter cartridges are composed of borosilicate glass and polyolefin fibers. They have a 93% retention efficiency at 0.1 micron and offer a significantly higher solids holding capacity and lower pressure drop than conventional resin-bonded glass microfibre filter cartridges. The Balston Grade 404 filter cartridges are hydrophobic and drain water much more rapidly than all-glass fiber cartridges, greatly reducing the possibility of loss of NO<sub>2</sub> and other water-soluble components from the gas sample.

When installed with inside-to-outside flow direction, the Grade 404 filter cartridges are efficient, fast-draining coalescing filters. When installed with outside-to-inside flow direction, the pure white surface of the filter tube permits quick visual estimation of the dirt loading on the filter cartridge.

In addition to the standard 100-12 size, Grade 404 Microfibre Filter Cartridges are available in sizes to fit all Vehicle Emission Analyzer filter housings.



Model 58N

Model	58N
Inlet and Outlet Ports	1/4" NPT
Drain Port	1/8" NPT
Materials of Construction	
Head	Nylon
Bowl	Polycarbonate
Internals	Nylon
Seals	Buna
Maximum Temperature	150°F (66°C)
Maximum Pressure	10 psig (0.7 barg)
Shipping Weight	1lb. (0.5 kg)
Dimensions	2.8"D X 6.3"L (7cm X 16cm)

Filter Housing Model	58N
Replacement Filter Cartridges (box of 10)	100-12-404
	Note: Filter cartridge not included. Must be ordered separately

# Sample Filters

## Filters for Diesel Engine Analyzers: Remove Impurities from Gas Stream

Totally inorganic filter cartridge is inert and contains no extractables

Temperature capability to 450°F (232°C)

Filter housing designed for convenient external heating

Sample  
Filters

### The Problem:

Diesel engine exhaust has a much higher concentration of suspended solid particles and nonvolatile liquid droplets.

Diesel engine exhaust has a high dew point and must be kept hot to prevent liquid condensation which would affect the accuracy of the analysis. To avoid contamination of sample lines with dirt and oil, most diesel engine analysis systems are designed with the primary filter close to the inlet of the sample system. The filter is externally heated to prevent liquid condensation when the system is started up, but during prolonged operation, the filter often is subjected to engine exhaust gas temperatures, which normally range from 350°F to 450°F (176°C to 232°C) and occasionally get as high as 600°F (315°C).

### The Solution:

Model 38 filters, designed specifically for diesel engine exhaust, are all-stainless steel housings with silicone seals (maximum temperature 600°F/315°C). The 1/4" NPT inlet and outlet ports are located at one end of the cylindrical body, and the bayonet closure for changing the filter cartridge is located at the opposite end. To maintain constant temperature, the body may be wrapped in heating tape or enclosed in an oven. The novel closure design permits an operator wearing gloves to replace a filter element rapidly, without disturbing the heating provisions or gas flow connections. The filter housing may be oriented horizontally, vertically, or at any other convenient attitude.

The standard size Model 38/25 housing has a 10-inch (25 cm) long body. Where the installation requires a smaller size housing, the Model 38/12 with 5 1/2 inch (14 cm) long body is available.



Model 38/12, 38/25  
(38/25 Shown)

The Grade DH21 filter cartridge, composed of borosilicate glass microfibers and inorganic binder, is inert to all components in the gas and stable to 900°F (482°C). The retention efficiency is 93% of 0.1 micron particles and 100% of 2 micron and larger particles. With flow direction through the filter tube inside-to-outside, the internal prefilter in the Grade DH21 cartridge provides satisfactory life in a relatively dirty environment. Since the dirt is trapped on the inside of the cartridge, the external surface of the cartridge and the filter housing remain free of contaminants.

### Principal Specifications

Model	38/12	38/25
Inlet and Outlet Ports	1/4" NPT	1/4" NPT
Materials of Construction		
Head	Stainless Steel	Stainless Steel
Bowl	Stainless Steel	Stainless Steel
Internals	Stainless Steel	Stainless Steel
Seals	Silicone	Silicone
Maximum Temperature	450°F (232°C)	450°F (232°C)
Maximum Pressure	20 PSIG (1.4 barg)	20 PSIG (1.4 barg)
Shipping Weight	5 lbs. (2.3 kg)	4 lbs. (1.8 kg)
Dimensions	2.25"D x 5.5"L (1) (6cm x 14cm)	2.25"D x 10.0"L (1) (6cm x 25cm)

### Ordering Information

Filter Housing Model	Filter Cartridge
38/25 (box of 10) Standard Length	100-25-DH21 (2)
38/12 (box of 10) Short Length	100-12-DH21 (2)

Note: Filter cartridge not included. Must be ordered separately.

#### Notes:

- 1 Dimension without handle. Handle adds 3.75" (9.5 cm).
- 2 If an H-Type filter cartridge is being used, order a modified element retainer kit, P/N 30205.

# Sample Filters

## Series 98 Membrane Filters: Hydrophobic Membrane Protection

Ideal for protecting GCs, Mass Spectrometers, O<sub>2</sub> Analyzers, and Moisture Analyzers

Removes entrained water, submicron sulfuric acid aerosol, and ultra fine particulate

Much lower initial cost and operating costs than other membrane filters



Series 98 Membrane Filter

Sample  
Filters

### Series 98 Membrane Filter

The Series 98 Membrane Filter consists of a housing with a porous membrane filter, which is supported by a sintered porous disk located on the “outlet” side of the housing. Gas enters through the “inlet” port on the upstream side of the membrane, and exits from the “outlet” port on the downstream side. Entrained liquid will not flow through the membrane, and will exit through the “bypass” port on the upstream side of the membrane, completely protecting sensitive instrumentation from moisture. Two models are available: The 98-0 (standard) and the 98-2 (high flow). The 98 Series is identical to other hydrophobic membranes offering the same performance and features but at a much lower price.

### The Membrane

Microscopic pores contained within the membrane permit molecules of gas or vapor to flow through easily, allowing the composition of the sample gas to remain unchanged. Even the smallest liquid molecules remain trapped and are unable to flow through the membrane’s small passages under normal operating conditions. This is due to the high surface tension which causes liquid molecules to bind tightly together to form a group of molecules, moving together, which is too large to fit through the pores of the membrane.

The membrane is extremely inert, and is recommended for most process liquid applications, with the exception of hydrofluoric acid. It is also recommended for use in systems designed for PPB, PPM, and “percent level” component concentrations, as a result of its very low absorption characteristics. The membrane is strong and durable, but also very soft and pliable.

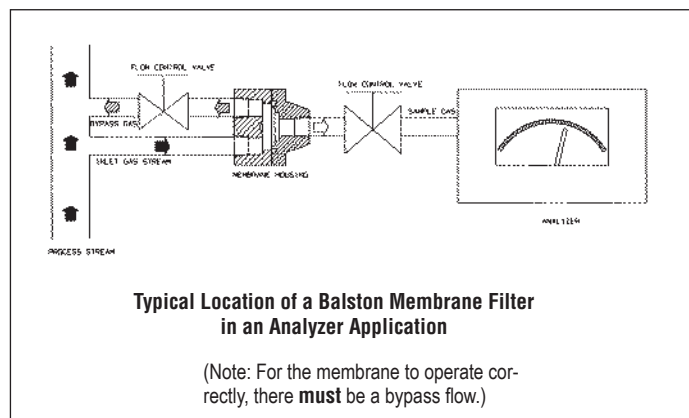

# Sample Filters

## Series 98 Membrane Filters: 1/4" Line Size

### How to Select the Membrane and Model

- Determine the following application requirements:
  - Gas flow rate to the analyzer excluding the bypass flow.
  - Type of suspended liquid to be separated and amount normally present in the sample.
  - Gas sample supply pressure at membrane filter inlet.
- Use Table 1 to select a membrane filter model and membrane type which meet your application requirements. Note that the membrane differential pressure for the model and membrane type selected must be lower than the available gas sample supply pressure.

### Selecting the Appropriate Type of Membrane

There are two basic types of membranes for the 98 Series Membrane Filters: The Model 98-0 (Standard) is suitable for separation of most liquids from gases. The Model 98-2 (High Flow) is best suited for the separation of water and other high surface-tension liquids from gases.

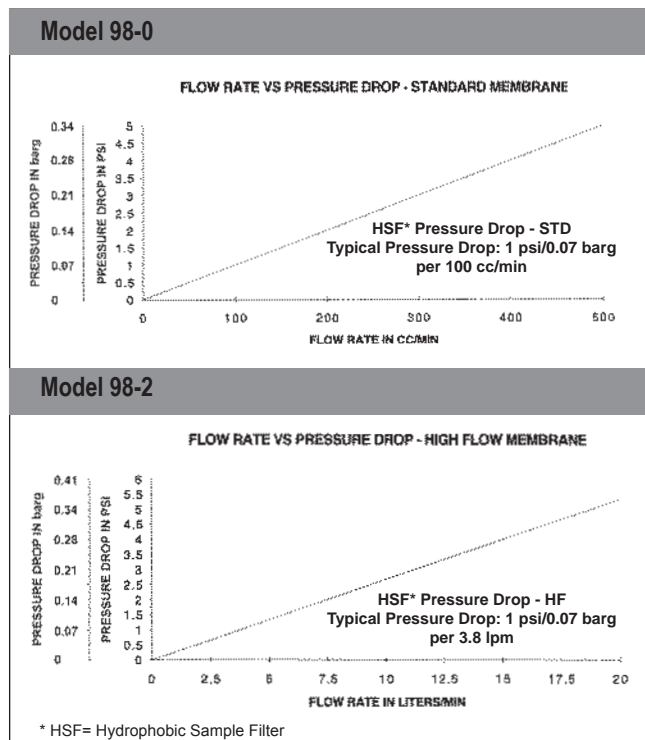

Table 1 Housing and Membrane Selection Guide Principal

Model	98-0	98-2
Membrane Type	Standard (1)	High Flow (2)
Max. Recommended Flow Rate in L/Min.	0.60 (3)	10 (3)
Normal Amount of Liquid Present in Gas	Low to Medium (4)	Low to Medium (4)

**Notes:**

- Standard membrane is suitable for most suspended liquids.
- High flow membrane is suitable for suspended water, solutions consisting primarily of water, sulfuric acid, caustic, glycols, oily liquids, other high surface-tension type liquids.
- Maximum recommended flow rate of gas through the membrane. Does not include the "bypass" flow rate.
- Amount of liquid normally expected to be present in the sample gas: Low: aerosol or occasional droplets. Medium: continuous droplets. High: continuous flowing liquid.

### Specifications

Model	98
Inlet, Outlet, Bypass Ports	1/4" NPT
Materials of Construction	
Housing	316 Stainless Steel (2)
O-rings	Viton (standard)
Kalrez, Buna, EPDM (optional)	
Maximum Operating Pressure	1000 psig @ 200°F (69 barg @ 93°C)
Maximum Temperature	212°F (100°C)
Maximum Flow Rate	
Standard Membrane	.60 L/Min.
High Flow Membrane	10 L/Min.
Typical Membrane Pressure Drop	
Standard Membrane	1 psig (0.07 barg) per 100 cc/min. flow through membrane (1)
High Flow Membrane	1 psig (0.07 barg) per 3.8 liters/min. flow through the membrane (1)
Outside Dimensions	2"D x 2"L (5cm X 5cm)
Shipping Weight	1.5 lbs. (0.7 kg)

**Notes:**

- Pressure Drops are for temperatures to 212°F (100°C).

### Ordering Information

Filter Assembly Maintenance Kits	98-0 (Standard)	98-2 (High Flow)
98014	5 each Membranes & Viton O-Rings for 98-0	
98015	5 each Membranes & Viton O-Rings for 98-2	
98002	5 each Membranes 98-0	
98020	5 each Membranes 98-2	



# Sample Filters

## Series A98 Coalescer Membrane Combination Filters

**A98 Series offers continuous coalescing of all liquid and the security of hydrophobic membrane protection all in one unit**

**Fewer fittings required - reducing risk of leaks**

**More compact - no need for separate coalescers**

**Less maintenance and downtime as the membrane is fully protected from solids & liquids**

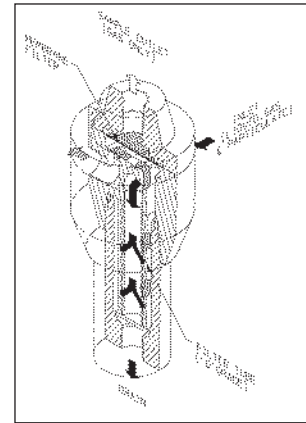

**Series A98 Coalescer Membrane Combination Filter**

### Series A98 Coalescer Membrane Combination Filter

The Balston Coalescer Membrane Combination Filter is designed to remove entrained liquid and particulate in gas samples for a wide variety of applications, and thereby prevents contamination or damage to the analyzers and sample system components. Typically located upstream from the analyzer or component it is protecting, the Coalescer Membrane Combination provides protection even if other sample system components fail.

The Coalescer Membrane Combination offers the performance and protection of the 98 Series Membrane Filter with the additional benefits of coalescing liquids and entrapment of particulates, offering maximum protection of the membrane. There is no need for prefiltration which places more volume in the sample system, and requires more space for installation and more potential for leaks.

The Series A98 consists of a housing with a porous membrane filter, which is supported by a sintered porous disk located on the “outlet” side of the housing. Gas enters through the “inlet” port and is directed down through the coalescing filter. The coalescer traps all particulates and continuously drains liquid contaminants. The sample gas then flows upward to the upstream side of the membrane, and exits from the “outlet” port on the downstream side. Entrained liquid will not flow through the membrane, and will exit through the drain port on the downstream side of the coalescer.

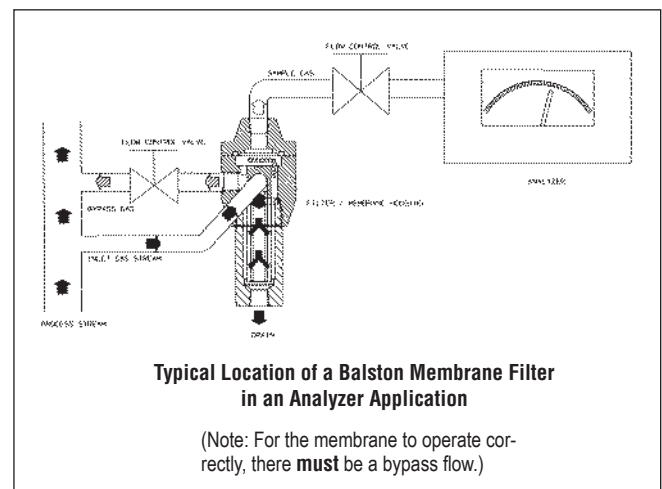

### The Membrane

Microscopic pores contained within the membrane permit molecules of gas or vapor to flow through easily, allowing the composition of the sample gas to remain unchanged. Even the smallest liquid molecules remain trapped and are unable to flow through the membrane’s small passages under normal operating conditions. This is due to the high surface tension which causes liquid molecules to bind tightly together to form a group of molecules, moving together, which is too large to fit through the pores of the membrane.

The membrane is extremely inert, and is recommended for most process liquid applications, with the exception of hydrofluoric acid. It is also recommended for use in systems designed for PPB, PPM, and “percent level” component concentrations, as a result of its very low absorption characteristics. The membrane is strong and durable, but also very soft and pliable.

# Sample Filters

## A98/11 Series Coalescer: Membrane Combination Filter

### How to Select the Membrane and Model

- Determine the following application requirements:
  - Gas flow rate to the analyzer excluding the bypass flow.
  - Type of suspended liquid to be separated and amount normally present in the sample.
  - Gas sample supply pressure at Membrane Filter inlet.
- Use Table 1 to select a Membrane Filter model and Membrane type which meet your application requirements. Note that the membrane differential pressure for the model and membrane type selected must be lower than the available gas sample supply pressure.

### Selecting the Appropriate Type of Membrane

There are two basic types of membranes for the A98/11 Series Membrane Filters: The Model A98/11-\_\_Q-0 (Standard) is suitable for separation of most liquids from gases. The Model A98/11-\_\_Q-2 (High Flow) is best suited for the separation of water and other high surface-tension liquids from gases.

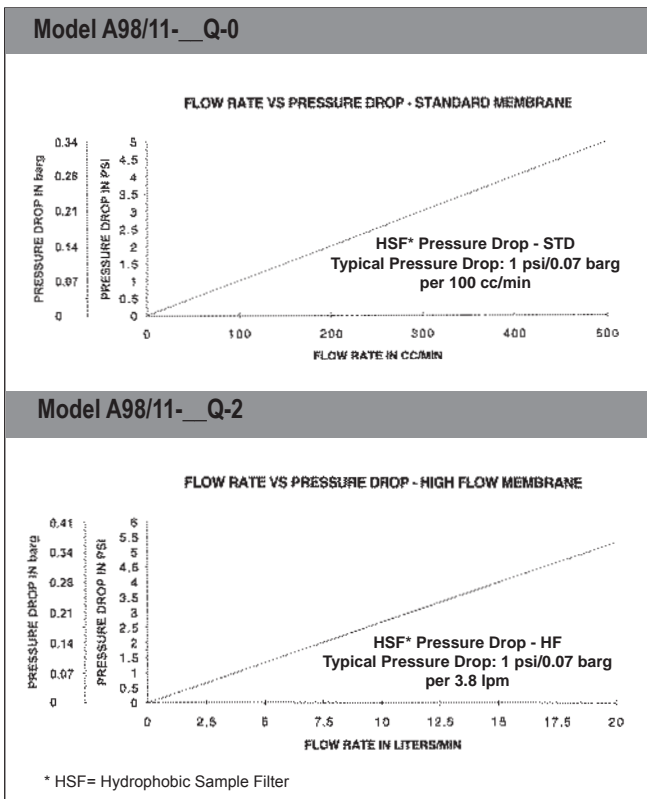

Table 1 Housing and Membrane Selection Guide

Model	A98/11-__Q-0	A98/11-__Q-2
Membrane Type	Standard (1)	High Flow (2)
Max. Recommended Flow Rate in L/Min.	0.60 (3)	10 (3)
Normal Amount of Liquid Present in Gas	Low to Medium (4)	Low to Medium (4)

#### Notes:

- Standard membrane is suitable for most suspended liquids.
- High flow membrane is suitable for suspended water, solutions consisting primarily of water, sulfuric acid, caustic, glycols, oily liquids, other high surface-tension type liquids.
- Maximum recommended flow rate of gas through the membrane. Does not include the "bypass" flow rate.
- Amount of liquid normally expected to be present in the sample gas: Low: aerosol or occasional droplets. Medium: continuous droplets. High: continuous flowing liquid.

### Principal Specifications

Model	A98/11- [ ] Q - [ ]
Inlet, Outlet, Bypass Ports	1/4" NPT
Materials of Construction	
Housing	316 Stainless Steel
O-rings	Viton (standard)
Kalrez, Buna, EPDM (optional)	
Maximum Operating Pressure	1000 psig @ 200°F (69 barg @ 93°C)
Maximum Temperature	212°F (100°C)
Maximum Flow Rate	
Standard Membrane	.60 L/Min.
High Flow Membrane	10 L/Min.
Typical Membrane Pressure Drop	
Standard Membrane	1 psig (0.07 barg) per 100 cc/min. flow through membrane (1)
High Flow Membrane	1 psig (0.07 barg) per 3.8 liters/min. flow through the membrane (1)
Outside Dimensions	2"D x 4"L (5cm X 10cm)
Shipping Weight	2.4 lbs. (1.1 kg)

#### Notes:

- Pressure Drops are for temperatures to 212°F (100°C).
- Constructed of materials which comply with NACE Specification MR-01-75. Request certificate of compliance.

### Ordering Information

Filter/Membrane Replacement Kits	A98/11-__Q-0 A98/11-__Q-2
98011	5 ea. DQ Filters, Viton O-Rings and Membranes for A98/11-DQ-O
98012	5 ea. BQ Filters, Viton O-Rings and Membranes for A98/11-BQ-2
98013	5 ea. DQ Filters, Viton O-Rings and Membranes for A98/11-DQ-2
98010	5 ea. BQ Filters, Viton O-Rings and Membranes for A98/11-BQ-O
98002	5 ea. Membranes for A98-0 or A98/11_Q-0
98020	5 ea. Membranes for A98-2 or A98/11_Q-2
050-11-__Q	10 ea. Coalescing Filter Cartridges

# Sample Filters

## A39/12 Series Coalescer: Membrane Combination Filter

The A39/12 Series offers continuous coalescing of all liquid and the security of hydrophobic membrane protection all in one unit

Fewer fittings required - reducing risk of leaks

More compact - no need for separate coalescers

Less maintenance and downtime as the membrane is fully protected from solids & liquids

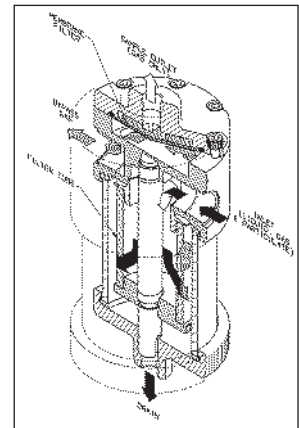

Series A39/12 Coalescer Membrane Combination Filter

Sample Filters

### Series A39/12 Coalescer Membrane Combination Filter

The Balston Coalescer Membrane Combination Filter is designed to remove entrained liquid and particulate in gas samples for a wide variety of applications, and thereby prevents contamination or damage to the analyzers and sample system components. Typically located upstream from the analyzer or component it is protecting, the Coalescer Membrane Combination provides protection even if other sample system components fail.

The Coalescer Membrane Combination offers the performance and protection of the A39/12 Series Membrane Filter with the additional benefits of coalescing liquids and entrapment of particulates, offering maximum protection of the membrane. There is no need for prefiltration which places more volume in the sample system, and requires more space for installation and more potential for leaks.

The A39/12 Series consists of a housing with a porous membrane filter, which is supported by a sintered porous disk located on the "outlet" side of the housing. Gas enters through the "inlet" port and is directed down through the coalescing filter. The coalescer traps all particulates and continuously drains liquid contaminants. The sample gas then flows upward to the upstream side of the membrane, and exits from the "outlet" port on the downstream side. Entrained liquid will not flow through the membrane, and will exit through the drain port on the downstream side of the coalescer.

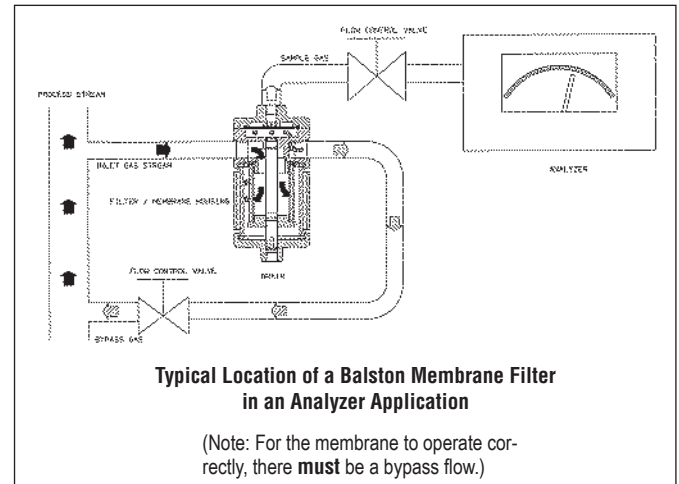

### The Membrane

Microscopic pores contained within the membrane permit molecules of gas or vapor to flow through easily, allowing the composition of the sample gas to remain unchanged. Even the smallest liquid molecules remain trapped and are unable to flow through the membrane's small passages under normal operating conditions. This is due to the high surface tension which causes liquid molecules to bind tightly together to form a group of molecules, moving together, which is too large to fit through the pores of the membrane.

The membrane is extremely inert, and is recommended for most process liquid applications, with the exception of hydrofluoric acid. It is also recommended for use in systems designed for PPB, PPM, and "percent level" component concentrations, as a result of its very low absorption characteristics. The membrane is strong and durable, but also very soft and pliable.

# Sample Filters

## A39/12 Series Coalescer: Membrane Combination Filters

### How to Select the Membrane and Model

- Determine the following application requirements:
  - Gas flow rate to the analyzer excluding the bypass flow.
  - Type of suspended liquid to be separated and amount normally present in the sample.
  - Gas sample supply pressure at Membrane Filter inlet.
- Use Table 1 to select a Membrane Filter model and Membrane type which meet your application requirements. Note that the membrane differential pressure for the model and membrane type selected must be lower than the available gas sample supply pressure.

### Selecting the Appropriate Type of Membrane

There are two basic types of membranes for the A39/12 Series Membrane Filters: The Model A39/12-0 (Standard) is suitable for separation of most liquids from gases. The Model A39/12-2 (High Flow) is best suited for the separation of water and other high surface-tension liquids from gases. A Pyrex bowl is available which offers full visibility of coalescing chamber.

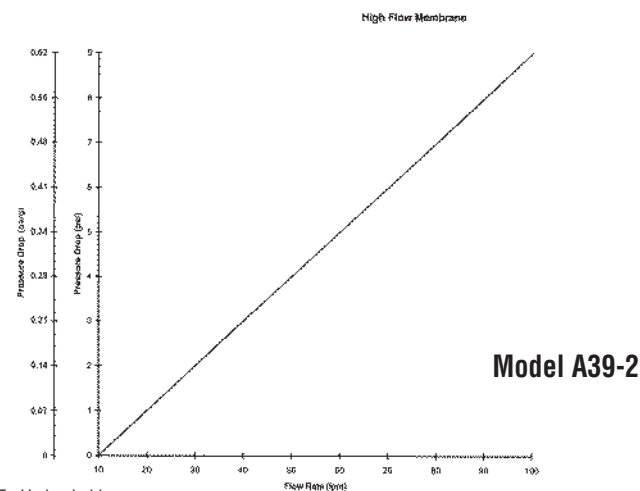
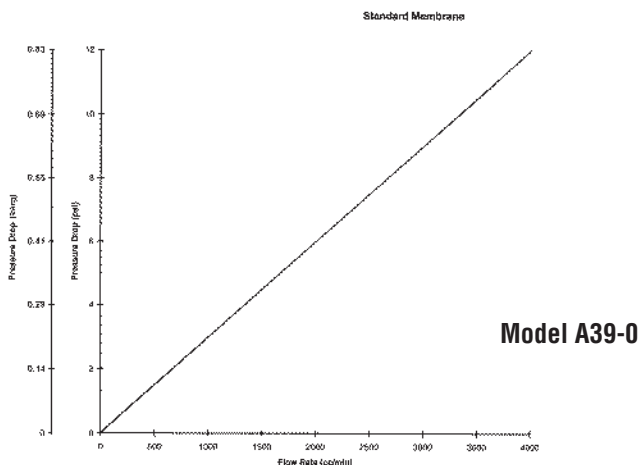

\* HSF= Hydrophobic Sample Filter

Table 1 Housing and Membrane Selection Guide

Model	A39-0 Series	A39-2 Series
Membrane Type	Standard (1)	High Flow (2)
Max. Recommended Flow Rate in L/Min.	1.0 lpm (3)	70 lpm (3)
Normal Amount of Liquid Present in Gas	Low to Medium (4)	Low to Medium (4)

**Notes:**

- Standard membrane is suitable for most suspended liquids.
- High flow membrane is suitable for suspended water, solutions consisting primarily of water, sulfuric acid, caustic, glycols, oily liquids, other high surface-tension type liquids.
- Maximum recommended flow rate of gas through the membrane. Does not include the "bypass" flow rate.
- Amount of liquid normally expected to be present in the sample gas: Low: aerosol or occasional droplets. Medium: continuous droplets. High: continuous flowing liquid.

### Principal Specifications

Model	A39/12 Series
Bypass Ports	1/2" NPT
Sample Port	1/4" NPT
Materials of Construction	
Housing	316 Stainless Steel (2)
O-rings	Viton (standard) Kalrez, Buna, EPDM (optional)
Maximum Operating Pressure	425 psig/29.3 barg @ 200°F/93°C (100 psig/6.9 barg @ 200°F/ 93°C with Pyrex bowl)
Maximum Temperature	212°F (100°C)
Maximum Flow Rate	
Standard Membrane	1 L/Min.
High Flow Membrane	70 L/Min.
Typical Membrane Pressure Drop	
Standard Membrane	1 psig (0.07 barg) per 250 cc/min. flow through membrane (1)
High Flow Membrane	1 psig (0.07 barg) per 20 liters/min. flow through the membrane (1)
Outside Dimensions	3.3"D x 7.3"L (8.4 cm X 18.5 cm)
Shipping Weight	7 lbs. (1.1 kg)

**Notes:**

- Pressure Drops are for temperatures to 212°F (100°C).
- Constructed of materials which comply with NACE Specification MR-01-75. Request certificate of compliance.

### Ordering Information

Filter/Membrane Replacement Kits	A39/12-__X-0, A39/12-__X-2
39014	5 ea. Viton O-Rings and Membranes for A39/12-0
39015	5 ea. Viton O-Rings and Membranes for A39/12-2
39002	5 ea. Membranes for A39/12-0
39020	5 ea. Membranes for A39/12-2
150-12-__X	10 ea. Coalescing Filter Cartridges

**Notes:**

- For Glass Bowl version order: A39/12G-\_\_X-(0)-(2)

# Sample Filters

## 39 Series Membrane Filters

Ideal for protecting GCs, Mass Spectrometers, O<sub>2</sub> Analyzers, and Moisture Analyzers

Removes entrained water, submicron sulfuric acid aerosol, and ultra fine particulate

Much lower initial cost and operating costs than other membrane filters



39 Series

Sample  
Filters

### The 39 Series Membrane Filter

The 39 Series Membrane Filter consists of a housing with a porous membrane filter, which is supported by a sintered porous disk located on the “outlet” side of the housing. Gas enters through the “inlet” port on the upstream side of the membrane, and exits from the “outlet” port on the downstream side. Entrained liquid will not flow through the membrane, and will exit through the “bypass” port on the upstream side of the membrane, completely protecting sensitive instrumentation from moisture. Two models are available: The 39-0 (standard) and the 39-2 (high flow). The 39 Series is identical to other hydrophobic membranes offering the same performance and features but at a much lower price.

### The Membrane

Microscopic pores contained within the membrane permit molecules of gas or vapor to flow through easily, allowing the composition of the sample gas to remain unchanged. Even the smallest liquid molecules remain trapped and are unable to flow through the membrane’s small passages under normal operating conditions. This is due to the high surface tension which causes liquid molecules to bind tightly together to form a group of molecules, moving together, which is too large to fit through the pores of the membrane.

The membrane is extremely inert, and is recommended for most process liquid applications, with the exception of hydrofluoric acid. It is also recommended for use in systems designed for PPB, PPM, and “percent level” component concentrations, as a result of its very low absorption characteristics. The membrane is strong and durable, but also very soft and pliable.

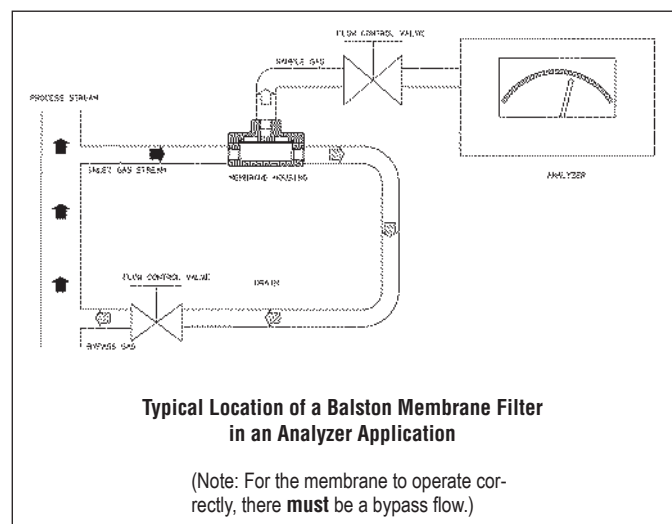

# Sample Filters

## 39 Series Membrane Filters: 1/4" Line Size

### How to Select the Membrane and Model

- Determine the following application requirements:
  - Gas flow rate to the analyzer excluding the bypass flow.
  - Type of suspended liquid to be separated and amount normally present in the sample.
  - Gas sample supply pressure at membrane filter inlet.
- Use Table 1 to select a membrane filter model and membrane type which meet your application requirements. Note that the membrane differential pressure for the model and membrane type selected must be lower than the available gas sample supply pressure.

### Selecting the Appropriate Type of Membrane

There are two basic types of membranes for the 39-2 Series Membrane Filters: The Model 39-0 (Standard) is suitable for separation of most liquids from gases. The Model 39-2 (High Flow) is best suited for the separation of water and other high surface-tension liquids from gases.

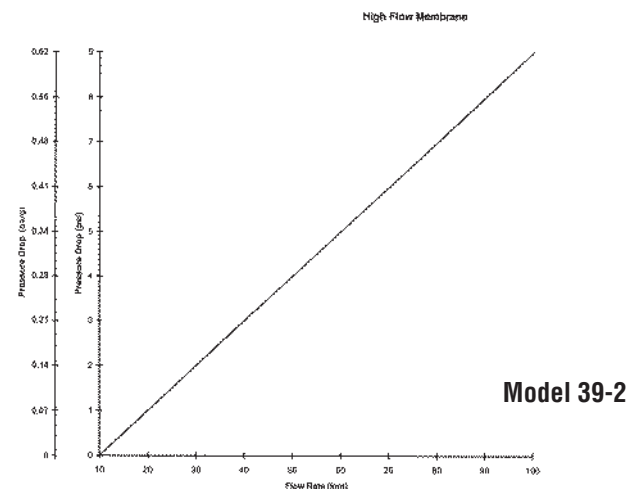
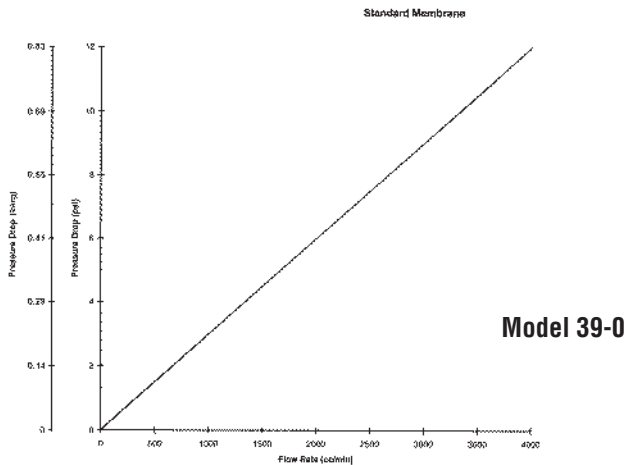

**Table 1 Housing and Membrane Selection Guide**

Model	39-0	39-2 Series
Membrane Type	Standard (1)	High Flow (2)
Max. Recommended Flow Rate in L/Min.	0.04 scfm (1.0 lpm) (3)	2.5 scfm (70 lpm) (3)
Normal Amount of Liquid Present in Gas	Low to Medium (4)	Low to Medium (4)

**Notes:**

- Standard membrane is suitable for most suspended liquids.
- High flow membrane is suitable for suspended water, solutions consisting primarily of water, sulfuric acid, caustic, glycols, oily liquids, other high surface-tension type liquids.
- Maximum recommended flow rate of gas through the membrane. Does not include the "bypass" flow rate.
- Amount of liquid normally expected to be present in the sample gas: Low: aerosol or occasional droplets. Medium: continuous droplets. High: continuous flowing liquid.

### Principal Specifications

Model	39 Series
Bypass Ports	1/2" NPT
Sample Port	1/4" NPT
Materials of Construction	
Housing	316 Stainless Steel (2)
O-rings	Viton (standard) Kalrez, Buna, EPDM (optional)
Maximum Operating Pressure	500 psig (35 barg) @ 200°F (93°C) (100 psig (6.9 barg) @ 200°F (93°C) with Pyrex bowl)
Maximum Temperature	212°F (100°C)
Maximum Flow Rate	
Standard Membrane	0.04 scfm (1 L/Min.)
High Flow Membrane	2.5 scfm (70 L/Min.)
Typical Membrane Pressure Drop	
Standard Membrane	1 psig (0.07 barg) per 250 cc/min. flow through membrane (1)
High Flow Membrane	1 psig (0.07 barg) per 20 liters/min. flow through the membrane (1)
Outside Dimensions	3.3"D x 2"L (8.4cm X 5.1cm)
Shipping Weight	3 lbs. (1.4 kg)

**Notes:**

- Pressure Drops are for temperatures to 212°F (100°C).
- Constructed of materials which comply with NACE Specification MR-01-75. Request certificate of compliance.

### Ordering Information

Filter/Membrane Replacement Kits	39-0, 39-2
39014	5 ea. Viton O-Rings and Membranes for 39-0
39015	5 ea. Viton O-Rings and Membranes for 39-2
39002	5 ea. Membranes for 39-0
39020	5 ea. Membranes for 39-2

Sample Filters

# Sample Filters

## Fast Loop Filters: Filtration Efficiency from 100 $\mu$ m to 0.01 $\mu$ m

All 316 Stainless steel/Pyrex construction

Accepts Balston disposable microfibre filter cartridge and stainless steel cartridge

Compact design for fast response time

Process stream inlet/outlet ports and sample flow ports are identical, eliminating backup pressure in the system



Model 41GCFL-1/4

### Description

Balston fast loop filters are constructed of 316 stainless steel with an optional stainless steel bowl or pyrex bowl. This flow through design continuously flushes the filter cartridge carrying the contaminants back out to the process stream, thus maximizing the filter cartridge life. The low flow sample stream pulled into the analyzer is filtered to ranges of 100 micron to 0.01 micron (depending on the filtration efficiency required). Two designs are available. The T-type design is suitable for high flow, high volume applications. The In-line design is ideal for heavily contaminated applications.

### Operation

Axial velocity flushes the bulk contaminants through the filter housing back to the process stream. The sample stream passes through the filter cartridge wall with low flow and radial velocity. The clean side of the sample filter system has very low volume which minimizes lag time. A four to one flow rate is recommended to realize the benefits of prolonged filter cartridge life associated with continuous flushing.



Model 48S6



Model 49S6

# Sample Filters

## Fast Loop Filters: Filtration Efficiency from 100µm to 0.01µm

### Principal Specifications

Model	31GCFL-1/4	31S6CFL-1/4	41GCFL-1/4	41S6CFL-1/4	48S6	49S6
Inlet and Outlet Ports	1/4" NPT	1/4" NPT	1/4" NPT	1/4" NPT	1/4" NPT	1/2" NPT
Drain Port	1/4" NPT	1/4" NPT	1/4" NPT	1/4" NPT	—	—
Materials of Construction						
Head	316 SS	316 SS (2) 316 SS	316 SS (2)	316 SS (2)	316 SS (2)	
Bowl	Pyrex (1)	316SS (1)(2)	Pyrex (1)	316 SS (1)(2)	316 SS (1)(2)	316 SS (1)(2)
Internals	316SS	316 SS (2) 316 SS	316 SS (2)	316 SS (2)	316 SS (2)	
Seals	Viton	Viton Viton	Viton	Viton	Viton	
Maximum Temperature	160°F (71°C)	400°F (204°C)	160°F (71°C)	400°F (204°C)	400°F (204°C)	400°F (204°C)
Maximum Pressure	100 psig (7 barg) (2)	425 psig (30 barg) (2)	100 psig (7 barg) (2)	250 psig (17 barg) (2)	5,000 psig (345 barg) (2)	1,500 psig (100 barg) (1)
Shipping Weight	2 lbs (0.9 kg)	3 lbs (1.4 kg)	4 lbs (1.8 kg)	5 lbs (2.3 kg)	1.1 lbs (0.2 kg)	2.5 lbs (0.4 kg)
Dimensions	2.2"D x 5.5"L (5.7cm x 14cm)	2.2"D x 5.5"L (5.7cm x 14cm)	2.2"D x 10"L (5.7cm x 25cm)	2.2"D x 10"L (5.7cm x 25cm)	1.35"D x 4"L (3.2cm x 10cm)	1.9"D x 7"L (4.8cm x 17.8cm)

#### Notes:

1 Maximum pressure ratings are for temperatures to 200°F (104°C). Please consult factory for maximum pressure ratings at elevated temperatures.

2 Constructed of materials which comply with NACE Specification MR-01-75. Request certificate of compliance.

### Ordering Information

For Assistance, call toll-free at 1-800-343-4048 8AM to 5PM Eastern Time

Filter Housing Model	31GCFL-1/4	31S6CFL-1/4	41GCFL-1/4	41S6CFL-1/4	48S6	49S6
Support Core, Required for Liquid Filtration	SS-100-12	SS-100-12	SS-100-25	SS-100-25	Included	----
Filter Cartridges	100-12-□	100-12-□	100-25-□	100-25-□	050-11-□	100-185-□
Use only these Filter types	X, H, Q, M	X, H, Q, M	X, H, Q, M	X, H, Q, M	X, H, Q, M	X, H, Q



# Sample Filters

## Horizontally Mounted Sample Filter: Minimal Panel Space Required

Horizontal mounting minimizes space requirement on panel

All connections are made to the head eliminating the need to break the lines for filter changeouts

The only filter available that is mounted at an angle to ensure complete removal of all liquids

Includes cadmium plated steel mounting bracket



Model 47S6

Sample  
Filters

### Model 47S6

The Model 47S6 is designed to filter particulates and liquids from a gas sample, protecting on-line process analyzers from contamination. This unique design allows the filter to be mounted horizontally which minimizes the amount of space taken up on the panel.

It is also angled at 10° which ensures all collected liquids drain back to the drain port and not carried downstream to the analyzer. The drain port is drilled and tapped at an opposing angle eliminating the need to bend tubing.

Additionally, all connections (including the drain connection) are made to the head which eliminates the need to break the lines for filter changeouts.

This is an ideal filter for those applications requiring high efficiency filtration with the need for convenient filter changes on crowded panels.

### Principal Specifications

Model	47S6
Inlet and Outlet Ports	1/4" NPT
Drain Port	1/4" NPT
Materials of Construction	316 SS (2)
Seals	Viton
Maximum Temperature	400°F (204°C)
Maximum Pressure	1500 psig (100 barg) (1)
Shipping Weight	1lb. (0.4 kg)
Dimensions	1.5"D X 3.7"L (4cm X 9cm)

### Ordering Information

Filter Housing Model	47S6
Filter Cartridges	050-11-□
Use only these filter types	Q, H
Support Core required for liquid filtration	Included

#### Notes:

- 1 1500 psig @ 200°F (100 barg @90°C) consult factory for pressure ratings at elevated temperatures.
- 2 Constructed of materials which comply with NACE Specification MR-01-75. Request certificate of compliance.

## Application Notes

# Vacuum Pump Inlet & Exhaust Filters

## Balston Vacuum Pump Filters

Balston Vacuum Pump Exhaust Filters remove 99.9% of 0.1 micron oil mist and smoke particles. Balston Grade 30 Vacuum Pump Inlet Filters remove 90% of all 0.1 micron particles and droplets. Balston Grade 102 Vacuum Pump Inlet Filters prevent oil backstreaming from the pump to the evacuated chamber, and protect the pump from damage by submicron particles (at relatively low concentrations).

All Balston filters are available for hazardous and non-hazardous applications, and offer superior chemical and solvent resistance. Balston Vacuum Pump Filters increase productivity by eliminating costly shutdown time and maintenance.



## Product Features

- Exhaust filters eliminate oil mist and smoke from vacuum pump exhaust
- Prevent oil backstreaming
- Prevent oil accumulation in ductwork
- Protect vacuum pumps and reduce costly maintenance
- Easy to install and maintain

Small Scale Laboratory Vacuum Pumps



Specialized Vacuum Electronics Manufacturing

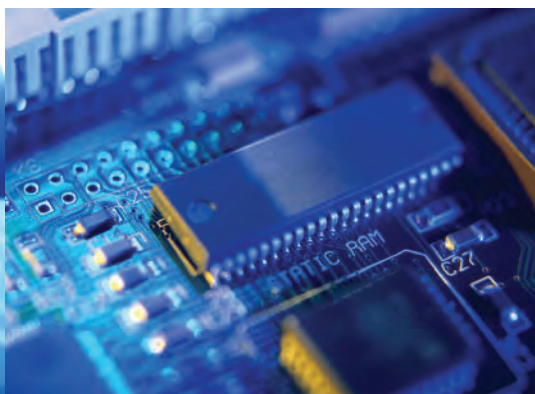

High Volume Vacuum for Process Packaging



# Vacuum Pump Inlet & Exhaust Filters

## Exhaust Filters for Hazardous/Corrosive Applications

Eliminate 99.9% oil mist and smoke from vacuum pump exhaust

Prevent oil accumulation in ductwork

Recover expensive lubricating oils, and automatically return filtered oil to pump

Eliminate potential OSHA and EPA violations



CV-0118

Vacuum  
Pump Filters

### Balston Vacuum Pump Exhaust Filters

Balston Vacuum Pump Exhaust Filters remove all visible oil mist and smoke from vacuum pump exhaust, even when it is saturated with oil. The high efficiency filter cartridge continuously drains the collected liquid, allowing the user to recover expensive lubricating fluid.

#### How To Select The Filter

For most applications, simply select the filter assembly which has a flow capacity equal to or greater than the vacuum pump exhaust flow output (see chart on the next page). The Filter Assemblies are shipped with filter cartridges, and final filter pad. Optional adaptors are available for KF and NW connections.

Filter Selection Chart (for hazardous/corrosive applications)

Max. Pump Flow Rate (CFM)	Recommended Filter Model Number
3 (5 m <sup>3</sup> /h)	CV-0112-371H
9 (15 m <sup>3</sup> /h)	CV-0118-371H

# Vacuum Pump Inlet & Exhaust Filters

## Exhaust Filters for Hazardous/Corrosive Applications

### Principal Specifications

Model	CV-0112-371H	CV-0118-371H
Port Size	1/2" NPT	3/4" NPT
Max. Flow Rate	3 CFM	9 CFM
Materials of Construction		
Head	—	—
Bowl	304 SS	304 SS
Internals	304 SS	304 SS
Seals	None	None
Maximum Temperature	250°F (121°C)	250°F (121°C)
Maximum Pressure	15 psig (1.0 barg)	15 psig (1.0 barg)
Shipping Weight	0.5 lbs. (0.2 kg)	0.8 lbs. (0.4 kg)
Dimensions	2.9"Dia. X 4.2"H (7cm X 11cm)	4.0"Dia. X 5.3"H (10cm X 13cm)

### Ordering Information

For assistance, call toll-free at 1-800-343-4048 8AM to 5PM Eastern Time

Model	CV-0112-371H (1)	CV-0118-371H (1)
Number of Filter Cartridges Required	—	—
Replacement Filter Cartridges		
Box of 3	—	—
Box of 7	—	—
Box of 10	—	—
Number of Pressure Relief Retainers #20222	—	—
Optional Accessories:	#11015 Back Pressure Gage, Stainless Steel, 0-15 psi (0-1.0 barg) rating, 1/4" NPT fitting. Vacuum Pump-to-Filter Adaptors: Please refer to Pages 141 - 142.	

#### Notes:

1 Filter cartridge is permanently sealed into housing. The entire unit is disposable. Pressure relief filter tube retainer not available in these models.

# Vacuum Pump Inlet & Exhaust Filters

## Exhaust Filters for Non-Hazardous/Non-Corrosive Applications

Eliminate 99.9% oil mist and smoke from vacuum pump exhaust

Prevent oil accumulation in ductwork

Recover expensive lubricating oils, and automatically return filtered oil to pump

Eliminate potential OSHA and EPA violations

### Balston Vacuum Pump Exhaust Filters

Balston Vacuum Pump Exhaust Filters remove all visible oil mist and smoke from vacuum pump exhaust, even when it is saturated with oil. The high efficiency filter cartridge continuously drains the collected liquid, allowing the user to recover expensive lubricating fluid. Filters are available for pumps with flow ratings ranging from 3 to 850 cfm (5-1440 m<sup>3</sup>/h).

### How To Select The Filter

For most applications, simply select the filter assembly which has a flow capacity equal to or greater than the vacuum pump exhaust flow output (see chart below). The filter assemblies are shipped with filter cartridges, pressure gage (20 cfm and larger), and final filter pad. Optional adaptors are available for KF and NW connections.

### Filter Selection Chart

(for non-hazardous/non-corrosive applications)

Max. Pump Flow Rate (CFM/m <sup>3</sup> /h)	Recommended Filter Model Number
3 (5)	9955-12-371H, 9956-12-371H
9 (15)	AR-009-371H
15 (25)	AR-015-371H
20 (34)	AR-0316-371H
43 (73)	AR-0335-371H
100 (170)	AR-0735-371H
200 (340)	AR-0780-371H
300 (510)	AR-1280-371H
450 (765)	AR-1680-371H
850 (1440)	AR-3080-371H



Model 9955-12



Model AR-009



Model AR-0316



Model AR-0780



Model AR-3080

# Vacuum Pump Inlet & Exhaust Filters

## Exhaust Filters for Non-Hazardous/Non-Corrosive Applications

### Principal Specifications

Model	Port Size	Max. Flow Rate	Materials of Construction				Max. Temp.	Max. Press.	Shipping Wt.	Dimensions
			Head	Bowl	Internals	Seals				
9955-12-371H	1/2"NPT	3CFM	—	Nylon	Nylon	None	250°F(121°C)	15PSIG(1.0barg)	.25lbs(0.1kg)	2"Dia.X3.7"H
9956-12-371H	KF-16	3CFM	—	Nylon	Nylon	None	250°F(121°C)	15PSIG(1.0barg)	.25lbs(0.1kg)	2"Dia.X3.7"H
AR-009-371H	3/4"NPT	9CFM	Aluminum	Aluminum	Alum./SS/Nylon	Viton	300°F(149°C)	15PSIG(1.0barg)	1.0lbs(0.45kg)	3.95"Dia.X5.13"H
AR-015-371H	3/4"NPT	15CFM	Aluminum	Aluminum	Alum./SS/Nylon	Viton	300°F(149°C)	15PSIG(1.0barg)	1.25lbs(0.57kg)	3.95"Dia.X8.13"H
AR-0316-371H	1"NPT	20CFM	Steel	Steel	Anod.Alum.	Buna/Neo	300°F(149°C)	15PSIG(1.0barg)	8lbs(4kg)	7.4"Dia.X8.8"H
AR-0335-371H	1 1/2"NPT	43CFM	Steel	Steel	Anod.Alum.	Buna/Neo	300°F(149°C)	15PSIG(1.0barg)	11lbs(5kg)	7.4"Dia.X15"H
AR-0735-371H	3"NPT	100CFM	Steel	Steel	Anod.Alum.	Buna/Neo	300°F(149°C)	15PSIG(1.0barg)	17lbs(8kg)	10"Dia.X18"H
AR-0780-371H	3"NPT	200CFM	Steel	Steel	Anod.Alum.	Buna/Neo	300°F(149°C)	15PSIG(1.0barg)	23lbs(10kg)	10"Dia.X28"H
AR-1280-371H	4"Flg.(1)	300CFM	Steel	Steel	Anod.Alum.	Buna/Neo	300°F(149°C)	15PSIG(1.0barg)	90lbs(41kg)	19"Dia.X43"H(5)
AR-1680-371H	4"Flg.(1)	450CFM	Steel	Steel	Anod.Alum.	Buna/Neo	300°F(149°C)	15PSIG(1.0barg)	100lbs(45kg)	19"Dia.X43"H(5)
AR-3080-371H	6"Flg.(1)	850CFM	Steel	Steel	Anod.Alum.	Buna/Neo	300°F(149°C)	15PSIG(1.0barg)	150lbs(68kg)	23"Dia.X43"H(5)

Vacuum Pump Filters

### Ordering Information

For assistance, call toll-free at 1-800-343-4048 8AM to 5PM Eastern Time

Model	No. of Filter Cartridges Required	Replacement Filter Cartridges		Cover (2) (Optional)	No. Pressure Relief Retainers #20222
		Box of 3	Box of 7		
9955-12-371H (3)	1	3/9955-12-371H	—	9955-12-371H	(4)
9956-12-371H (3)	1	3/9956-12-371H	—	9956-12-371H	(4)
AR-009-371H	1	2/BE200-168-371H (6)	—	BE200-168-371H	(4)
AR-015-371H	1	2/BE200-248-371H (6)	—	BE200-248-371H	(4)
AR-0316-371H	3	3/200-16-371H	—	—	19158
AR-0335-371H	3	3/200-35-371H	—	—	19158
AR-0735-371H	7	—	7/200-35-371H	—	19206
AR-0780-371H	7	—	7/200-80-371H	—	19206
AR-1280-371H	12	—	—	200-80-371H	Included
AR-1680-371H	16	—	—	200-80-371H	Included
AR-3080-371H	30	—	—	200-80-371H	Included

Optional Accessories:

- #20222 Pressure Relief Filter Cartridge Retainer, 4-7 psig (0.3-0.5 barg).
- #20217 Pressure Relief Valve, 3-7 psig (0.2-0.5 barg), 1/4" NPT male fitting.
- #11010 Pressure Gage, 0-15 psig (0-1.0 barg), 1/4" male fitting (incl. on Type AR Filter Assemblies)
- Vacuum pump-to-filter adaptors: refer to pages 141-142.
- #19291 Stand for AR-1680-371H, #19290 Stand for AR-3080-371H.
- #19202 Weather Cap for AR-0735-371H, AR-0780-371H.
- #A05-0097 Seal Set for AR-009-371H, AR-015-371H.

#### Notes:

- 1 ANSI 150 lb. hole pattern.
- 2 Cover does not provide leak tight seal.
- 3 Filter cartridge is permanently sealed into housing. The entire unit is disposable.
- 4 Pressure relief filter tube retainer not available in these models.
- 5 Height dimension represents filter housing alone. When assembled with a stand, the height is adjustable from 46" to 56" (117cm to 142 cm).
- 6 This model comes in box of 2, not box of 3.

# Vacuum Pump Inlet & Exhaust Filters

## Inlet Filters for Vacuum Service to $10^{-6}$ Torr

Protect vacuum pumps from damage by solids and liquids

Prevent loss of valuable or hazardous materials

Prevent oil backstreaming



CF-0118-30

Vacuum  
Pump Filters

### Model CF-0112 and CF-0118 for Vacuum Service to $10^{-6}$ Torr

Stainless steel housings with welded KF flange inlet and outlet ports and no drain ports. They are designed to be used primarily with the Grade 102 adsorbent cartridges for prevention of oil backstreaming (see cartridge selection chart to the right). They may also be used with Grade 30 cartridges for removal of high concentrations of solids, but the absence of drain ports precludes the use of CF housings for liquid removal in vacuum applications.

### Filter Selection Chart

Grade 30 Cartridges	For removal of relatively high concentrations of solids
Efficiency:	90% at 0.1 micron
Loss in pumping speed:	9% at maximum flow rate
Materials of construction:	Polypropylene cartridge, EPR seals
Maximum temperature:	180°F (82°C)
Grade 102 Cartridges	For prevention of oil backstreaming and filtration of relatively low concentrations of solids
Efficiency for preventing oil backstreaming:	99.99%
Life: vacuum	Approximately 1000 hours at 10 microns
Efficiency for solids filtration:	99.99% at 0.1 micron
Materials of construction:	Molecular Sieve Type 4A adsorbent, EPR seals
Maximum temperature:	100°F (38°C)



# Vacuum Pump Inlet & Exhaust Filters

## Inlet Filters for Vacuum Service to 10<sup>-6</sup> Torr

### Principal Specifications

Model	CF-0112	CF-0118
Recommended Vacuum Service	10 <sup>-6</sup> Torr	10 <sup>-6</sup> Torr
Max. Flow Rating of Vacuum Pump	3 CFM (5 m <sup>3</sup> /hr)	9 CFM (15 m <sup>3</sup> /hr)
Inlet and Outlet Ports	KF-25	KF-25
Materials of Construction		
Head	304 SS	304 SS
Bowl	304 SS	304 SS
Internals	304 SS	304 SS
Seals	None	None
Maximum Temperature	180°F (82°C) (1)	180°F (82°C) (1)
Shipping Weight	0.5 lbs. (0.2 kg)	0.8 lbs. (0.4 kg)
Dimensions	2.9"W X 4.4"L (7cm X 11cm)	3.9"W X 5.9"L (10cm X 15cm)

### Notes:

- 1 Maximum temperature grade 102 Cartridge is 100°F (38°F).
- 2 Filter Cartridge is permanently sealed into housing. The entire unit is disposable.

Vacuum  
Pump Filters

### Ordering Information

For assistance, call toll-free at 1-800-343-4048 8AM to 5PM Eastern Time

Assembly with Grade 30 Particulate Filter	Assembly with Grade 102 Backstreaming Filter	Number of Filter Cartridges Required (2)
CF-0112-30	CF-0112-102	N/A
CF-0118-30	CF-0118-102	N/A

# Vacuum Pump Inlet & Exhaust Filters

## Inlet Filters for Vacuum Service to 2 Torr

Protect vacuum pumps from damage by solids and liquids

Prevent loss of valuable or hazardous materials

Prevent oil backstreaming



R-009-30

R-015-30

Vacuum  
Pump Filters

**Models CV-0112-30 and CV-0118-30 for hazardous/corrosive applications and low flow applications**

Stainless steel housings with NPT inlet, outlet and drain ports. Used only with Grade 30 filter cartridges.

**Models R-009-30 and R-015-30 for non-hazardous/non-corrosive applications and higher flow applications**

Steel housing with NPT inlet, outlet and drain ports. Used only with Grade 30 filter cartridges.

### Filter Selection Chart

Grade 30 Cartridges	For removal of relatively high concentrations of solids and liquids
Efficiency:	90% at 0.1 micron
Loss in pumping speed:	9% at maximum flow rate
Materials of construction:	Polypropylene cartridge, EPR seals
Maximum temperature:	180°F (82°C)

# Vacuum Pump Inlet & Exhaust Filters

## Inlet Filters for Vacuum Service to 2 Torr

### Principal Specifications

Model	CV-0112-30	CV-0118-30	R-009-30	R-015-30
Recommended Vacuum Service	2 Torr	2 Torr	2 Torr	2 Torr
Max. Flow Rating of Vacuum Pump	3 CFM	9 CFM	9 CFM	15 CFM(1)
Inlet and Outlet Ports	1/2" NPT	3/4" NPT	3/4" NPT	3/4" NPT
Drain Port	1/8" NPT (2)	1/8" NPT (2)	1/8" NPT (2)	1/8" NPT (2)
Materials of Construction				
Head	304 SS	304 SS	Aluminum	Aluminum
Bowl	304 SS	304 SS	Aluminum	Aluminum
Internals	304 SS	304 SS	Aluminum/SS/Nylon	Aluminum/SS/Nylon
Seals	None	None	Viton	Viton
Maximum Temperature	180°F (82°C)	180°F (82°C)	180°F (82°C)	180°F (82°C)
Shipping Weight	0.5 lbs. (0.2 kg)	0.8 lbs. (0.4 kg)	1.0 lbs. (0.45 kg)	1.25 lbs. (0.57 kg)
Dimensions	2.9"W X 4.4"L (7cm X 11cm)	3.9"W X 5.9"L (10cm X 15cm)	3.95"W X 5.13"L (10cm X 13cm)	3.95"W X 8.13"L (10cm X 21cm)

### Ordering Information

For assistance, call toll-free at 1-800-343-4048 8AM to 5PM Eastern Time

Assembly with Grade 30 Particulate Filter	Number of Filter Cartridges Required	Box of 2	Box of 10
CV-0112-30	(3)	—	
CV-0118-30	(3)	—	
R-009-30	1	2/BE100-163-30	BE100-163-30
R-015-30	1	2/BE100-235-30	BE100-235-30

#### Notes:

- 1 For higher flow capacity inlet filters, please consult factory.
- 2 Drain port must be downward for liquid removal.
- 3 Filter cartridge is permanently sealed into housing. The entire unit is disposable.

# Vacuum Pump Inlet & Exhaust Filters

## Recommended Exhaust Filters for Vacuum Pumps

Vacuum Pump Filters

Pump Model No.	Pump Rating CFM (m <sup>3</sup> /hr) (Free Air)	Pump Exhaust (NPT Female Unless Otherwise Noted)	Recommended Balston Filter Non-Hazardous Non-Corrosive Applications	Balston Anodized Aluminum Pump-To-Filter Adaptor (1)	Recommended Balston Filter Hazardous and Corrosive Applications	Balston Stainless Steel Pump-To-Filter Adaptor (1)
<b>Alcatel Pumps</b>						
ZM/ZT 1004A/AC	3.2 (5.4)	NW 25	AR-009	14175	CV-0112	14182
ZM/ZT 1012A	11 (19)	NW 25	AR-015	14173		
ZM/ZT 1030	17 (29)	1" OD Tube	AR-0316			
ZM/ZT 1033	27 (46)	NW 40	AR-0335	14174		
ZT 1060	30 (51)	1.63" OD Tube	AR-0335			
ZT 1063	50 (85)	NW 40	AR-0735	14174 (2)		
ZT 1200A	150 (255)	1.63" OD Tube	AR-0780			
ZM/ZT 2004A	3.2 (5.4)	NW 25	AR-009	14173	CV-0112	14182
ZM/ZT 2007	7 (12)	NW 25	AR-009	14173	CV-0118	14182
ZM/ZT 2008A/AC	7 (12)	NW 25	AR-009	14173	CV-0118	14182
ZM/ZT 2012A/AC/H	11 (19)	NW 25	AR-015	14173		
UM/UT 2020	15.9 (27)	NW 25	AR-015	14173		
ZM/ZT 2030/H	17 (29)	1" OD Tube	AR-0316			
ZM/ZT 2033/C	27 (46)	NW 40	AR-0335	14174		
ZT 2060/H/HUS	30 (51)	1.63" OD Tube	AR-0335			
ZT 2063/C	50 (85)	NW 40	AR-0735	14174 (2)		
ZT 2100A/AC	90 (153)	NW 50	AR-0735			
2002A	1.4 (2.4)	DN16	9955-12, 9956-12		CV-0112	
2005	3.8 (6.5)	DN25	AR-009		CV-0118	
2015	10.6 (18)	DN25	AR-015			
2021	14.6 (25)	DN25	AR-015			
2010	6.8 (12)	DN25	AR-009		CV-0118	
AMD1	0.82 (1.4)	DN16	9955-12, 9956-12		CV-0112	
AMD4	2.36 (4.0)	DN16	9955-12, 9956-12		CV-0112	
A100L	55.8 (95)	DN25	AR-0735			
<b>Roots Vacuum Pumps</b>						
RSV 151	89 (151)	ISO/DN63	AR-0735			
RSV 301	177 (301)	ISO/DN63	AR-0780			
RSV 601	354 (601)	ISO/DN100	AR-1680			
RSV 1002	594 (1009)	ISO/DN100				
LRS1						
RSV 151B+RVP2033D	106 (180)	DN40	AR-0780			
RSV 301B+2033D	212 (360)	DN40	AR-1280			
RSV 301B+RVP 2063D	212 (360)	DN40	AR-1280			
LRS2						
RSV 151+RVP 2021	106 (180)	DN25	AR-0780			
RSV 601+RVP 2033	424 (720)	DN40	AR-1680			
MRS1						
RSV 301B+AMV 200/300	212 (360)	DN50	AR-1280			
RSV 601B+AMV 200/300	212 (360)	DN40	AR-1280			
RSV 1002AMV200/300	424 (720)	DN40	AR-1680			

**Notes:**

1 If no part number is listed, adaptor is not supplied by Parker. In most cases, customer can assemble adaptor from standard pipe fittings. Refer to pages 141-142.  
 2 Requires 3" Male x 1 1/2" Female reducing bushing supplied by customer.

# Vacuum Pump Inlet & Exhaust Filters

## Recommended Exhaust Filters for Vacuum Pumps

Pump Model No.	Pump Rating CFM (m <sup>3</sup> /hr) (Free Air)	Pump Exhaust (NPT Female Unless Otherwise Noted)	Recommended Balston Filter Non-Hazardous Non-Corrosive Applications	Balston Anodized Aluminum Pump-To-Filter Adaptor (1)	Recommended Balston Filter Hazardous and Corrosive Applications	Balston Stainless Steel Pump-To-Filter Adaptor (1)
<b>Balzers Pumps</b>						
UNO/DUO 1.5A	1.0 (2)	KF10	9955-12		CV-0112	
UNO/DUO 004A/B	2.7 (5)	KF25	9955-12	14175	CV-0112	14182
UNO/DUO 008A/B	5.2 (9)	KF25	R-009	14173	CV-0118	14182
UNO/DUO 012A	8.2 (14)	KF25	R-009	14173	CV-0118	14182
UNO/DUO 016B	10.6 (18)	KF25	R-015	14173		
UNO/DUO 030A	19.7 (33)	KF40	AR-0316	14174		
UNO/DUO 060A	39.3 (67)	KF40	AR-0335	14174		
UNO/DUO 250A	157 (267)	ISO 100	AR-0780			
UNO 100	56 (95)	32mm OD Tube (4)	AR-0735			
DUO 100	57 (97)	32mm OD Tube (4)	AR-0735			
UNO/DUO 120A	75.3 (128)	ISO 63	AR-0735			
UNO 170	91.2 (155)	32mm OD Tube (4)	AR-0735			
DUO 170	100 (170)	32mm OD Tube (4)	AR-0735			
BA 251	158.9 (270)	ISO 63	AR-0780			
BA 501	320.7 (545)	ISO 100	AR-1680			
UNO 2.5	1.7 (3)	DN16	9955-12, 9956-12		CV-0112	
UNO 6	3.5 (6)	G 3/8	R-009		CV-0118	
UNO 20	12.4 (21)	ISO-KF25	R-015			
UNO 60	36.5 (62)		AR-0735			
UNO 90	55.3 (94)	DN40	AR-0735			
UNO 200	123.6 (210)	DN	AR-1280			
UNO 240	158.9 (270)	DN	AR-1280			
UNO 400	270.7 (460)	DN63 ISO-F	AR-3080			
UNO 630	400.2 (680)	DN63 ISO-F	AR-3080			
DUO 5	3.5 (6)	DN16	R-009		CV-0118	
DUO 10	7 (12)	DN25	R-015		CV-0118	
DUO 20	14.1 (24)	DN25	R-015			
DUO 35	21.2 (36)	DN40	AR-0335			
DUO 65	41.2 (70)	DN100	AR-0735			
DUO 120	84.7 (144)	DN63	AR-0780			
DUO 250	176.6 (300)	DN100	AR-1280			
<b>Beach-Russ Pumps</b>						
SS 1	6 (10)	3/4"	R-009		CV-0118	
SS 1 1/2	9 (15)	3/4"	R-009		CV-0118	
SS 2	15 (25)	3/4"	R-015			
SS 3	28 (48)	1"	AR-0335			
SS 4	45 (76)	1 1/4"	AR-0735			
SS 5	60 (102)	1 1/2"	AR-0735			
RP/RV 6	8.5 (14)	1/2"	R-009		CV-0118	
SS 6	75 (127)	1 1/2"	AR-0735			
SS 7	110 (187)	2"	AR-0780			
SS 8	150 (255)	2 1/2"	AR-0780			
SS 9	225 (382)	4"	AR-1280			
SS 10	375 (637)	6"	AR-1680			
RP/RV 12	18 (31)	3/4"	AR-0316			
RP 15	30 (51)	1 1/2"	AR-0335			
RP 15-6	30 (51)	1"	AR-0335			
RP 30	50 (85)	1 1/2"	AR-0735			
RP 30-6	50 (85)	1"	AR-0735			
RP 50/50-6	80 (136)	2"	AR-0735			

Notes:

3 Requires 2" Male x 1 1/2" Female reducing bushing supplied by customer.

4 Exhaust port is horizontal. Customer should provide elbow so that filter is mounted vertically.

5 Requires 1" Male x 1 1/2" Female bushing supplied by customer.

6 Multiple filters piped in parallel are required.

# Vacuum Pump Inlet & Exhaust Filters

## Recommended Exhaust Filters for Vacuum Pumps

Pump Model No.	Pump Rating CFM (m <sup>3</sup> /hr) (Free Air)	Recommended Pump Exhaust (NPT Female Unless Otherwise Noted)	Recommended Balston Filter Non-Hazardous Non-Corrosive Applications	Balston Anodized Aluminum Pump-To-Filter Adaptor (1)	Balston Filter Hazardous and Corrosive Applications	Balston Stainless Steel Pump-To-Filter Adaptor (1)
<b>Beach-Russ Pumps</b>						
RP 135/135-12	140 (238)	3"	AR-0780			
RP-150/150-12	175 (297)	3"	AR-0780			
RP 250	310 (527)	5"	AR-1280			
RP 250-12	310 (527)	4"	AR-1280			
RP 325	375 (637)	5"	AR-1680			
RP 325-12	375 (637)	4"	AR-1680			
RP 375	500 (850)	6"	AR-3080			
RP 375-50	500 (850)	4"	AR-3080			
RP 750	900 (1529)	8"	AR-1680 (2)			
RP 750-50	900 (1529)	5"	AR-1680 (2)			
RP 1000	1100 (1869)	8"	AR-3080 (2)			
RP 1000-50	1100 (1869)	5"	AR-3080 (2)			
84-A-RVF	250 (425)		AR1280			
98-A-RVF	410 (697)		AR1680			
14	8.5 (14)	4"	R-009		CV-0118	
20	12 (20)	4"	R-015			
25	17 (29)	4"	AR-0316			
42	25 (42)	4"	AR-0335			
60	38 (65)	4"	AR-0335			
82	49 (83)	4"	AR-0735			
128	75 (127)	4"	AR-0735			
170	103 (175)	4"	AR-0780			
240	141 (240)	4"	AR-0780			
320	189 (321)	4"	AR-0780			
480	285 (484)	4"	AR1280			
642	378 (642)	4"	AR1680			
910	540 (917)	4"	AR-3080			
1210	710 (1206)	4"	AR-3080			
OTL/VP30	50 (85)	1.5"	AR-0735			
OTL/VP50	80 (136)	2"	AR-0735			
OTL/VP135	140 (238)	3"	AR-0780			
OTL/VP150	175 (297)	3"	AR-0780			
OTL/VP250	310 (527)	5"	AR-1680			
OTL/VP325	375 (637)	5"	AR-1680			
3P	48 (82)	1.5"	AR-0735			
4P	73 (124)	1.5"	AR-0735			
5P	100 (170)	2.5"	AR-0780			
6P	125 (212)	2.5"	AR-0780			
7P	175 (297)	3"	AR-0780			
8P	225 (382)	3"	AR-1280			
9P	300 (510)	4"	AR-1280			
0	1 (2)	1/4"	9955-12, 9956-12		CV-0112	
1	2 (3)	1/4"	9955-12, 9956-12		CV-0112	

**Notes:**

- 1 If no part number is listed, adaptor is not supplied by Parker. In most cases, customer can assemble adaptor from standard pipe fittings. Refer to pages 141-142.
- 2 Multiple filters piped in parallel are required.

# Vacuum Pump Inlet & Exhaust Filters

## Recommended Exhaust Filters for Vacuum Pumps

Pump Model No.	Pump Rating CFM (m <sup>3</sup> /hr) (Free Air)	Pump Exhaust (NPT Female Unless Otherwise Noted)	Recommended Balston Filter Non-Hazardous Non-Corrosive Applications	Balston Anodized Aluminum Pump-To-Filter Adaptor (1)	Recommended Balston Filter Hazardous and Corrosive Applications	Balston Stainless Steel Pump-To-Filter Adaptor (1)
<b>Busch Pumps</b>						
002-192	1.4 (2.4)	KF-16	9956-12		CV-0112	14181
004-192	2.8 (4.8)	KF-16	9956-12		CV-0112	14181
008-192	5.6 (10)	KF-16	R-009	14172	CV-0118	14181 (4)
010-112/118	6 (10)	3/4"	R-009		CV-0118	
016-192	11.2 (19)	KF-16	R-015			
016-112/118	8 (14)	3/4" (3)	R-009		CV-0118	
021-336/338	15 (25)	3/4" (3)	R-015			
025-132/138	20 (34)	1 1/4" (3)	AR-0316			
040-132/138	28 (48)	1 1/4" (3)	AR-0335			
063-132/138	41 (70)	1 1/4" (3)	AR-0335			
110-132/138	63 (107)	1 1/4" (3)	AR-0735			
160-112/118/132/138	117 (199)	2" (3)	AR-0780			
216-002	125 (212)	2"	AR-0780			
225-002	200 (340)	2"	AR-0780			
240-002	300 (510)	2"	AR-1280			
250-112/118/132/138	174 (296)	2" (3)	AR-0780			
263-002	500 (850)	2"	AR-3080			
400-212/218	300 (510)	2"	AR-1280			
630-212/218	430 (731)	3" (3)	AR-1680			
1000-212/228	650 (1104)	6" (3)	AR-3080			
1600-212/228	1100 (1869)	6" (3)	AR-3080 (2)			
429	125 (212)	2"	AR-0780			
433	200 (340)	2"	AR-0780			
437	310 (527)	2"	AR-1280			
441	580 (985)	2"	AR-3080			
445	780 (1325)	6" (3)	AR-3080			
0004	3.3 (506)	3/8"	R-009		CV-0118	
0006	4.2 (701)	3/8"	R-009		CV-0118	
0012	7.1 (12)	3/4"	R-009		CV-0118	
0016	11.2 (19)	3/4"	R-015			
0100	63 (107)	3/4"	AR-0735			
0165	117 (199)	2"	AR-0780			
0205	141 (240)	2"	AR-0780			
0255	180 (306)	2"	AR-0780			
0305	212 (360)	2"	AR-1280			
0400	330 (561)	3"	AR-1680			
0502	413 (702)	3"	AR-1680			
0630	490 (833)	3x	AR-3080			
1000	704 (1196)	6"(ASA)	AR-3080			
1600	1130 (1920)	6"(ASA)	AR-3080(2)			
HO 0429	113 (192)	2"	AR-0780			
HO 0433	176 (299)	2"	AR-0780			
HO 0437	282 (479)	3"	AR-1280			
HO 0441	444 (754)	3"	AR-1680			
LC 0030	20.6 (35)	G1	AR-0335			
LC0060	38.3 (65)	G1	AR-0335			
LC0080	54.1 (92)	DIN40	AR-0735			
LC0110	74.7 (127)	DIN40	AR-0735			
LC0150	100 (170)	DIN40	AR-0735			
LC0220	153 (260)	DIN50	AR-0780			
LC0280	200 (340)	DIN65	AR-0780			
LC0400	271 (460)	DIN65	AR-1280			

**Notes:**

- 1 If no part number is listed, adaptor is not supplied by Parker. In most cases, customer can assemble adaptor from standard pipe fittings. Refer to pages 141-142.
- 2 Multiple filters piped in parallel are required.
- 3 Requires flange to NPT adaptor from pump manufacturer.
- 4 Requires 3/4" Male x 1/2" Female reducing bushing supplied by customer.

# Vacuum Pump Inlet & Exhaust Filters

## Recommended Exhaust Filters for Vacuum Pumps

Vacuum  
Pump Filters

Pump Model No.	Pump Rating CFM (m <sup>3</sup> /hr) (Free Air)	Pump Exhaust (NPT Female Unless Otherwise Noted)	Recommended Balston Filter Non-Hazardous Non-Corrosive Applications	Balston Anodized Aluminum Pump-To-Filter Adaptor (1)	Recommended Balston Filter Hazardous and Corrosive Applications	Balston Stainless Steel Pump-To-Filter Adaptor (1)
<b>Central Scientific Pumps (Cenco, Boekel, HYVAC)</b>						
HYVAC 1 (91105)	0.35 (0.59)	3/8"	9955-12		CV-0112	
HYVAC 2 (91305/8)	0.88 (1.5)	1/2"	9955-12		CV-0112	
HYVAC 4 (91482)	1.70 (2.9)	1/2"	9955-12		CV-0112	
HYVAC 7 (91506, 91502)	2.79 (4.7)	1/2"	9955-12		CV-0112	
HYVAC 7S (91138)	2.79 (4.7)	1/2"	9955-12		CV-0112	
HYVAC 14 (91705)	5.6 (10)	3/4"	R-009		CV-0118	
HYVAC 14S (91140)	5.6 (10)	3/4"	R-009		CV-0118	
HYVAC 28 (91905)	10.6 (18)	1 1/2"	R-015			
HYVAC 28S (91142)	10.6 (18)	1 1/2"	R-015			
HYVAC 45 (91955)	17.7 (30)	1 1/2"	AR-0316			
HYVAC 150 (91957)	53 (90)	3"	AR-0735			
HYVAC 300 (91960)	106 (180)	3"	AR-0780			
MEGAVAC (92003)	2.0 (3.4)	1/2"	9955-12		CV-0112	
<b>PRESSOVAC</b>						
(90510/15/16)	1.23 (2.1)	3.8" OD Tube	9955-12		CV-0112	
DIRECT DRIVE (90703)	1.9 (3.2)	3/8"	9955-12		CV-0112	
DIRECT DRIVE (90700)	1.06 (1.8)	3/8"	9955-12		CV-0112	
2120	4.4 (7.5)	KF25	R-009		CV-0118	
2200	7.3 (12)	KF25	R-009		CV-0118	
HYPERVAC400	13.4 (23)	NW25	R-015			
HYPERVAC600	21 (36)	NW25	AR-0335			
HYPERVAC1000	32 (54)	NW40	AR-0335			
HYPERVAC1500	53 (90)	NW40	AR-0735			
HYVAC30L	1.1 (1.9)		9955-12, 9956-12		CV-0112	
HYVAC50L	2 (3.4)		9955-12, 9956-12		CV-0112	
PRESSOVAC(90510)	1.2 (2.0)	5/8"	9955-12, 9956-12		CV-0112	
MEGAVAC92001	2 (3.4)	1/2"	9955-12, 9956-12		CV-0112	
MEGAVAC1500	50 (85)	PORTS ADAPTABLE	AR-0735			
MEGAVAC2500	88 (150)	PORTS ADAPTABLE	AR-0735			
MEGAVAC4500	150 (255)	PORTS ADAPTABLE	AR-0780			
MEGAVAC7500	250 (425)	PORTS ADAPTABLE	AR-1280			
MEGAVAC15000	300 (510)	PORTS ADAPTABLE	AR-1280			
SUPRVAC012	7.5 (13)	1/2" FNPT	R-009		CV-0118	
SUPRVAC021	15 (25)	1/2" FNPT	R-015			
SUPRVAC025	20 (34)	1"	AR-0335			
SUPRVAC040	30 (51)	1"	AR-0335			
SUPRVAC063	45 (76)	1"	AR-0735			
SUPRVAC100	70 (119)	1"	AR-0735			
SUPRVAC160	110 (187)	2"	AR-0780			
SUPRVAC250	150 (255)	2"	AR-0780			
0505	9.5 (16)	1"	R-015			
1505	19 (32)	1"	AR-0316			
2010	27 (46)	1"	AR-0335			
7530	59 (100)	2"	AR-0735			
10030	84 (143)	2"	AR-0735			

Notes:

1 If no part number is listed, adaptor is not supplied by Parker. In most cases, customer can assemble adaptor from standard pipe fittings. Refer to pages 141-142.

2 Exhaust port is horizontal. Customer should provide elbow so that filter is mounted vertically.

3 Multiple filters piped in parallel are required.

4 Reducing bushing required. Customer to provide.



# Vacuum Pump Inlet & Exhaust Filters

## Recommended Exhaust Filters for Vacuum Pumps

Pump Model No.	Pump Rating CFM (m <sup>3</sup> /hr) (Free Air)	Pump Exhaust (NPT Female Unless Otherwise Noted)	Recommended Balston Filter Non-Hazardous Non-Corrosive Applications	Balston Anodized Aluminum Pump-To- Filter Adaptor (1)	Recommended Balston Filter Hazardous and Corrosive Applications	Balston Stainless Steel Pump-To- Filter Adaptor (1)
<b>Edwards High Vacuum Pumps</b>						
SPEEDIVAC 2	1.9 (3.2)	3/8 BSPT	9955-12	14157	CV-0112	
E2M1	1.3 (2.2)	3/8 BSPT	9955-12	14157	CV-0112	
E2M2	2 (3.4)	3/4 BSPT	9955-12	14158	CV-0112	
E1/E2M5	4 (6.8)	3/4 BSPT	R-009	14159	CV-0118	
EDM6	5 (8.5)	1/2"	R-009		CV-0118	
E1/E2M8	6.7 (11.4)	3/4 BSPT	R-009	14159	CV-0118	
EDM12	10.3 (17.5)	1/2"	R-015			
E1/E2M18	14.7 (25.0)	3/4"	R-015			
EDM20	14.5 (24.6)	1/2"	R-015			
E2M30	30 (51.0)	KF25	AR-0335	14183		
E1/E2M40	30 (51.0)	KF25	AR-0335	14183		
ED/ES 50	3.5 (5.9)	1/4"	R-009		CV-0118	
ED/ES65	2.3 (3.9)	1/4" (2)	9955-12		CV-0112	
E1/E2M80	57 (96.8)	KF25	AR-0735	14183 (4)		
ED/ES100	3.5 (5.9)	1/4" (2)	R-009		CV-0118	
E1/E2M175	125 (212.4)	1 1/2"	AR-0780			
ED/ES200	6.7 (11.4)	3/8" (2)	R-009		CV-0118	
E1/E2M275	145 (246.4)	1 1/2"	AR-0780			
ES330	11.8 (20.0)	3/8" (2)	R-015			
ISC 450	19.6 (33.3)	1/2"	AR-0316			
ED 500	17.7 (30.1)	1/2"	AR-0316			
ED660	23.3 (39.6)	1/2" (2)	AR-0335			
ISC 900	39.2 (66.6)	3/4"	AR-0335			
ES2000	71 (120.6)	1 1/2"	AR-0735			
ES4000	145 (246.4)	1 1/2"	AR-0780			
ES7500	275 (467.2)	2 1/2"	AR-1280			
RV3	2.7 (4.6)	3/4"	9955-12	(4)	CV-0112	(4)
RV5	4.1 (7.0)	NW25	R-009	14173	CV-0118	14182
RV8	6.9 (11.7)	NW25	R-009	14173	CV-0118	14182
RV12	10.0 (17.0)	NW25	R-015	14173		
<b>Gast Pumps</b>						
0211	1.1 (1.9)	1/4"	9955-12		CV-0112	
0240	1.9 (3.2)	1/4"	9955-12		CV-0112	
0322	2.5 (4.2)	1/4"	9955-12		CV-0112	
0440	4.0 (6.8)	1/4"	R-009		CV-0118	
0465	4.0 (6.8)	3/8"	R-009		CV-0118	
0522	4.0 (6.8)	1/4"	R-009		CV-0118	
0740	5.9 (10.0)	3/8"	R-009		CV-0118	
0765	5.9 (10.0)	3/8"	R-009		CV-0118	
0822	7.2 (12.2)	3/8"	R-009		CV-0118	
1022	10.0 (17.0)	3/8"	R-015			
1065	8.3 (14.1)	1/2"	R-009		CV-0118	
1550	11.5 (19.5)	1/2"	R-015			
2065	17.0 (28.9)	3/4"	AR-0316			
2067	17.0 (28.9)	3/4"	AR-0316			
2565	21.0 (35.7)	3/4"	AR-0335			
3040	31.0 (52.7)	1"	AR-0335			
4565	48.0 (81.6)	3/4"	AR-0735			
5565	55.0 (93.4)	1"	AR-0735			

**Notes:**

- 1 If no part number is listed, adaptor is not supplied by Parker. In most cases, customer can assemble adaptor from standard pipe fittings. Refer to pages 141-142.
- 2 Exhaust port is horizontal. Customer should provide elbow so that filter is mounted vertically.
- 3 Multiple filters piped in parallel are required.
- 4 Reducing bushing required. Customer to provide.

# Vacuum Pump Inlet & Exhaust Filters

## Recommended Exhaust Filters for Vacuum Pumps

Pump Model No.	Pump Rating CFM (m <sup>3</sup> /hr) (Free Air)	Pump Exhaust (NPT Female Unless Otherwise Noted)	Recommended Balston Filter Non-Hazardous Non-Corrosive Applications	Balston Anodized Aluminum Pump-To-Filter Adaptor (1)	Recommended Balston Filter Hazardous and Corrosive Applications	Balston Stainless Steel Pump-To-Filter Adaptor (1)
<b>Gast Pumps</b>						
4BA-1-G482X	1.8 (3.1)	1/2"	9955-12		CV-0112	
4AB-1-G482X	1.8 (3.1)	1/2"	9955-12		CV-0112	
4BA-1-G492X	1.8 (3.1)	1/2"	9955-12		CV-0112	
4BA-1-G499	1.8 (3.1)	1/2"	9955-12		CV-0112	
4BA-1-G511X	1.8 (3.1)	1/2"	9955-12		CV-0112	
4BA-1-G538X	1.8 (3.1)	1/2"	9955-12		CV-0112	
5BA-1-G482X	3.5 (3.1)	1/2"	R-009		CV-0118	
5AB-1-G482X	3.5 (5.9)	1/2"	R-009		CV-0118	
5BB-1-G482X	3.5 (5.9)	1/2"	R-009		CV-0118	
6BA-1-G535X	7.0 (12)	1"	R-009			
6AB-1-G504X	7.0 (12)	1"	R-009			
7BA-1-G506X	10.6 (18)	1"	R-015			
7AB-1-G506X	10.6 (18)	1"	R-015			
8BA-1-G506X	14.1 (24)	1 1/4"	R-015			
8AB-G506X	14.1 (24)	1 1/4"	R-015			
1531	1.5 (2.5)	1/8"	9955-12, 9956-12		CV-0112	
0532	0.6 (1.0)	1/8"	9955-12, 9956-12		CV-0112	
1032	1.1 (1.9)	1/4"	9955-12, 9956-12		CV-0112	
1532	1.5 (2.5)	1/4"	9955-12, 9956-12		CV-0112	
2032	2.5 (4.2)	1/4"	9955-12, 9956-12		CV-0112	
3032	2.6 (4.4)	1/4"	9955-12, 9956-12		CV-0112	
0211	1.3 (2.2)	1/4"	9955-12, 9956-12		CV-0112	
2070	20 (34)	1"	AR-0335			
0323-1423	13 (22)	3/4"	AR-0316			
0533	0.6 (1.0)	1/4"	9955-12, 9956-12		CV-0112	
1033	1.1 (1.9)	1/4"	9955-12, 9956-12		CV-0112	
1034	1.6 (2.7)	1/4"	9955-12, 9956-12		CV-0112	
1534	2.2 (3.7)	1/4"	9955-12, 9956-12		CV-0112	
0240-0740	6 (10)	3/8"	R-009		CV-0118	
0456	4 (6.8)	3/8"	R-009		CV-0118	
0765	6 (10)	3/8"	R-009		CV-0118	
1550	14.5 (25)	1/2"	R-015			
1065-2565	8.5-21 (14-36)	3/4"	AR-0335			
2067-2567	17-21 (29-36)	3/4"	AR-0335			
3040	40 (68)	3/4"	AR-0335			
4565	47.5 (81)	1"	AR-0735			
5565	55 (93)	1"	AR-0735			
6066	55 (93)	1"	AR-0735			
1290	112 (190)	1"	AR-0780			
<b>Hitachi Pumps</b>						
SVF 10F	3.6 (6.1)	M24 x 1	R-009	14168	CV-0118	
SVR 16F	5.7 (10)	M24 x 1	R-009	14168	CV-0118	
100 VPS	3.6 (6.1)	M24 x 1	R-009	14168	CV-0118	
160 VPD/VPS	5.7 (10)	M24 x 1	R-009	14168	CV-0118	
16 VP	5.7 (10)	M24 x 1	R-009	14168	CV-0118	
3 VPC	1.8 (3.1)	M14 x 1	9955-12		CV-0112	
4 VPC	3.5 (5.9)	M14 x 1	R-009		CV-0118	

Notes:

- 1 If no part number is listed, adaptor is not supplied by Parker. In most cases, customer can assemble adaptor from standard pipe fittings. Refer to pages 141-142.
- 2 Multiple filters piped in parallel are required.

# Vacuum Pump Inlet & Exhaust Filters

## Recommended Exhaust Filters for Vacuum Pumps

Pump Model No.	Pump Rating CFM (m <sup>3</sup> /hr) (Free Air)	Pump Exhaust (NPT Female Unless Otherwise Noted)	Recommended Balston Filter Non-Hazardous Non-Corrosive Applications	Balston Anodized Aluminum Pump-To-Filter Adaptor (1)	Recommended Balston Filter Hazardous and Corrosive Applications	Balston Stainless Steel Pump-To-Filter Adaptor (1)
<b>Ingersoll-Rand Pumps</b>						
AV/AVX2	2.7 (4.6)	3/8"	9955-12		CV-0112	
BV/BVX2	5.4 (9.2)	3/8"	R-009		CV-0118	
V23A/V23AX7	9 (15)	3/4"	R-009		CV-0118	
V235/V235X1	18 (31)	1"	AR-0316			
V244/V244X2	32 (54)	1 1/4"	AR-0335			
V255/V255X3	60 (102)	1 1/2"	AR-0735			
V255X5	60 (102)	1 1/2"	AR-0735			
7V/7VX5	99 (168)	1 1/2"	AR-0735			
15V/15VX7	133 (226)	2"	AR-0780			
20VX10	214 (364)	2 1/2"	AR-1280			
20V/20VX15	294 (500)	2 1/2"	AR-1280			
15VD7.5	132 (224)	2"	AR-0780			
20VX15	214 (364)	2.5"	AR-1280			
2V235D1.5	36 (61)		AR-0335			
2-V244D2	36 (61)		AR-0335			
2-V255031D5	120 (204)		AR-0780			
2-7E7.5	198 (336)		AR-0780			
2-15VE7.5	264 (449)		AR-1280			
2-20VA15	428 (727)		AR-1680			
2-20VA20	588 (999)		AR-3080			
255	60 (102)	1.5"	AR-0735			
<b>ITT Pneumotive (Leiman Brothers)</b>						
B	10 (17)	3/4"	R-015			
C	18 (31)	1"	AR-0316			
29-3J	20 (34)	1"	AR-0316			
195-2	20 (34)	3/4"	AR-0316			
C-3	22 (37)	1"	AR-0335			
30-3	35 (59)	1"	AR-0335			
C-6	37 (63)	1 1/2"	AR-0335			
29-6J	50 (85)	1 1/2"	AR-0735			
30-6	60 (102)	1 1/2"	AR-0735			
100	112 (190)	1 1/2"	AR-0780			
100J	125 (212)	1 1/2"	AR-0780			
107/107J	200 (340)	3'	AR-0780			

Notes:

1 If no part number is listed, adaptor is not supplied by Parker. In most cases, customer can assemble adaptor from standard pipe fittings. Refer to pages 141-142.

2 Multiple filters piped in parallel are required.

# Vacuum Pump Inlet & Exhaust Filters

## Recommended Exhaust Filters for Vacuum Pumps

Vacuum  
Pump Filters

Pump Model No.	Pump Rating CFM (m <sup>3</sup> /hr) (Free Air)	Pump Exhaust (NPT Female Unless Otherwise Noted)	Recommended Balston Filter Non-Hazardous Non-Corrosive Applications	Balston Anodized Aluminum Pump-To-Filter Adaptor (1)	Recommended Balston Filter Hazardous and Corrosive Applications	Balston Stainless Steel Pump-To-Filter Adaptor (1)
<b>Kinney Pumps</b>						
KC/KVS/KVC-2	2 (3.4)	3/4"	9955-12		CV-0112	
KC/KVC-3	3 (5.1)	3/4"	9955-12		CV-0112	
KC-5	5 (8.5)	3/4"	R-009		CV-0118	
KVC-6	5.8 (9.9)	3/4"	R-009		CV-0118	
KC-8	8 (13.6)	3/4"	R-009			
KS-13	13 (22.1)	1 1/4"	R-015			
TCS-14	14 (23.8)	3/4"	R-015			
KC-15	15 (25.5)	1 1/4"	R-015			
KS-15	15 (25.5)	1 1/4"	R-015			
KTC-21	21 (35.7)	1"	AR-0335			
TCS-21	21 (35.7)	3/4"	AR-0335			
KD-30	33 (56.1)	1 1/4"	AR-0335			
TCS-35	30 (51.0)	1 1/4"	AR-0335	14174		
KD-50	52 (88.3)	1 1/4"	AR-0735			
TCS-55	54 (91.7)	1 1/2"	AR-0735			
KTC-60	60 (101.9)	1 1/2" (2)	AR-0735			
KDH-65	69 (117.2)	1 1/2"	AR-0735			
TCS-70	71 (120.6)	1 1/2"	AR-0735			
KDH-80	83 (141.0)	1 1/2"	AR-0735			
TCS-90	88 (149.5)	2"	AR-0735			
KTC-112	107 (181.8)	2" (2)	AR-0780			
KDH-130	134 (227.7)	2"	AR-0780			
KDH-150	165 (280.3)	2"	AR-0780			
KT-150	144 (244.7)	2" (2)	AR-0780			
KTC-225	221 (375.5)	3" (2)	AR-1280			
KT-300	296 (502.9)	3" (2)	AR-1280			
KT-500	494 (839.3)	3" (2)	AR-3080			
KT-850	778 (1321.8)	4" Flange	AR-3080			
KT-170LP	100 (169.9)	2"	AR-0735			
KT-275LP	162 (275.2)	2"	AR-0780			
KT-505LP	300 (509.7)	3"	AR1680			
KT-840FP	490 (832.5)	4"	AR-3080			
KT-135VFP	780 (1325.2)	5"	AR-3080			
<b>Lammert Pumps</b>						
10301	2 (3.4)	1/2"	9955-12		CV-0112	
10302	2 (3.4)	1/2"	9955-12		CV-0112	
10305/01131	5 (8.5)	3/4"	R-009		CV-0118	
10307/01133	7.5 (12.7)	1"	R-009		CV-0118	
10310/02131	10 (17.0)	1"	R-015			
02133	15 (25.5)	3/4"	R-015			
03131/03231	20 (34.0)	1 1/4"	AR-0316			
04231/04131	30 (51.0)	1 1/4"	AR-0335			
03133/03233	30 (51.0)	1 1/4"	AR-0335			
04133/04233	50 (85.0)	1 1/4"	AR-0735			
05131/05231	75 (127.4)	2"	AR-0735			
06231/05133/05233	100 (169.9)	2"	AR-0735			
07231	125 (212.4)	3"	AR-0780			
06233/08231	150 (254.9)	3"	AR-0780			
07233	200 (339.8)	3"	AR-0780			
08233/09231	250 (424.8)	3"	AR-1280			
09233	350 (594.7)	3"	AR-1680			

**Notes:**

1 If no part number is listed, adaptor is not supplied by Parker. In most cases, customer can assemble adaptor from standard pipe fittings. Refer to pages 141-142.

2 Exhaust port is horizontal. Customer should provide elbow so that filter is mounted vertically.

3 Multiple filters piped in parallel are required.

# Vacuum Pump Inlet & Exhaust Filters

## Recommended Exhaust Filters for Vacuum Pumps

Pump Model No.	Pump Rating CFM (m <sup>3</sup> /hr) (Free Air)	Pump Exhaust (NPT Female Unless Otherwise Noted)	Recommended Balston Filter Non-Hazardous Non-Corrosive Applications	Balston Anodized Aluminum Pump-To-Filter Adaptor (1)	Recommended Balston Filter Hazardous and Corrosive Applications	Balston Stainless Steel Pump-To-Filter Adaptor (1)
<b>Leybold Heraeus Pumps</b>						
D/S 2A	2.2 (3.7)	KF 16	9956-12		CV-0112	14181
D/S 4A	4.5 (7.6)	KF 16	R-009	14172	CV-0118	14181 (3)
D/S 8A	7.0 (12)	KF 25	R-009	14173	CV-0118	14182
D 4B	3.4 (5.8)	KF 16	R-009	14172	CV-0118	14181 (3)
D 8B	6.9 (12)	KF 16	R-009	14172	CV-0118	14181 (3)
D/S 16A	14.1 (24)	KF 25	R-015	14173		
D25	20 (34)	KF 25	AR-0316	14173		
D/S 30A	26.8 (46)	KF 40	AR-0335	14178		
SV 40	30 (51)	1 1/4"	AR-0335			
DK 50	32 (54)	KF 50	AR-0335			
D/S 60A	36.7 (62)	KF 40	AR-0335	14178		
D 65	53 (90)	KF 40	AR-0735	14174 (4)		
SV 65	45 (76)	1 1/4"	AR-0335			
E 75	49 (83)	KF 50	AR-0735			
D/S 90A	55 (93)	KF 40	AR-0735	14174 (4)		
DK 100	65 (110)	KF 50	AR-0735			
SV 100	70 (119)	2"	AR-0735			
E 150	94 (160)	KF 50	AR-0735			
SV 180	125 (212)	2"	AR-0780			
DK 200	130 (221)	3" ASA Flange	AR-0780			
E 250	162 (275)	3" ASA Flange	AR-0780			
SV 280	200 (340)	2"	AR-0780			
SV 500	318 (540)	3"	AR-1280			
SV 580	339 (574)	3"	AR-1680			
D25BCS	20 (34)		AR-0316			
D40BCS	32.5 (55)		AR-0335			
D65BCS	53 (90)		AR-0735			
D25B	20.9 (36)		AR-0335			
SV16B	11.2 (19)		AR-0316			
SV25B	18.3 (31)	1/2" NPT	AR-0136			
SV65B	41.8 (71)		AR-0335			
SV100B	68.9 (117)		AR-0735			
SV200	129.5 (220)		AR-0780			
SV300	200 (340)	2" BSP	AR-0780			
SV500	336 (571)		AR-1680			
SV630	494.8 (841)		AR-3080			
SV1200	677 (1150)		AR-3080			
SP250	177 (301)		AR-0780			
SP630	371 (630)		AR-1680			
SV40B	31.2 (53)		AR-0335			
D10E	9.3 (16)		R-015			

**Notes:**

- 1 If no part number is listed, adaptor is not supplied by Parker. In most cases, customer can assemble adaptor from standard pipe fittings. Refer to pages 141-142.
- 2 Requires 2" Male x 1 1/2" Female reducing bushing supplied by customer.
- 3 Requires 3/4" Male x 1/2" Female reducing bushing supplied by customer.
- 4 Requires 3" Male x 1 1/2" Female reducing bushing supplied by customer.
- 5 Requires Multiple Filters piped in parallel.

Vacuum Pump Filters

# Vacuum Pump Inlet & Exhaust Filters

## Recommended Exhaust Filters for Vacuum Pumps

Vacuum  
Pump Filters

Pump Model No.	Pump Rating CFM (m <sup>3</sup> /hr) (Free Air)	Pump Exhaust (NPT Female Unless Otherwise Noted)	Recommended Balston Filter Non-Hazardous Non-Corrosive Applications	Balston Anodized Aluminum Pump-To-Filter Adaptor (1)	Recommended Balston Filter Hazardous and Corrosive Applications	Balston Stainless Steel Pump-To-Filter Adaptor (1)
<b>Marvac Pumps</b>						
A-1	1.06 (1.8)	3/8"	9955-12		CV-0112	
A-2	1.06 (1.8)	3/8"	9955-12		CV-0112	
A-10	1.6 (2.7)	3/8"	9955-12		CV-0112	
A-20	1.6 (2.7)	3/8"	9955-12		CV-0112	
A-222	3.5 (5.9)	1/2"	R-009		CV-0118	
B-2	2.65 (4.5)	1/2"	9955-12		CV-0112	
B-3	5.5 (9.3)	3/4"	R-009			
B-6	20 (34.0)	1 1/4"	AR-0316			
B-20	3.53 (6.0)	1/2"	R-009		CV-0118	
B-30	8.8 (15.0)	1"	R-009		CV-0118	
B-222	7 (11.9)	3/4"	R-009		CV-0118	
R-10	1.5 (2.5)	3/8"	9955-12		CV-0112	
R-20	1.5 (2.5)	3/8"	9955-12		CV-0112	
R-22	2.65 (4.5)	3/8"	9955-12		CV-0112	
R-55	5.5 (9.3)	3/8"	R-009		CV-0118	
<b>Maxima Pumps (Fisher Scientific)</b>						
D2A (01-057-2A)	2.2 (3.7)	KF 16	9956-12		CV-0112	14181
D4A (01-057-4A)	4.5 (7.6)	KF 16	R-009	14172	CV-0118	14181 (3)
D8A (01-057-8A)	7.0 (11.9)	KF 25	R-009	14173	CV-0118	14182
D16A (01-057-16A)	14.1 (24.0)	KF 25	AR-0316	14173		
D30A (01-057-30A)	26.8 (45.5)	KF 40	AR-0335	14174		
D60A (01-057-60A)	36.7 (62.4)	KF 40	AR-0335	14174 (4)		
D90A (01-057-90A)	55 (93.4)	KF 40	AR-0735			
M4C	2.6 (4.4)		9955-12, 9956-12		CV-0112	
M6C	3.4 (5.8)		R-009		CV-0118	
M8C	6.1 (10.4)		R-009		CV-0118	
<b>Precision Scientific Pumps</b>						
DD-20	0.7 (1.2)	3/4"	9955-12		CV-0112	
D-25	0.9 (1.5)	3/4"	9955-12		CV-0112	
S/PV-35	1.25 (2.1)	3/4"	9955-12		CV-0112	
DD-50	1.77 (3.0)	3/4"	9955-12		CV-0112	
D-75	2.7 (4.6)	3/4"	9955-12		CV-0112	
DD-90	3.2 (5.4)	3/4"	R-009		CV-0118	
DD-100	3.54 (6.0)	3/4"	R-009		CV-0118	
D-150	5.3 (9.0)	3/4"	R-009		CV-0118	
DD/DDC-195	7 (11.9)	3/4"	R-009		CV-0118	
S/D-300	10.6 (18.0)	1"	R-015			
DD/DDC 310	11 (18.7)	3/4"	R-015			
DD/DDC 475	17 (28.9)	3/4"	AR-0316			
S/D-500	17.6 (29.9)	1 1/4"	AR-0316			
S/D-1000	35.3 (60.0)	1 1/2"	AR-0335			
S/D-1500	53 (90.0)	1 1/2"	AR-0735			

**Notes:**

- 1 If no part number is listed, adaptor is not supplied by Parker. In most cases, customer can assemble adaptor from standard pipe fittings. Refer to pages 141-142.
- 2 Multiple filters piped in parallel are required.
- 3 Requires 1 1/2" Male x 1" Female reducing bushing supplied by customer.
- 4 Requires 3" Male x 1 1/2" Female reducing bushing supplied by customer.
- 5 Requires 2" Male x 1 1/2" Female reducing bushing supplied by customer.

# Vacuum Pump Inlet & Exhaust Filters

## Recommended Exhaust Filters for Vacuum Pumps

Pump Model No.	Pump Rating CFM (m <sup>3</sup> /hr) (Free Air)	Pump Exhaust (NPT Female Unless Otherwise Noted)	Recommended Balston Filter Non-Hazardous Non-Corrosive Applications	Balston Anodized Aluminum Pump-To-Filter Adaptor (1)	Recommended Balston Filter Hazardous and Corrosive Applications	Balston Stainless Steel Pump-To-Filter Adaptor (1)
<b>Quincy Pumps</b>						
QSVB-10	79 (134)	1 1/4"	AR-0735			
QSVB-20	134 (228)	1 1/4"	AR-0780			
QSVI-20	159 (270)	2 1/2"	AR-0780			
QSVI-40	315 (535)	2 1/2"	AR-1280			
QV-.75	8.5 (14)	.5" NPT	R-009		CV-0118	
QV-1	12 (20)	.5" NPT	R-015			
QV-1.5	25 (42)	.75" NPT	AR-0335			
QV-2	38 (65)	1" NPT	AR-0335			
QV-3	50 (85)	1" NPT	AR-0735			
QV-5	75 (127)	1.5" NPT	AR-0735			
QV-5.5	103 (175)	1.5" NPT	AR-0780			
QV-7.5	141 (240)	2" NPT	AR-0780			
QV-10	189 (621)	2" NPT	AR-0780			
QV-15	245 (416)	3" NPT	AR-1280			
QV-20	378 (642)	3" NPT	AR-1680			
QV-30	540 (917)	4" NPT	AR-3080			
QV-40	716 (1216)	4" NPT	AR-3080			

**Notes:**

- 1 If no part number is listed, adaptor is not supplied by Parker. In most cases, customer can assemble adaptor from standard pipe fittings. Refer to pages 141-142.
- 2 Multiple filters piped in parallel are required.
- 3 Requires 1 1/2" Male x 1" Female reducing bushing supplied by customer.
- 4 Requires 3" Male x 1 1/2" Female reducing bushing supplied by customer.
- 5 Requires 2" Male x 1 1/2" Female reducing bushing supplied by customer.

# Vacuum Pump Inlet & Exhaust Filters

## Recommended Exhaust Filters for Vacuum Pumps

Pump Model No.	Pump Rating CFM (m <sup>3</sup> /hr) (Free Air)	Pump Exhaust (NPT Female Unless Otherwise Noted)	Recommended Balston Filter Non-Hazardous Non-Corrosive Applications	Balston Anodized Aluminum Pump-To-Filter Adaptor (1)	Recommended Balston Filter Hazardous and Corrosive Applications	Balston Stainless Steel Pump-To-Filter Adaptor (1)
<b>Rietschle Pumps</b>						
VAL/VL/VE 10	6.8 (12)	NW 25	R-009	14173	CV-0118	14182
VF/VFE/CLFG 11	6.8 (12)	1/2"	R-009		CV-0118	
VF/VFE 16	10.2 (17)	1/2"	R-015			
CLFG/CLF/CLFE 16	10.2 (17)	1/2"	R-015			
VAL/VL/VLV 25	16.9 (29)	NW 25	AR-0316	14173		
VF/VFE 26	16.9 (29)	3/4"	AR-0316			
CLFG/CLF/CLFE 26	16.9 (29)	3/4"	AR-0316			
VL/VLV 40	30 (51)	NW 25	AR-0335	14183		
VF/VFE 41	27 (46)	3/4"	AR-0335			
CLFG/CLF/CLFE 41	27 (46)	3/4"	AR-0335			
VL/VLV 60	40 (68)	3/4"	AR-0335			
VF/VFE 61	40 (68)	3/4"	AR-0335			
CLFG/CLF/CLFE 61	40 (68)	3/4"	AR-0335			
VL/VLV 80	54 (92)	NW 40	AR-0735	14174 (4)		
VF/VFE 81	54 (92)	1"	AR-0735			
CLFG/CLF/CLFE 81	54 (92)	1"	AR-0735			
VL/VLV 100	67 (114)	NW 40	AR-0735	14174 (4)		
VF/VFE 101	67 (114)	1 1/4"	AR-0735			
CLFG/CLF/CLFE 101	67 (114)	1 1/4"	AR-0735			
VWZ 102	67 (114)	NW 65	AR-0735			
CLF/CLFE 141	94 (160)	1 1/2"	AR-0735			
VFH/VFEH 161	108 (183)	2"	AR-0780			
VWZ 162	108 (183)	NW 65	AR-0780			
CLF/CLFE 181	108 (183)	2"	AR-0780			
VWZ 252	169 (287)	NW 65	AR-0780			
CLFH/CLFEH 341	230 (391)	3"	AR-1280			
VWZ 402	270 (459)	NW 65	AR-1280			
CLFH/CLFEH 501	338 (574)	3"	AR-1680			
CLFH/CLFEH 631	426 (724)	3"	AR-1680			
CLFH/CLFEH 1001	677 (1150)	3"	AR-3080			
VLV25-2	18 (31)	3/4" NPT	AR-0316			
VLV25-3	18 (31)		AR-0316			
VLV40-2	28 (48)	3/4" NPT	AR-0335			
VLV40-3	28 (48)		AR-0335			
VWZ702	494 (839)		AR-3080			
VWZ1002	706 (1199)		AR-3080			
VGD10	7 (12)		R-009		CV-0118	
VGD15	11 (19)		R-015			
VCE15	11 (2)	1/2" NPT	R-015			
VCE25	18 (31)	3/4" NPT	AR-0316			
VCE40	28 (48)	1" NPT	AR-0335			
VC50	35 (59)	1-1/4" NPT	AR-0335			
VCE60	42 (71)	1" NPT	AR-0335			
VC75	49 (83)	1-1/4" NPT	AR-0735			
VC100	71 (121)	1-1/2" NPT	AR-0735			
VC150	105 (178)	1-1/2" NPT	AR-0780			
VC200	141 (240)	2" NPT	AR-0780			
VC300	212 (360)	2" NPT	AR-1280			
VC400	282 (479)	3" NPT	AR-1280			
VC500	388 (659)	3" NPT	AR-1680			
VC700	494 (839)	3" NPT	AR-3080			
VC900	636 (1081)	4" NPT	AR-3080			
VC1100	777 (1320)	4" NPT	AR-3080			
VC1300	918 (1560)	4" NPT				
VLR100	72 (122)	1-1/2" NPT	AR-0735			
VLR250	166 (282)	2" NPT	AR-0780			
VL5300	212 (360)	2" NPT	AR-1280			
VLR400	272 (462)	3" NPT	AR-1280			
VLR500	353 (600)	3" NPT	AR-1680			

**Notes:**

1 If no part number is listed, adaptor is not supplied by Parker. In most cases, customer can assemble adaptor from standard pipe fittings. Refer to pages 141-142.

2 Multiple filters piped in parallel are required.

3 Requires 1 1/2" Male x 1" Female reducing bushing supplied by customer.

4 Requires 3" Male x 1 1/2" Female reducing bushing supplied by customer.

5 Requires 2" Male x 1 1/2" Female reducing bushing supplied by customer.



Pump Model No.	Pump Rating CFM (m <sup>3</sup> /hr) (Free Air)	Recommended Pump Exhaust (NPT Female Unless Otherwise Noted)	Balston Filter Non-Hazardous Non-Corrosive Applications	Recommended Balston Anodized Aluminum Pump-To-Filter Adaptor (1)	Balston Filter Hazardous and Corrosive Applications	Balston Stainless Steel Pump-To-Filter Adaptor (1)
----------------	---	--	---	--	---	--

**RO-FLO Pumps (Allis-Chalmers)**

5CCA	55 (93)	1 1/2"	AR-0735			
5CCB	86 (86)	1 1/2"	AR-0735			
7DB	151 (151)	3"AR-0780				
7DC	235 (235)	3"AR-1280				
8DB	275 (275)	3"AR-1280				
8DE	345 (345)	3"AR-1680				
10GB	411 (411)	4"AR-1680				
10GC	593 (593)	4"AR-3080				
11S	738 (738)	5"AR-3080				
11L	838 (838)	5"AR-3080				
12S	970 (970)	6"AR-3080 (2)				
12L	1080 (1080)	6"AR-3080 (2)				
17S	1228 (1228)	6"AR-3080 (2)				
17L	1420 (1420)	6"AR-3080 (2)				
19S	1693 (1693)	8"AR-3080 (2)				
19L	1920 (1920)	8"AR-3080 (2)				
23C	2270 (2270)	8"AR-3080 (2)				
23D	2740 (2740)	8"AR-3080 (2)				
27D	3300 (3300)	10"	AR-3080 (2)			
33D	5950 (10109)	14"	AR-3080 (2)			

**Sargent-Welch Pumps**

1373	10.6 (19)	1-20	R-015	14163		
1374	23 (39)	1-3/4-20	AR-0335	14164		
1375	35 (59)	Square Flange	AR-0335			
1376	10.6 (18)	1-20	R-015 (3)	14163		
1380	5.6 (10)	1-20	R-009	14162	CV-0118	
1392	0.9 (1.5)	3/4-20	9955-12	14165	CV-0112	
1395	71 (121)	Square Flange	AR-0735			
1396	100 (170)	Square Flange	AR-0735			
1397	17.7 (30)	1-3/4-20	AR-0316	14160		
1398	53 (90)	Square Flange	AR-0735			
1399	1.2 (2.1)	3/4-20	9955-12	14165	CV-0112	
1400	0.9 (1.5)	3/4-20	9955-12	14165	CV-0112	
1402	5.6 (10)	1-20	R-009	14162	CV-0118	
1403	3.5 (5.9)	1-20	R-009	14162	CV-0118	
1405	2.1 (3.6)	3/4-20	9955-12	14165	CV-0112	
1410	0.7 (1.2)	1/2" Hose	9955-12		CV-0112	
8802	0.9 (1.5)	3/4-20	9955-12	14165	CV-0112	
8803B/8804B	0.9 (1.5)	3/4-20	9955-12	14165	CV-0112	
8803K/8804K	0.7 (1.2)	3/4-20	9955-12	14165	CV-0112	
8805	1.8 (3.1)	1-20	9955-12	14166	CV-0112	
8806B/K	1.8 (3.1)	NW 25	9955-12	14175	CV-0112	14182
8810	3.5 (5.9)	1-20	9955-12	14166	CV-0118	
8811B	3.5 (5.9)	NW 25	R-009	14173	CV-0118	14182
8811K	2.9 (4.9)	NW 25	9955-12	14175	CV-0112	14182
8814	5.6 (10)	NW 25	R-009	14173	CV-0112	14182
8815	5.3 (9.0)	1-20	R-009	14162	CV-0118	
8816B/K	5.3 (9.0)	NW 25	R-009	14173	CV-0118	14182
8821	7.4 (13)	NW 25	R-009	14173	CV-0118	14182
8830	10.6 (18)	1-3/4-20	R-015	14160		
8834	12 (20)	NW 40	R-015	14174		
8851	18 (31)	NW 40	AR-0316	14174		
8861	35.3 (60)	NW 50	AR-0335			
8871	53 (90)	NW 50	AR-0735			
8890	7.7 (13)	3/4-20	R-009	14173	CV-0118	14182
8905	1.8 (3.1)	NW 16	9956-12		CV-0112	14181
8910	3.8 (6.5)	NW 16	R-009	14172	CV-0118	14181 (4)
8910A	3.1 (5.3)	NW 16	R-009	14172	CV-0118	14181 (4)
8915	5.6 (10)	1-20	R-009	14162	CV-0118	
8920	7.7 (13)	NW 25	R-009	14173	CV-0118	14182

Notes:

- 1 If no part number is listed, adaptor is not supplied by Parker. In most cases, customer can assemble adaptor from standard pipe fittings. Refer to pages 141-142.
- 2 Multiple filters piped in parallel are required.
- 3 Consult factory for piping considerations.
- 4 Requires 3/4" male x 1/2" female reducing bushing supplied by customer.

# Vacuum Pump Inlet & Exhaust Filters

## Recommended Exhaust Filters for Vacuum Pumps

Pump Model No.	Pump Rating CFM (m <sup>3</sup> /hr) (Free Air)	Pump Exhaust (NPT Female Unless Otherwise Noted)	Recommended Balston Filter Non-Hazardous Non-Corrosive Applications	Balston Anodized Aluminum Pump-To-Filter Adaptor (1)	Recommended Balston Filter Hazardous and Corrosive Applications	Balston Stainless Steel Pump-To-Filter Adaptor (1)
<b>Stokes Pumps</b>						
V-005	7 (12)	NW 25	R-009	14173	CV-0118	14182
V-009	11 (19)	NW 25	R-015	14173		
V-013-2	20 (34)	NW 40	AR-0316	14174		
V-017-2	36.7 (62)	NW 40	AR-0335	14174		
V-23	55 (93)	NW 40	AR-0735	14174 (3)		
146H	30 (51)	1 1/4"	AR-0335			
148H	50 (85)	1 1/2"	AR-0735			
149H	80 (136)	1 1/2"	AR-0735			
149HS	100 (170)	1 1/2"	AR-0735			
212HS	150 (255)	2"	AR-0780			
412H	300 (510)	3"	AR-1280			
612H	600 (1019)	3"	AR-3080			
912H	728 (1237)	5"	AR-3080			
212J	150 (255)	" NPT	AR-0780			
412J	300 (510)	3" NPT	AR-1280			
612J	600 (1019)	3" NPT	AR-3080			
<b>Ulvac Pumps</b>						
G-5	0.21 (0.4)	M17 x 1	9955-12		CV-0112	
G-15	0.63 (1.1)	3/4"	9955-12		CV-0112	
G/GC-25S	0.84 (1.4)	3/4"	9955-12		CV-0112	
G/GC-20D	0.84 (1.4)	3/4"	9955-12		CV-0112	
G-50S/D	2.1 (3.6)	3/4"	9955-12		CV-0112	
GC-50D	2.1 (3.6)	3/4"	9955-12		CV-0112	
G-100S/D	4.2 (7.1)	1"	R-009		CV-0118	
GC-100D	4.2 (7.1)	1"	R-009		CV-0118	
GVD-050	2.1 (3.6)	3/4"	9955-12		CV-0112	
GVD-100	5.6 (10)	1"	R-009		CV-0118	
GVD-165	7 (12)	3/4"	R-009		CV-0118	
DA-30S	1.1 (1.9)	3/4"	9955-12		CV-0112	
DA-60S	2.5 (4.2)	3/4"	9955-12		CV-0112	
D-330D	9 (15)	1 1/2"	R-009		CV-0118	
D-650D	18 (31)	1 1/2"	AR-0316			
D-950D	27 (46)	2"	AR-0335			
PKS-016	57 (97)	2"	AR-0735			
PKS-030	107 (182)	3"	AR-0780			
PKS-070	250 (425)	4"	AR-1280			
PVD-180	6.4 (11)	3/4"	R-009		CV-0118	
PDV-360	13 (22)	1"	R-015			
<b>Varian Pumps</b>						
CS/SS/SD-90	3.2 (5.4)	NW 25	R-009	14173	CV-0118	14182
EVAC 200	7 (12)	3/4"	R-009		CV-0118	
EVAC 300	11 (19)	3/4"	R-015			
CD/SD-200	7 (12)	NW 25	R-009	14173	CV-0118	14182
CD/SS/SD-300	11 (19)	NW 25	R-015	14173		
CD/SS/SD-700	27 (46)	NW 40	AR-0335	14174		
CD/SS/SD-1400	50 (85)	NW 40	AR-0735	14173 (3)		
CD/SD-2500	90 (153)	NW 50	AR-0735			

**Notes:**

- 1 If no part number is listed, adaptor is not supplied by Parker. In most cases, customer can assemble adaptor from standard pipe fittings. Refer to pages 141-142.
- 2 Multiple filters piped in parallel are required.
- 3 Requires 3" Male x 1 1/2" Female reducing bushing supplied by customer.
- 4 Requires 2" Male x 1 1/2" Female reducing bushing supplied by customer.

# Vacuum Pump Inlet & Exhaust Filters

## Pump to Filter Adaptors - Straight Thread to NPT Thread

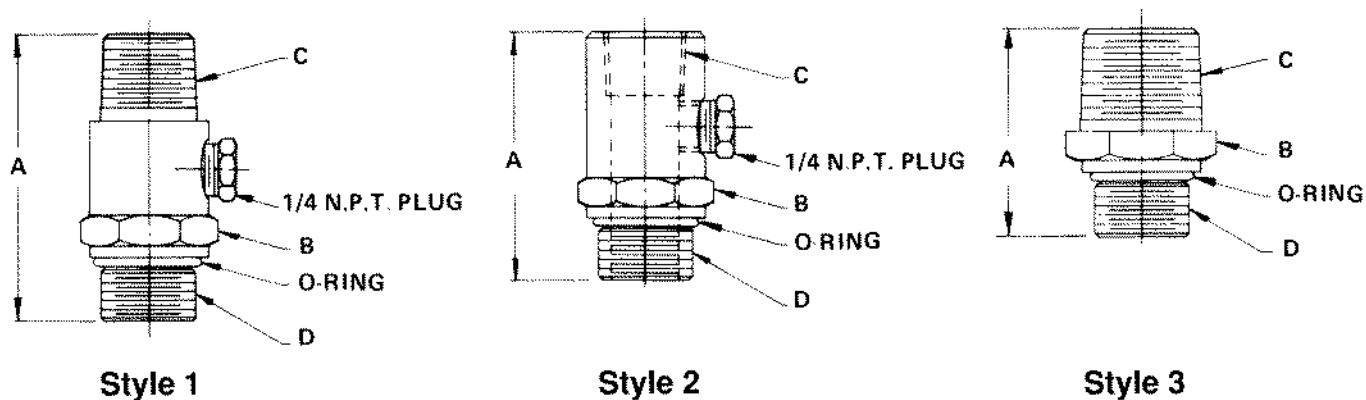

Vacuum Pump Filters

### Principal Specifications

Type	Adaptor Style	Materials of Construction		Dimensions Inches (cm)			
		Adaptor	Seals	(A) Height	(B) Hex Size	(C) NPT Thread	(D) Thread
14168	1	Alum.	Buna-N	3.0 (7.62)	1.25	3/4	M24 x 1
14166	2	↓	↓	2.6 (6.60)	↓	1/2 F (1)	1-20
14165	2			2.44 (6.20)		1/2 F (1)	3/4-20
14164	3			2.88 (7.32)	2.0	1 1/2	1 3/4-20
14163	3			2.19 (5.56)	1.38	1	1-20
14162	1			3.0 (7.62)	1.25	3/4	1-20
14160	3			2.3 (5.84)	2.0	1	1 3/4-20
14159	1			3.15 (8.00)	1.25	3/4	3/4 BSPT (2)
14158	2			2.80 (7.11)	↓	1/2 F (1)	3/4 BSPT (2)
14157	2			2.56 (6.50)		1/2 F (1)	3/8 BSPT (2)

Notes:

1 Female NPT - all others Male.

2 O-ring not supplied on adaptors with tapered threads.

# Vacuum Pump Inlet & Exhaust Filters

## Pump to Filter Adaptors - Flange to NPT Thread

Vacuum Pump Filters

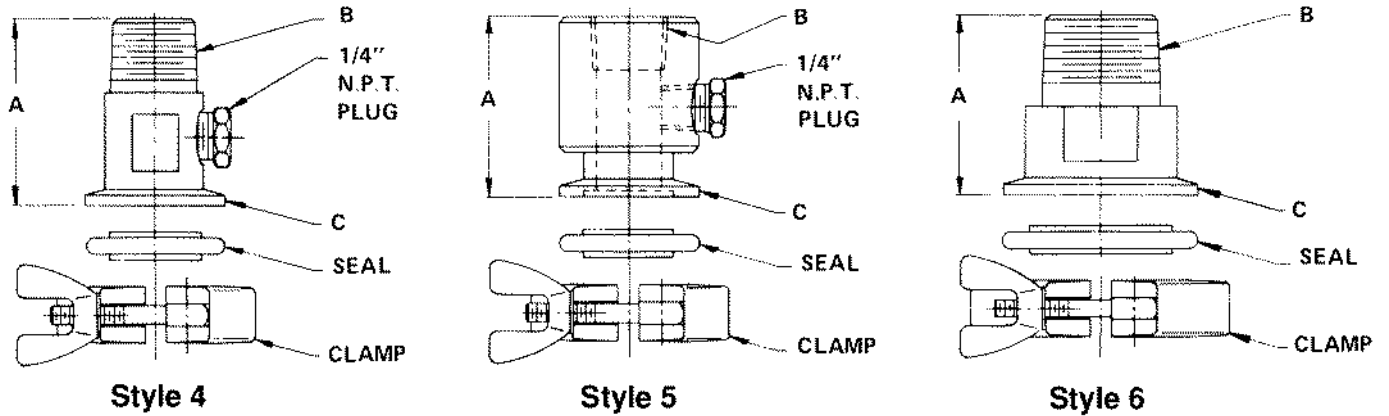

### Principal Specifications

Type	Adaptor Style	Materials of Construction			Dimensions			Other Fittings Included		
		Adaptor	Clamp	Seals	(A) Height inches (cm)	(B) NPT Thread (Inches)	(C) KF Flange (2)			
14183	6	Alum.	↓	↓	2.38 (6.05)	1 1/2	KF-25			
14182	4	Stain. St.			2.06 (5.23)	1/2	KF-25	3/4" x 1/2" Reducing Bushing		
14181	4	Stain. St.			2.12 (5.38)	1/2	KF-16			
14178	↓	↓			2.38 (6.05)	1 1/2	KF-40			
14177	↓	↓			2.0 (5.08)	1	KF-25			
14175	5	Alum.			↓	1/2 F (1)	KF-25			
14174	6	↓			↓	↓	1	KF-40	1 1/2" x 1" Reducing Bushing	
14173	4	↓			↓	↓	3/4	KF-25	1" x 3/4" Reducing Bushing	
14172	4	↓			↓	↓	2.12 (5.83)	1/2	KF-16	1/2" coupling and 3/4" x 1/2" Reducing Bushing

**Notes:**

- 1 Female NPT - all others are Male
- 2 The designation "KF" and "NW" are interchangeable

# Liquid Filters

## Balston LP Depth Filters

The LP-Grades 10,20, and 30 depth filter cartridges are constructed entirely of polypropylene, and the LP-Grades 50, 60, 70, and 80 depth filter cartridges are constructed of polypropylene, borosilicate glass and polyethylene binder. Both types of cartridges provide excellent chemical and solvent resistance. All LP cartridges have a graded efficiency construction: the filtration efficiency increases from the inside surface to the outside surface, in the direction of flow. This construction provides exceptionally high solids holding capacity, which translates into a longer life of the filter cartridge. The seven retention efficiency grades offered cover the ranges from 75 micron to 0.22 micron (see table, on next page).

The Balston LP depth filter cartridges may be used for fine filtration of liquids with heavy dirt loading, when chemical or solvent resistance is required, or as prefilters to ultra-high efficiency or membrane filtration applications.



## Product Features

- Filtration to 0.22 micron with exceptional filter life, even for the dirtiest liquids
- Compliance with FDA regulations for food contact surfaces
- Excellent chemical and solvent resistance
- Seven retention efficiency grades cover the range from 75 micron to 0.22 micron

Gas and Liquid Sample Filtration



Process Filtration

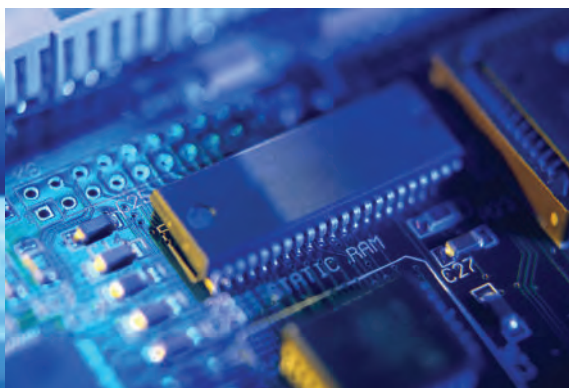

Specialized Chemical or Solvent Filtration



# Liquid Filters

## Filter Cartridge and Housing Selection

### How To Select The Filter Cartridge

- 1 Specify the level of final filtration required, within the range of 75 micron to 0.22 micron.
- 2 Select the filter system using the Final Filter Selection Table below.

Note: The recommendations are based on the assumption that the initial liquid feed is relatively dirty. If the feed has been prefiltered to about 10 micron, the first stage of filtration may be omitted.

### How To Select The Filter Housing

- 1 Determine the number of LP Filter Cartridge stages and Grade of filter at each stage, using the Final Filter Selection Table below.
- 2 Use the flow chart (next page) to determine the sizes of housings required based on the grade of filter cartridge and the liquid flow rate.
- 3 Select the housings of the correct size which are constructed of materials suitable for the application.

### Retention Efficiency Ratings

#### LP Depth Filter Cartridges

Grade	80% Capture Rating
10	75 micron
20	25 micron
30	10 micron
50	1 micron
60	0.6 micron
70	0.4 micron
80	0.22 micron

Retention efficiency v. particle size for the four finer grades of LP depth filters

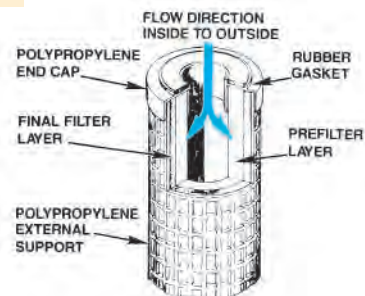
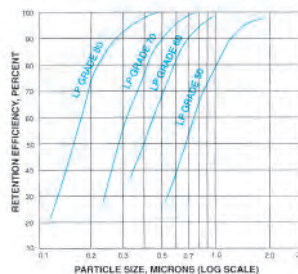

Cross Section of LP-200-50 and LP-200-95 cartridges. Construction of LP-100-12 and LP-100-25 cartridges is similar, but without end caps and gaskets.

Table I Final Filter LP Depth Cartridge

If the Final Filtration Requirement is:	Use This LP Cartridge System		
	1st Stage	2nd Stage	3rd Stage
75 micron	LP Grade 10	—	—
25 micron	LP Grade 20	—	—
10 micron	LP Grade 10	LP Grade 30	—
1 micron	LP Grade 20	LP Grade 50	—
0.6 micron	LP Grade 10	LP Grade 30	LP Grade 60
0.4 micron	LP Grade 20	LP Grade 50	LP Grade 70
0.22 micron	LP Grade 20	LP Grade 50	LP Grade 80

#### Notes:

1 For a liquid with viscosity higher than the viscosity of water (1 centipoise), divide the flow rates in the above table by the viscosity of the liquid in centipoises. Example: for liquid with 10 centipoise viscosity, flow rate with C-0395 housing, Grade 20 cartridges at 10 psi (0.69 barg) drop will be  $132/10 = 13.2$  GPM.

### Flow Rates of Filter with LP Cartridges

Filter Housing Model	Number of Cartridges	Cartridge Length & Designation	Initial Pressure Drop	Water Flow Rate, Gallons (Liters) per Minute LP Cartridges						
				Grade 10	Grade 20	Grade 30	Grade 50	Grade 60	Grade 70	Grade 80
33S6, 33G 58P	1	2 1/2" LP-100-12	5 psi (0.3 bar)	3.5 (13)	3.5 (13)	3.0 (11)	0.75 (2.8)	0.60 (2.3)	0.30 (1.1)	0.07 (0.3)
			10 psi (0.7 bar)	4.3 (16)	4.2 (16)	3.9 (15)	0.95 (3.6)	0.80 (2.0)	0.37 (1.4)	0.10 (0.4)
45S6 45G	1	7" LP-100-25	5 psi (0.3 bar)	5.0 (19)	5.0 (19)	4.3 (16)	1.1 (4.2)	0.90 (3.4)	0.45 (1.7)	0.11 (0.4)
			10 psi (0.7 bar)	6.2 (23)	6.2 (23)	5.4 (20)	1.4 (5.3)	1.2 (4.5)	0.60 (2.3)	0.15 (0.6)
53/18	1	5" LP-200-18	5 psi (0.3 bar)	6 (23)	6 (23)	6 (23)	3.2 (12)	1.3 (4.9)	0.6 (2.3)	0.5 (1.9)
			10 psi (0.7 bar)	11 (42)	11 (42)	11 (42)	6 (23)	2.5 (9.5)	1.0 (3.8)	0.9 (3.4)
27/50 53/50, 54/50	1	10" LP-200-50	5 psi (0.3 bar)	12 (45)	12 (45)	12 (45)	6.4 (24)	2.5 (9.5)	1.2 (4.5)	1.0 (3.8)
			10 psi (0.7 bar)	22 (83)	22 (83)	22 (83)	12 (45)	5 (19)	2.0 (7.6)	1.7 (6.4)
			5 psi (0.3 bar)	24 (91)	24 (91)	24 (91)	13 (49)	5 (19)	2.4 (9.1)	2.0 (7.6)
53/95, 27/95	1	20" LP-200-95	5 psi (0.3 bar)	24 (91)	24 (91)	24 (91)	13 (49)	5 (19)	2.4 (9.1)	2.0 (7.6)
			10 psi (0.7 bar)	44 (167)	44 (167)	44 (167)	24 (91)	10 (38)	4.0 (15)	3.4 (13)

# Liquid Filters

## Filter Cartridge and Housing Selection

### Chemical and Solvent Compatibility

Liquid	LP Cartridge	Liquid	LP Cartridge
Acetic Acid (Glacial)	NR	Hydrochloric Acid (35%)	R
Acetic Acid (5%)	R	Hydrofluoric Acid	NR
Acetone	R	Hydrogen Peroxide	NR
Acetonitrile	R	N-Methyl Pyrrolidone (NMP)	R
Alcohols	R	Methyl Ethyl Ketone (MEK)	R
Ammonia, Liquid or Gas	R (1)	Methyl Isobutyl Ketone (MIBK)	R
Amyl Acetate	N	Methylene Chloride	NR
Ammonium Hydroxide (6N)	R	Metal Etch (H <sub>3</sub> PO <sub>4</sub> /HAC/HNO <sub>3</sub> )	N
B.O.E. (NH <sub>4</sub> F/HF)	NR	Nitric Acid (30%)	R
Butyl Acetate	N	Nitrobenzene	R
Carbon Tetrachloride	NR	Pentane	NR
Chlorine, Liquid or Gas	NR	Perchloroethylene	NR
Chloroform	NR	Phenol	NR
Cyclohexane	NR	Plating Solutions	R
Dimethyl Acetamide(DMAC)	R	Phosphoric Acid (50%)	R
Dimethyl Formamide(DMF)	R	Silicone Oils	R
Dimethyl Sulfoxide (DMSO)	R	Sodium Hydroxide	
Esters	NR	Below 20%	R
Ethanolamine	R	20-45%	R
Ethyl Acetate	R	Above 45%	NR
Ethylene Diamine	R	Steam	NR
Ethylene Glycol	R	Sulfuric Acid (50%)	R
Ethylene Oxide	R	Toluene	NR
Formaldehyde (37%)	R	Trichloroethane	NR
Freon TF	NR	Trichloroethylene	NR
Freon TMC	NR	Water to 180°F (82°C)	R
Hexane	NR	Xylene	NR

Liquid Filters

**Notes:**

1 Grades 10, 20, 30 large diameters only.

In LP200-□ sizes only.

R - Recommended

NR - Not Recommended

N - No data available; consult factory

**Chemical Compatibility:**

The above compatibility data is for the filter cartridges only, at an operating temperature of 70°F (21°C). The filter housing is not necessarily compatible with the same chemicals and solvents.

**Food Grade Applications:**

All LP Filter Cartridges are constructed entirely of materials which are in compliance with FDA regulations for food contact surfaces. All stainless steel liquid filter in this bulletin comply with FDA regulations for food contact applications.

# Liquid Filters

## 1/4" to 3/4" Line Size

### Miniature Model 58P Housing

Has a nylon head, nylon internals, and a clear nylon bowl. The Model 58P Housing accepts a single LP cartridge, and may be used to filter water, mildly acidic, or caustic solutions.

### Model 53 Housings

Are all-polypropylene, designed for a single LP-200 filter cartridge. Polypropylene construction provides excellent resistance to non-oxidizing acids, such as HCL in any concentration, sulfuric to 70% concentration, brines, hydrocarbon liquids, alcohols and concentrated caustic.

The Model 53 Housings may be used with certain ketones and chlorinated solvents. Please see page 105 or contact the Technical Services Dept. for specific recommendations.



54/50



Models  
53/18, 53/50,  
and 53/95 (shown)



Model  
58P



# Liquid Filters

## 1/4" to 3/4" Line Size

### Ordering Information

Model	58P	53/18	53/50	53/95	54/50
Port Size (NPT)	1/4"	3/8"	3/4"	3/4"	3/4"
Material of Construction					
Head	Nylon	Polypropylene	Polypropylene	Polypropylene	Polypropylene
Bowl	Nylon	Polypropylene	Polypropylene	Polypropylene	SAN
Internals	Nylon	—	—	—	—
Seals	EPR	EPR	EPR	EPR	EPR
Max. Temperature	150°F (66°C)	125°F (52°C)	125°F (52°C)	125°F (52°C)	100°F (38°C)
Max. Pressure	125 psig (8.6 barg)	125 psig (8.6 barg)	125 psig (8.6 barg)	125 psig (8.6 barg)	125 psig (8.6 barg)
Max. Differential Press.	60 psig (4.1 barg) (1)	60 psig (4.1 barg) (1)	60 psig (4.1 barg) (1)	60 psig (4.1 barg) (1)	60 psig (4.1 barg) (1)
Shipping Weight	1 lb. (0.5 kg)	3 lbs. (1.3 kg)	4 lbs. (1.8 kg)	6 lbs. (2.7 kg)	4 lbs. (1.8 kg)
Dimensions	2.7"D x 6.1"L (6.9cm x 15cm)	4.4"D x 6.6"L (11cm x 17cm)	5.0"D x 12"L (13cm x 30cm)	5.0"D x 22"L (13cm x 56cm)	5.0"D x 12"L (13cm x 30cm)

### Ordering Information

For assistance, call toll-free at 1-800-343-4048 8AM to 5PM Eastern Time

Model	58P	53/18	53/50	53/95	54/50
LP Filter Cartridges, Depth Filters (2)	LP-100-12-□	LP-200-18-□	LP-200-50-□	LP-200-95-□	LP-200-50-□
Number of Cartridges required	—	1	1	1	1

#### Notes:

- 1 Inside-out flow, LP filter cartridges.
- 2 To order filter cartridges, indicate grade by putting appropriate grade number after size designation. For example, to obtain 0.22 micron depth filter cartridges for the model 53/18, order LP-200-18-80.

# Liquid Filters

## 1" Line Size

### Model 27 Housings

Model 27 housings are constructed of 316 stainless steel. These models have 1" NPT ports and are rated to 800 psig (55 barg). The model 27 housings hold a single LP-200 filter cartridge, available in a 10" (25 cm) or 20" (50 cm) length.



**Models  
27/50, 27/95**

### Principal Specifications

Model	27/50	27/95
Port Size (NPT)	1" (1)	1" (1)
Material of Construction		
Head	316 SS	316 SS
Seals	Viton	Viton
Max. Temperature	180°F (82°C) (2)	180°F (82°C) (2)
Max. Pressure	800 psig (55 barg)	800 psig (55 barg)
Max. Differential Press.	60 psi (4.1 bar) (3)	60 psi (4.1 bar) (3)
Shipping Weight	16 lb. (7.3 kg)	20 lb. (9 kg)
Dimensions	4.0"D X 16"L (10cm X 41cm)	4.0"D X 27"L (10cm X 69cm)

### Ordering Information

For assistance, call toll-free at 1-800-343-4048 8AM to 5PM Eastern Time

Model	27/50	27/95
LP Filter Cartridges Depth Filters (4)	LP-200-50-□	LP-200-95-□
Number of Cartridges Required	1	1

#### Notes:

- 1 Adaptors are available which convert threaded ports to sanitary type clamp connections.
- 2 Limited by maximum temperature of LP Filter Cartridges.
- 3 Inside-out flow, LP filter cartridge.
- 4 To order filter cartridges, indicate grade by putting appropriate grade number after size designation. For example, to obtain 0.22 micron depth filter cartridges for the model 27/50, order LP-200-50-80.

# Liquid Filters

## 1/2" to 2" Line Size

### Model 33S6 and 45S6 Filters

All-stainless steel with 1/2" NPT inlet and outlet ports. Both filters are also available with clear Pyrex® glass bowl, 100 psig (6.9 barg) rating with breakage-protection external plastic shield.

#### Principal Specifications

Model	33S6	33G	45S6	45G
Port Size (NPT)	1/2" (1)	1/2" (1)	1/2" (1)	1/2" (1)
Material of Construction				
Head	316SS	316SS	316SS	316SS
Bowl	316SS	Pyrex	316SS	Pyrex
Internals	316SS	316SS	316SS	316SS
Seals	Viton	Viton	Viton	Viton
Max. Temperature	180°F (82°C) (2)	160°F (71°C) (2)	180°F (82°C) (2)	160°F (71°C) (2)
Max. Pressure	425 psig (29 barg) (3)	100 psig (6.9 barg) (3)	250 psig (17 barg) (3)	100 psig (6.9 barg) (3)
Max. Differential Press.	60 psi (4.1 bar) (4)	60 psi (4.1 bar) (4)	60 psi (4.1 bar) (4)	60 psi (4.1 bar) (4)
Shipping Weight	3 lb. (1.3 kg)	3 lb. (1.3 kg)	5 lb. (2.3 kg)	5 lb. (2.3 kg)
Dimensions	2.6"D x 4.8"L (7cm x 12cm)	2.6"D x 4.5"L (7cm x 11cm)	2.6"D x 9.0"L (7cm x 23cm)	2.6"D x 9.3"L (7cm x 23cm)



Models 33S6 and 45S6

Liquid  
Filters

#### Ordering Information

For assistance, call toll-free at 1-800-343-4048 8AM to 5PM Eastern Time

Model	33S6	33G	45S6	45G
LP Filter Cartridges, Depth Filters (5)	LP-100-12-□	LP-100-12-□	LP-100-25-□	LP-100-25-□
Number of Cartridges required	1	1	1	1

#### Notes:

- Adaptors are available which convert threaded ports to sanitary type clamp connections.
- Limited by maximum temperature of LP Filter Cartridges.
- Maximum pressure ratings are for temperatures to 200°F (93°C). Please consult the Technical Services Dept. for maximum pressure ratings at elevated temperatures.
- Inside-out flow, LP filter cartridges.
- To order filter cartridges, indicate grade by putting appropriate grade number after size designation. For example, to obtain 0.22 micron depth filter cartridges for the model 33S6, order LP-200-12-80.

#### Adaptor Ordering Information:

P/N 73803 1" NPT x 1"  
Sanitary  
P/N 73804 1 1/2" NPT x 1 1/2" Sanitary  
P/N 73805 2" NPT c 2"  
Sanitary

# Liquid Filters

## Disposable Filter Units for Liquids

Filter samples to on-line liquid analyzers

Prevent cross-contamination of samples

Pressure ratings up to 125 psig (8.6 barg)

Temperature to 275°F (135°C)

Completely disposable, constructed of recyclable plastics



Model  
9933-05



Model  
9922-11

### Disposable Filter Units

Balston Microfibre® Disposable Filter Unit (DFU) consists of a Microfibre Filter Cartridge permanently bonded into a sealed plastic holder with 125 psig (8.6 barg) pressure rating. The economical DFU offers all the advantages of Microfibre Filter Cartridges for high efficiency liquid filtrations, combined with the convenience of complete disposability. The 1/4" O.D. ports permit pressure-tight connections using standard compression fittings. Slip-on 1/4" tubing or plastic barbs may be used for low pressure applications.

The housings are available in two different materials of construction: clear nylon or corrosion-resistant (opaque) PVDF. The nylon DFU's are designated with the prefix 9933, and the PVDF DFU's are designated with the prefix 9922.

#### Model 9922-05

The Model 99XX-05 DFU's are the smallest DFU's available. They have an internal volume of less than 12 ml. the DFU's may be used in low flow liquid applications or sampling systems which require short retention times.

#### Model 9933-11

The Model 99XX-11 DFU's are similar in construction to the Model 99XX-05 DFU's, but they have approximately twice the solids holding capacity. The 99XX-11 DFU's may be used in higher flow liquid applications or in sampling applications where longer retention times are acceptable.

### Retention Efficiency Ratings

DFU Grade	98% retention particle size
DQ	25 micron
CQ	8 micron
BQ	2 micron
AQ	0.9 micron
AAQ	0.3 micron

# Liquid Filters

## Disposable Filter Units for Liquids

### Flow Rates

DFU Model	Volume of Housing Gallons Liters		Initial Pressure Drop	Water Flow Rate, Gallons (Liters) per Hour				
				Grade DQ, DX	Grade CQ, CX	Grade BQ, BX	Grade AQ	Grade AAQ
9922-05 4433-05 9933-05	0.003	0.01	1 psi (0.07 barg)	12 (45)	10 (38)	3 (11)	1.5 (5.7)	0.4 (1.5)
			5 psi (0.34 barg)	30 (114)	25 (95)	15 (57)	7.3 (28)	1.9 (7.2)
9922-11 9933-11	0.005	0.02	1 psi (0.07 barg)	18 (68)	15 (57)	5 (19)	2.5 (9.5)	0.6 (2.3)
			5 psi (0.34 barg)	45 (170)	37 (140)	26 (98)	12 (45)	3.1 (12)

Notes:

1 At 0 psig

2 At 110°F (43°C)

#### Installation Information:

Please contact the Technical Services Department for manufacturers of compression and brass fittings.

#### To Pressure Pipe or Tubing:

Connector 1/4" tubing to 1/4"NPT female  
P/N 11970 (1 per pkg)

Connector 1/4" tubing to 1/4" tubing

P/N 11971 (1 per pkg)

#### To Low Pressure Plastic Tubing:

Tubing with 1/4" ID may be slipped over the DFU and fittings and held with tubing clamps. Parker supplies plastic barbs to connect the DFU to smaller diameter plastic tubing. The connection is suitable for pressures to 50 psig (3.4 barg).

DFU to 1/16" ID tubing  
P/N 14000 (bag of 20 barbs)

DFU to 1/8" ID tubing  
P/N 14001 (bag of 20 barbs)

### Principal Specifications

Model	9922-05	9933-05	4433-05	9922-11	9933-11
Inlet and Outlet Ports	1/4" Tubing	1/4" Tubing	1 <sup>st</sup> Tier/Barb 1/4"Tubing 2 <sup>nd</sup> Tier/Barb 3/8"Tubing	1/4" Tubing	1/4" Tubing
Construction Material	PVDF	Nylon	Nylon	PVDF	Nylon
Max. Temperature (1)	275°F (135°C)	230°F (110°C)	230°F (110°C)	275°F (135°C)	230°F (110°C)
Max. Pressure	125 psig (8.6 barg) (2)	125 psig (8.6 barg) (2)	125 psig (8.6 barg) (2)	125 psig (8.6 barg) (2)	125 psig (8.6 barg) (2)
Dimensions	1.0"D x 3.25"L (2.5cm x 6cm)	1.0"D x 3.25"L (2.5cm x 6cm)	1.0"D x 3.43"L (2.5cm x 8.72cm)	1.4"D x 4.6"L (3.6cm x 12cm)	1.4"D x 4.6"L (3.6cm x 12cm)

### Ordering Information

For assistance, call toll-free at 1-800-343-4048 8AM to 5PM Eastern Time

Model	9922-05	9933-05	4433-05	9922-11	9933-11
Box of 10 DFUs	9922-05-□	9933-05-□	4433-05-□	9922-11-□	9933-11-□
Grades supplied	DQ, CQ, BQ, AQ, AAQ	DQ, CQ, BQ, AQ, AAQ	DQ, CQ, BQ, AQ, AAQ	DQ, CQ, BQ, AQ, AAQ	DQ, CQ, BQ, AQ, AAQ

### Chemical Compatibility

#### Models 9922-05, 9922-11

**Suitable:** Water or steam to 275°F (135°C); concentrated nitric, sulfuric, and hydrochloric acids; chlorine (gas or liquid); sodium hypochlorite, ethylene oxide (gas or liquid); Freons; ammonia (gas, liquid, or aqueous solutions); hydrogen peroxide (all concentrations); bromine (dry and aqueous solutions); all chlorinated solvents except methylene chloride; all aromatic and aliphatic solvents; all alcohols and glycols; aniline; phenol.

**Limited Use:** Acetone, MEK, dioxane, furfural, methylene chloride.

**Unsuitable:** Water above 275°F (135°C), THF, DMF, ethylene diamine, chlorosulfonic acid, ethanolamine, pyridine, sulfur trioxide.

#### Models 9933-05, 9933-11, 4433-05

**Suitable:** Water to 158°F (70°C); benzene, toluene, other aromatic hydrocarbons; hydrocarbon solvents and fuels, perchloroethylene; trichloroethylene, nitric acid (to 10%); sulfuric acid (to 40%); hydrochloric acid (to 10%); most salt solutions; sodium and potassium hydroxide (to 50%).

**Limited Use:** Water at 176°F (80°C); acetone; MEK, acetaldehyde; ammonia (to 25%).

**Unsuitable:** Water above 158°F (70°C). alcohols; glycols, phenol; aniline; DMF; concentrated acids; chlorine.

# Liquid Filters

## Water Filter

Remove contaminants to 5 micron

Prevent fixture discoloration

Materials comply with USFDA regulations

Constructed of non-corrosive materials

Ideal for drinking water systems

Inexpensive replacement filter cartridges

Transparent bowl for visual monitoring



Model  
57-501

Liquid  
Filters

### Balston Water Filter

The Balston 57-501 Series water filters provide economical, efficient liquid filtration in a one-step filter. These filters are designed to fit most 3/4" water supply lines and are available in three different efficiency ranges.

#### Retention Efficiency Ratings

Model	Retention efficiency Nominal µm rating	Water Flow Rate	
		5 psi	10 psi
57-501-C	80 (course grade)	15 GPM (57 lpm)	30 GPM (114 lpm)
57-501-M	30 (medium grade)	10 GPM (38 lpm)	20 GPM (76 lpm)
57-501-F	5 (fine grade)	8 GPM (30 lpm)	16 GPM (61 lpm)

#### Principal Specifications

Model	Materials of construction			Max. Press. (1)	Max. Temp.	Port Size	Shipping Weight	Dimensions
	Head	Bowl	Cartridge					
57-501-C	Polypro.	SAN	Polypro.	150 psi (10.3 bar)	125°F (52°C)	3/4" NPT	3.5 lbs. (1/6 kg)	5.5"D x 17"L (14cm x 43cm)
57-501-M	Polypro.	SAN	Polypro.	150 psi (10.3 bar)	125°F (52°C)	3/4" NPT	3.5 lbs. (1/6 kg)	5.5"D x 17"L (14cm x 43cm)
57-501-F	Polypro.	SAN	Polypro.	150 psi (10.3 bar)	125°F (52°C)	3/4" NPT	3.5 lbs. (1/6 kg)	5.5"D x 17"L (14cm x 43cm)

Notes:  
1 Maximum pressure at 70°F (21°C)

#### Ordering Information

For assistance, call toll-free at 1-800-343-4048 8AM to 5PM Eastern Time

Model	Replacement Filter Cartridges	
	Box of 3	Box of 10
57-501-C (Course grade)	WF-3/200-50-C	WF-200-50-C
57-501-M (Medium grade)	WF-3/200-50-M	WF-200-50-M
57-501-F (Fine grade)	WF-3/200-50-F	WF-200-50-F
Mounting Bracket Kit	P/N 11057	

# Filters for Steam Sterilization Systems

## Balston Steam Filters

The 23R Steam Filter contains a patented Microfibre® Filter Cartridge in a rugged stainless steel housing designed especially for steam service. Included as standard items with the 23R Steam Filter are a stainless steel condensate drain and a high quality bleeder valve. The unit, as received, is complete and ready for installation.



## Product Features

- Eliminate instrument staining, spotting, and rusting
- Reduced contamination of sterilizer interiors
- Reduced maintenance

Clean In Place (CIP) Steam Filtration



Room Humidification



Steam Filtration to Sterilizers and Autoclaves



# Steam Filters

## for Steam Sterilization Systems



Model 23/75R

### How the Balston Steam Filter Works

The 23/75R Steam Filter contains a patented Microfibre® Filter Cartridge in a rugged stainless steel housing designed especially for steam service. Included as standard items with the 23/75R Steam Filter are a stainless steel condensate drain and a high quality bleeder valve. The unit, as received, is complete and ready for installation.

Steam enters the housing and moves into an expansion chamber, where much of the condensate is removed from the steam by the abrupt change in flow direction and velocity. The steam then flows upward in the housing, through the Grade R Microfibre filter cartridge, and downward to the exit port. The water draining from the filter cartridges and expansion chamber is removed from the housing by the automatic condensate drain.

The Grade R Microfibre filter cartridge, the heart of the 23/75R Steam Filter, combines sturdy construction with remarkably efficient filtration of solid particles and liquid droplets. The cartridge is rated at 98+% at 0.1 micron. Solid particles remain trapped in the depth of the filter cartridge, and liquid water drips from the filter cartridge to the automatic drain. The Microfibre filter cartridge is constructed from chemically inert borosilicate glass fibers and fluorocarbon resin binder. The filter cartridge is completely free of impurities which could extract into the steam.

The Balston 23/75R Steam Filter is recommended for use on 3/4" and 1" steam lines (line sizes for the vast majority of steam sterilization systems). Please consult our technical support department for recommendations on filters for larger steam lines. Use only products designed specifically for steam filtration in steam installations.



# Steam Filters

## for Steam Sterilization Systems

### Principal Specifications

Model	Port Size	Filter Cartridge Designation	Materials of Construction			Seals	Maximum Steam Pressure	Shipping Weight
			Head	Bowl	Internals			
23/75R	1" NPT (1)	200-75-R (2)	304SS	304SS	304SS	EPR	80 psig (5.5 barg)	25 lbs. (11 kg)

### Ordering Information

For assistance, call toll-free at 1-800-343-4048 8AM to 5PM Eastern Time

Model	Automatic Drain	No. Filter Cartridges Required	Replacement Filter Cartridges (box of 15)
23/75R	Included	1	200-75-R

#### Notes:

1 The 1" port size can be installed in a 3/4" line by using the appropriate reducing bushings.

2 Each filter is supplied with one filter cartridge installed. Replacement filter cartridges are sold in boxes of 15. To order, use complete size and grade designation; for example 200-75-R.

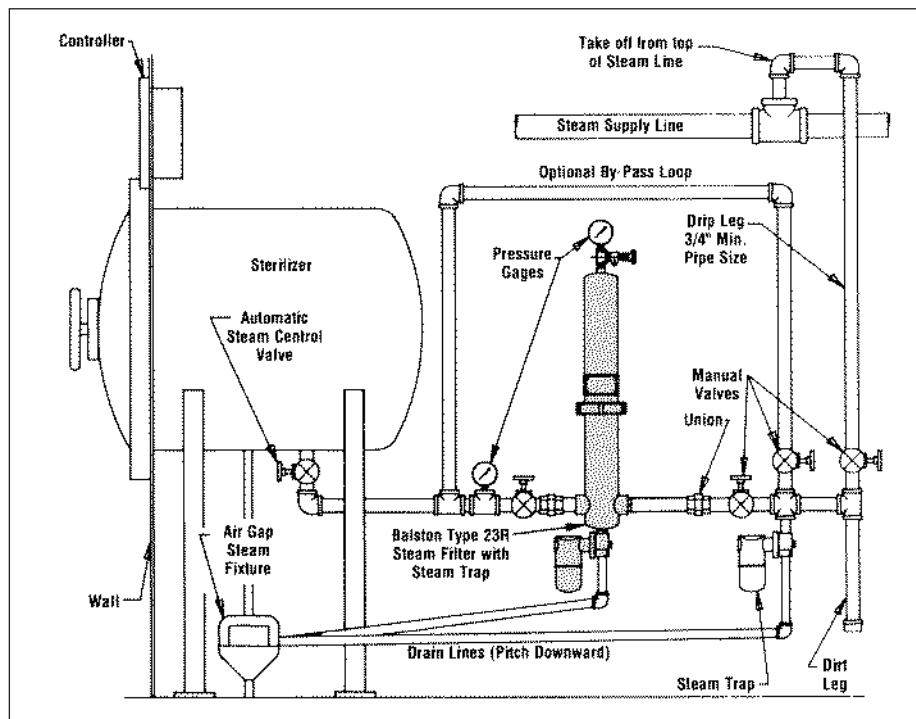

Typical Sterilizer  
Recommended Installation

# Steam Filters

## for Steam Sterilization Systems

### Water Filters for Washer Sterilizers

**Unique, graded efficiency design provides exceptionally long filter life**

**Reduces costly sterilizer maintenance**

**Easy to change filter cartridge - no tools required**

**Safe, inert materials of construction**

#### Filtering Water with the Balston LP-20 Water Filter

Dirt and rust in the hot or cold water supply to washer-sterilizers leave deposits and stains on valuable instruments and sterilizers. In most hospitals, the cleanliness of the water depends upon the efficiency of the municipal water treatment system. Excessive dirt in the water can be an intermittent problem caused by a drought, a fire in the neighborhood, water main problems, or scores of other random events well beyond the control of the hospital engineers. This unpredictable, expensive problem can be permanently solved by installing an inexpensive and easily maintained Balston LP Grade 20 water filter on the water line to the washer-sterilizer. On any washer-sterilizer, installing a Balston 23/75R Steam Filter on the steam line and a Balston LP Grade 20 Water Filter on the water line guarantees freedom from the outside contaminants.

#### How the cartridge works

The LP Grade 20 liquid filter cartridge is constructed entirely from polypropylene, rendering it safe and inert for use in hospital water supplies. The polypropylene construction makes this filter acceptable for use in cold and hot (to 180°F/82°C) water supplies. The filter cartridge consists of a polypropylene external support structure with EPR seals and an internal filtering element. The internal filter is made of self-bonded polypropylene fibers which are graded from coarse to fine in the direction of flow (inside-to-outside). Since the coarse inner layer acts as a prefilter for the finer outer layer, the life of this cartridge is exceptionally long. For example: Approximately 50,000 gallons (190,000 liters) of water can be filtered by a single 20" liquid filter cartridge.



Model 53/50



Model 53/95

#### Filter Assembly Selection Recommendations

Water Line Size	Cold Water below 125°F (52°C)
3/4"	53/95 with LP-200-95-20
1/2"	53/50 with LP-200-50-20

#### Models 53/50 and 53/95

These models are constructed entirely of polypropylene and designed for a single filter cartridge in the 10" and 20" lengths. The Model 53 housings are used for cold water service only.

# Steam Filters

## for Steam Sterilization Systems

## Water Filters for Washer Sterilizers

### Principal Specifications

Model	Port Size	Materials of Construction			Seals	Maximum Temperature	Maximum Pressure	Maximum Diff. Press. (1)	Shipping Weight	Dimensions
		Head	Bowl	Internals						
<b>COLD WATER FILTER</b>										
53/50	3/4" NPT	Polypro.	Polypro.	—	EPR	125°F (52°C)	125 psig (8.6 barg)	60 psig (4.1 barg)	4 lbs (2 kg)	5"D x 12"L (13cm x 31cm)
53/95	3/4" NPT	Polypro.	Polypro.	—	EPR	125°F (52°C)	125 psig (8.6 barg)	60 psig (4.1 barg)	6 lbs (3 kg)	5"D x 22"L (13cm x 56cm)

### Ordering Information

For assistance, call toll-free at 1-800-343-4048 8AM to 5PM Eastern Time

Model	No. Filter Cartridges Required (2)	Filter Cartridge Designation
53/50	1	LP-200-50-20
53/95	1	LP-200-95-20

Notes:

- 1 LP Grade 20 Filter Cartridge. Inside-to-outside flow.
- 2 Filter Cartridge not included with housing and must be ordered separately.

# Steam Filters

## for Steam Sterilization Systems

### EtO Filters

Long filter life

Easy to change filter cartridge

Eliminate unexpected downtime due to clogged components

Stainless steel and PTFE provide safe, trouble-free operation



Model A34

#### Model A34

The cleanliness of Ethylene Oxide (EtO) typically varies from supplier to supplier and from delivery to delivery. In addition, EtO inherently polymerizes, causing valves to clog and regulators to malfunction. Filtering EtO at the point of use assures the delivery of clean EtO to the sterilizers, significantly improves sterilizer performance, and reduces sterilizer maintenance.

Balston EtO Filters, specifically designed for ethylene oxide service, are constructed of stainless steel with PTFE seals. The ET Grade 30 filter cartridge is inexpensive and simple to replace when necessary.

The model A34 is sized for most hospital sterilizer applications.

Steam Filters

#### Principal Specifications

Model	Port Size	Filter Cartridge Designation	Materials of Construction			Internals	Seals	Maximum Steam Pressure	Shipping Weight
			Head	Bowl					
A34	1/4" NPT	ET-100-12-30 (1)	316SS	316SS	316SS	PTFE (2)	250 psig (17 barg)	4 lbs. (2 kg)	

#### Ordering Information

For assistance, call toll-free at 1-800-343-4048 8AM to 5PM Eastern Time

Model	Filter Cartridge Designation
A34 Included	ET-100-12-30

Notes:

1 Each filter is supplied with one filter cartridge installed.

2 Each filter is supplied with one spare PTFE seal set.

# Natural Gas Filters

## Balston Compressed Gas Filters

Balston high flow rate compressed gas filters offer exceptionally high efficiency coalescing filtration of compressed gas at high flow rates. Specifically designed to remove suspended liquids and dirt from pipeline natural gas, the housings are ASME Code Stamped up to 1440 psig (100 barg). Equipped with Balston Microfibre® Grade DX Disposable Filter Cartridges, the filters are rated at 93% retention of 0.01 micron.



## Product Features

- Pressure rating to 1440 psig (100 barg)
- Meets US and Canadian codes for natural gas filters
- Flow rates to 183 million standard cubic feet per day
- High efficiency removal of suspended liquid and solid impurities

Sample and Instrumentation Filtration



High Pressure Process Gas Filtration



Stainless Steel Filtration Vessels for Corrosive Environments



High Volume Gas Filtration



# Natural Gas Filters

## 2" Through 10" Line Size Filters



Model AKH-0280



Model AKH-0880

### Balston Compressed Gas Filters

Balston high flow rate compressed gas filters offer exceptionally high efficiency coalescing filtration of compressed gas at high flow rates. Specifically designed to remove suspended liquids and dirt from pipeline natural gas, the housings are ASME Code Stamped up to 1440 psig. Equipped with Balston Microfibre® Grade DX Disposable Filter Cartridges, the filters are rated at 93% retention of 0.01 micron and essentially 100% retention of 5 micron liquid droplets and particles.

Since the coalesced liquid drains continuously from the filter cartridges as rapidly as it is collected, the filters have an unlimited capacity for liquid removal.

Each filter cartridge is mounted on a rigid permanent filter holder with a vibration-resistant removable tube retainer. The filter cartridge is self-gasketing, and the filter holder is designed so that a perfect seal is easily made, even when the tube is replaced by an operator unfamiliar with the equipment.

Series AKH, and AHC housings are available with inlet and outlet ports covering the range from 2" to 10" pipe sizes. The standard carbon steel units have pressure ratings from 665 to 1440 psig (46 to 99 barg).

Each AHC assembly is equipped with internal support cores and one set of filter cartridges. Also available is a complete line of stainless steel filter housings ASME code stamped for a rated maximum operating pressure of 200 psig (14 barg).

# Natural Gas Filters

## 2" Through 4" Line Size Filters

### Principal Specifications

Model	Port Size Flange (7)	Closure Type*	Maximum Temperature (3)	Maximum Pressure (1)	Shipping Weight	Dimensions (7, 10)	Flange to Flange Dimension
15/80S6	2"	SS	400°F (204°C)	800 psig (35 barg)	32 lbs.(44 kg)	6.3"D X 28"L (16 cm X 71 cm)	—
AHC-0180-[ ]	2"	SD	130°F (54°C)	1440 psig (99 barg)	98 lbs.(14.4 kg)	32"H x 15"W x 4.5" (81cm x 38cm x 11cm)	14.5" (37cm)
AKH-0280-[ ]	3"	FSO	250°F (121°C)	665 psig (46 barg)	235 lbs.(107 kg)	41"H x 16"W x 8" (104cm x 41cm x 20cm)	15.63" (40cm)
AHC-0280-[ ]	3"	SD	130°F (54°C)	1440 psig (99 barg)	220 lbs.(100 Kg)	43"H x 17"W x 12" (109cm x 43cm x 30cm)	16.63" (42cm)
AKH-0480-[ ]	4"	FSO	250°F (121°C)	665 psig (46 barg)	270 lbs.(122 kg)	40"H x 21"W x 6" (102cm x 53cm x 15cm)	20.63" (52cm)
AHC-0480-[ ]	4"	SD	130°F (54°C)	1440 psig (99 barg)	450 lbs.(204 kg)	50"H x 21"W x 15" (127cm x 53cm x 38cm)	20.63" (52cm)

Model	Port Size Flange (12)	Materials of Construction	Maximum Temperature	Maximum Pressure (9)	Shipping Weight	Dimensions (7, 10)	Flange to Flange Dimension
KS-0280-3	3"	316SS Housing, Viton Seals	200°F (93°C)	200 psig (14 barg)	140 lbs.	36"h x 15.6"w x 7.75" (91cm x 40cm x 20cm)	15.62" (40cm)
KS-0480-4	4"	316SS Housing, Viton Seals	200°F (93°C)	200 psig (14 barg)	210 lbs.	35.5"h x 20.6"w x 6.25" (90cm x 52cm x 16cm)	20.63" (52cm)

#### Notes

- Vessel is ASME Section VIII, Div. 1 code stamped for rated pressure.
- All vessels are constructed of carbon steel with Type 303 stainless steel filter cartridge holders and Buna-N seals.
- Maximum operating temperature of carbon steel vessel is 650°F (343°C). Minimum operating (process and ambient) temperature is -20°F (-30°C).

#### Max. Temp.

- 250°F (121°C)
- 400°F (204°C)
- 500°F (260°C)

#### Seal Material

- Buna
- Viton
- Silicone

4 Model 20-211 drain is installed on all AKS housings. Maximum operating pressure for the 20-211 drain is 400 psig (28 barg).

5 Differential Pressure Indicator and Auto-

matic Drain are not included with AHC and AKH Assemblies. Series AHC Assemblies are equipped with internal support cores and one set of filter cartridges.

6 ANSI Flange Classes:

- AKH Series: 300 lbs. (136 kg) R.F.S.O.
- AHC Series: 600 lbs. (273 kg) R.F.S.O.

7 Dimensions are height x width x center of flange-to-floor height.

\*Closure Abbreviations:

SD: Screw type closure with Buna N "O" ring

FSO: Flat (flanged) top with swing bolts and Buna N "O" ring.

### Ordering Information

For assistance, call toll-free at 1-800-343-4048 8AM to 5PM Eastern Time

Model	Automatic Float Drain	Differential Pressure Indicator (5)	Filter Cartridges No. Required	Box of 10 Cartridges (8)
15/80S6	—	—	—	200-80-□
AHC-0180-DX	—	—	1	200-80-DX
AKH-0280-DX	20-211 (13)	—	2	200-80-DX
AHC-0280-DX	—	—	2	200-80-DX
AKH-0480-DX	20-211 (13)	—	4	200-80-DX
AHC-0480-DX	—	—	4	200-80-DX
AKS-0280-DX	20-211 or 20-440 (13)	—	2	200-80-□
AKS-0480-DX	20-211 or 20-440 (13)	—	4	200-80-□

#### Notes:

8 To order filter cartridges, indicate Grade by putting appropriate letters after size designation. For example, to order Grade DX cartridges for KS-0280-3 housing, order 200-80-DX. Microfibre Filter Cartridges are sold in boxes of 10.

9 Vessel is ASME Section VIII, Division 1 code stamped for rated pressure at 200°F (93°C). Maximum pressure ratings are for temperatures to 200°F (93°C). Please consult factory for maximum pressure ratings at elevated temperatures.

10 All dimensions are approximate. Request certified drawing for installation dimensions.

11 Requires element retainer #27900, one for each cartridge. Order separately.

12 All flanges are ANSI 150#RFSSO.

13 20-211 Auto Float Drain, 20-440 Auto Electric Solenoid Drain.

# Natural Gas Filters

## 6" Through 10" Line Size Filters

### Principal Specifications

Model	Port Size Flange (7)	Closure Type*	Maximum Temperature (3)	Maximum Pressure (1)	Shipping Weight	Dimensions (8)	Flange to Flange Dimension
AKH-0880-[ ]	6"	FSO	250°F (121°C)	665 psig (46 barg)	560 lbs.(254 kg)	43"h x 25"w x 8.5" (109cm x 64cm x 22cm)	24.75" (63cm)
AHC-0880-[ ]	6"	SD	130°F (54°C)	1440 psig (99 barg)	980 lbs.(445 kg)	54"h x 25"w x 18" (137cm x 64cm x 46cm)	24.75" (63cm)
AKH-1480-[ ]	8"	FSO	250°F (121°C)	665 psig (46 barg)	1120 lbs.(508 kg)	54"h x 34"w x 16" (137cm x 86cm x 41cm)	34" (86cm)
AKH-2280-[ ]	10"	FSO	250°F (121°C)	665 psig (46 barg)	1430 lbs.(649 kg)	57"h x 36"w x 17" (145cm x 91cm x 43cm)	36" (91 cm)

Model	Port Size Flange (13)	Materials of Construction	Maximum Temperature	Maximum Pressure (10)	Shipping Weight	Dimensions (8, 11)	Flange to Flange Dimension
AKS-0880-[ ]	6"	316SS Housing, Viton Seals	200°F (93°C)	200 psig (14 barg)	360 lbs.(163 kg)	38"h x 24.75"w x 7.5" (97cm x 63cm x 19cm)	24.75" (63cm)
AKS-1480-[ ]	8"	316SS Housing, Viton Seals	200°F (93°C)	200 psig (14 barg)	590 lbs.(268 kg)	54"h x 34"w x 16.25" (137cm x 86cm x 41cm)	34" (86cm)
AKS-2280-[ ]	10"	316SS Housing, Viton Seals	200°F (93°C)	200 psig (14 barg)	880 lbs.(400 kg)	56"h x 36"w x 17.25" (142cm x 91cm x 44cm)	36" (91cm)

### Ordering Information

For assistance, call toll-free at 1-800-343-4048 8AM to 5PM Eastern Time

Model	Automatic Float Drain	Differential Pressure Indicator (5)	Filter Cartridges No. Required	Box of 10 Cartridges
AKH-0880-DX	—	—	8	200-80-DX
AHC-0880-DX	—	—	8	200-80-DX
AKC-1480-DX	20-211	41-071	14	200-80-DX
AKC-2280-DX	20-211	41-071	22	200-80-DX
AKS-0880-DX or BX	20-211 or 20-440 (14)	—	8	200-80-DX or BX
AKS-1480-DX or BX	20-211 or 20-440 (14)	—	14	200-80-DX or BX
AKS-2280-DX or BX	20-211 or 20-440 (14)	—	22	200-80-DX or BX



# Natural Gas Filters

## Flow Rates

### High Pressure Filter Housings

#### Flow Rate at 2 psi (0.14 bar) Drop at Indicated Line Pressure with 200-80-DX filter Cartridges

Assembly	40 psig (3 bar)		100 psig (7 bar)		200 psig (14 bar)		400 psig (28 bar)		600 psig (41 bar)		1000 psig (69 bar)		1400 psig (97bar)	
	MM SCFD (MNm <sup>3</sup> /hr)	SCFM (Nm <sup>3</sup> /min)	MM SCFD (MNm <sup>3</sup> /hr)	SCFM (Nm <sup>3</sup> /min)	MM SCFD (MNm <sup>3</sup> /hr)	SCFM (Nm <sup>3</sup> /min)	MM SCFD (MNm <sup>3</sup> /hr)	SCFM (Nm <sup>3</sup> /min)	MM SCFD (MNm <sup>3</sup> /hr)	SCFM (Nm <sup>3</sup> /min)	MM SCFD (MNm <sup>3</sup> /hr)	SCFM (Nm <sup>3</sup> /min)	MM SCFD (MNm <sup>3</sup> /hr)	SCFM (Nm <sup>3</sup> /min)
AHC-0180	0.8 (0.02)	595 (16.9)	1.8 (0.05)	1250 (35.4)	3.3 (0.09)	2340 (66.3)	6.5 (0.18)	4515 (128)	9.4 (0.27)	6700 (190)	15.9 (0.45)	11050 (313)	22.2 (0.63)	15400 (436)
AKH-0280* AHC-0280	1.7 (0.05)	1190 (33.7)	3.6 (0.10)	2500 (70.8)	6.7 (0.19)	4680 (133)	13.0 (0.37)	9030 (256)	19.2 (0.54)	13400 (379)	31.8 (0.90)	22100 (626)	44.4 (1.26)	30800 (872)
AKH-0480* AHC-0480	3.5 (0.10)	2430 (68.8)	7.3 (0.21)	5100 (144)	13.8 (0.39)	9550 (270)	26.5 (0.75)	18400 (521)	39.5 (1.12)	27300 (773)	64.9 (1.84)	45100 (1277)	90.5 (2.56)	62900 (1781)
AKH-0880* AHC-0880	7.0 (0.20)	4910 (139)	14.8 (0.42)	10300 (292)	27.8 (0.79)	19300 (547)	53.6 (1.52)	37200 (1054)	79.5 (2.25)	55200 (1563)	131 (3.71)	91100 (2580)	183 (5.18)	127000 (3597)
AKH-1480*	12.3 (0.35)	8580 (243)	25.9 (0.73)	18000 (510)	48.5 (1.73)	33700 (954)	93.6 (2.65)	65050 (1842)	139 (3.94)	96400 (2730)	—	—	—	—
AKH-2280*	19.2 (0.54)	13350 (378)	40.3 (1.14)	28000 (793)	75.4 (2.14)	52400 (1484)	145 (4.11)	101000 (2860)	216 (6.12)	150000 (425)	—	—	—	—

MM SCFD = Million Standard Cubic Feet per Day MSm<sup>3</sup>/d = Million Standard Cubic Meters per Day

SCFM = Standard Cubic Feet per Minute Sm<sup>3</sup> = Cubic Meters per Minute

\*Note: AKH Series Rated to 665 psig

### Stainless Steel Filter Housings

#### Flow Rate SCFM (Nm<sup>3</sup>/min) at 2 psi Drop at Indicated Line Pressure

Assembly	Grade	2 psig (0.14 barg)	20 psig (1.4 barg)	60 psig (4.1 barg)	80 psig (5.5 barg)	100 psig (6.9 barg)	150 psig (10 barg)	200 psig (14 barg)
AKS-0280	DX	364 (10)	760 (22)	1630 (44)	2065 (58)	2500 (71)	3600 (102)	4680 (133)
	BX	90 (3)	190 (5)	400 (11)	510 (14)	620 (18)	890 (25)	1160 (33)
AKS-0480	DX	760 (22)	1540 (44)	3320 (94)	4210 (119)	5100 (144)	7300 (207)	9550 (270)
	BX	180 (5)	380 (11)	810 (23)	1025 (29)	1240 (35)	1780 (50)	2320 (66)
AKS-0880	DX	1500 (42)	3120 (88)	6710 (190)	8505 (241)	10300 (92)	14800 (419)	19300 (547)
	BX	360 (10)	750 (21)	1620 (46)	2050 (58)	2480 (70)	3560 (101)	4640 (131)
AKS-1480	DX	2620 (74)	5450 (154)	11720 (332)	14860 (421)	18000 (510)	25800 (731)	33700 (954)
	BX	630 (18)	1310 (37)	2830 (80)	3585 (102)	4340 (23)	6230 (176)	8120 (230)
AKS-2280	DX	4080 (116)	8470 (240)	18230 (516)	23115 (655)	28000 (793)	40200 (1138)	52400 (1484)
	BX	1000 (28)	2070 (59)	4460 (126)	5655 (160)	6850 (94)	9840 (279)	12800 (362)

Natural Gas  
Filters

# Natural Gas Filters

## Low Pressure Natural Gas Filters

### New LF/FF Series Multiple Cartridge Filter Assemblies

These filter assemblies provide high efficiency filtration of gas at very high flow rates. With inlet and outlet ports accommodating 3" to 10" pipe sizes, the new LF/FF Series housings are capable of flow rates up to a maximum capacity of 37,350 SCFM (63,450 m<sup>3</sup>/h) at 100 psig (7 barg). The standard carbon steel units, which are generally in stock (through 6" line sizes), have pressure ratings up to 250 psig.



All LF/FF series housings are ASME Code Stamped for the rated maximum operating pressure. All FF Series vessels have built-in legs for floor mounting. Selected models have swing bolt enclosures for easy access to the internals. The filter cartridges in all models are sealed by tightening the threaded retainer cap onto the rigid tie rod, ensuring a leak tight seal on both ends of the cartridge.

Each assembly is equipped with a carbon steel automatic float drain, differential pressure indicator, and a set of filter cartridges (except where noted).

**NEW!**

### High Flow Coalescing Filter Media HFC Grade

**Efficiency: 99.5% @ 0.5 micron**

Balston's HFC media consists of two layers. The outer layer features a dense matrix of glass fibers. It provides highly efficient coalescing aerosol removal and very low pressure drop. The inner layer, or initial stage of filtration, effectively traps dirt particles, protecting and extending the life of the outer layer. A metal retainer is used for strength and stability. This media is used in bulk coalescing applications and when relatively high efficiency and low pressure drop are required.



### High Efficiency Coalescing Media HEC Grade

**Efficiency: 99.97% @ 0.01 micron**

Air Flow: Inside to Outside

This coalescing element is composed of an epoxy saturated borosilicate glass micro-fiber tube. The HEC grade filter has a pleated cellulose inner layer as a built-in prefilter. This element is metal retained for added strength, and includes a synthetic fabric layer.

HEC filters are used when "total removal of liquid aerosols and suspended fines" is required. Because of its overall performance characteristics, this grade is most often recommended.



Natural Gas  
Filters

### Benefits

- |                                     |                                    |
|-------------------------------------|------------------------------------|
| <i>Low Pressure Drop</i>            | <i>Heat and Chemical Resistant</i> |
| <i>Lower Change out/Labor Costs</i> | <i>No Wet Zone</i>                 |
| <i>Lower Energy Costs</i>           | <i>Oleophobic/Hydrophobic</i>      |
| <i>High Dirt Holding Capacity</i>   | <i>High Burst Strength</i>         |

# Natural Gas Filters

## Low Pressure Natural Gas Filters

**HFC MEDIA Max. Rated Flows SCFM at Various Operating Pressures  
(0.25 psi pressure drop)**

Model Number	2 PSIG	20 PSIG	40 PSIG	80 PSIG	100 PSIG	125 PSIG	150 PSIG	175 PSIG	200 PSIG	220 PSIG	250 PSIG
ALN3-0128-HFC	363	753	1187	2056	2490	3033	3575	4118	4661	5095	5746
ALF3-0128-HFC	363	753	1187	2056	2490	3033	3575	4118	4661	5095	5746
ALF4-0125-HFC	483	1004	1583	2741	3320	4044	4767	5491	6215	6793	N/A
ALF6-0136-HFC	725	1507	2375	4112	4980	6065	7151	8236	9322	10190	N/A
ALF6-0336-HFC	1088	2260	3562	6167	7470	9098	10726	12354	13983	15285	N/A
AFN3-0128-HFC	363	753	1187	2056	2490	3033	3575	4118	4661	5095	5746
AFF3-0128-HFC	363	753	1187	2056	2490	3033	3575	4118	4661	5095	5746
AFF4-0125-HFC	483	1004	1583	2741	3320	4044	4767	5491	6215	6793	N/A
AFF6-0136-HFC	725	1507	2375	4112	4980	6065	7151	8236	9322	10190	11493
AFF6-0328-HFC	1088	2260	3562	6167	7470	9098	10726	12354	13983	15285	N/A
AFF8-0428-HFC	1450	3013	2464	8223	9960	12131	14302	16472	18644	20380	22984
AFF10-0728-HFC	2538	5273	8312	14391	17430	21229	25028	28826	32627	35665	40222
AFF12-1128-HFC	3988	8286	13062	22614	27390	33360	39330	45298	51271	56045	63206
AFF16-1528-HFC	5438	11299	17812	30837	37350	45491	53632	61770	69915	76425	86190

**HEC MEDIA Max. Rated Flows SCFM at Various Operating Pressures  
(1.5 psi pressure drop)**

Model Number	2 PSIG	20 PSIG	40 PSIG	80 PSIG	100 PSIG	125 PSIG	150 PSIG	175 PSIG	200 PSIG	220 PSIG	250 PSIG
ALN3-0128-HEC	218	454	715	1238	1500	1827	2154	2481	2808	3069	3462
ALF3-0128-HEC	218	454	715	1238	1500	1827	2154	2481	2808	3069	3462
ALF4-0125-HEC	219	605	954	1651	2000	2436	2872	3308	3744	4092	N/A
ALF6-0136-HEC	437	908	1431	2477	3000	3654	4308	4962	5616	6139	N/A
ALF6-0328-HEC	654	1362	2145	3714	4500	5481	6462	7443	8424	9207	N/A
AFN3-0128-HEC	218	454	715	1238	1500	1827	2154	2481	2808	3069	3462
AFF3-0128-HEC	218	454	715	1238	1500	1827	2154	2481	2808	3069	3462
AFF4-0125-HEC	291	605	954	1651	2000	2436	2872	3308	3744	4092	N/A
AFF6-0136-HEC	437	908	1431	2477	3000	3654	4308	4962	5616	6139	6923
AFF6-0328-HEC	654	1362	2145	3714	4500	5481	6462	7443	8424	9207	N/A
AFF8-0428-HEC	872	1816	2860	4952	6000	7308	8616	9924	11232	12276	13848
AFF10-0728-HEC	1526	3178	5005	8666	10500	12789	15078	17367	19656	21483	24234
AFF12-1128-HEC	2398	4994	7865	13618	16500	20097	23694	27291	30888	33759	38082
AFF16-1528-HEC	3270	6810	10725	18570	22500	27405	32310	37215	42120	46035	51930

Natural Gas  
Filters

# Natural Gas Filters

## Low Pressure Natural Gas Filters

**HFC MEDIA Max. Rated Flows Nm<sup>3</sup>/hr at Various Operating Pressures  
(0.02 bar pressure drop)**

Model Number	0.14 barg	1.4 barg	2.8 barg	5.5 barg	6.9 barg	8.6 barg	10 barg	12 barg	14 barg	15 barg	17 barg
ALN3-0128-HFC	617	1279	2017	3493	4231	5153	6074	6996	7919	8656	9762
ALF3-0128-HFC	617	1279	2017	3493	4231	5153	6074	6996	7919	8656	9762
ALF4-0125-HFC	821	1706	2690	4657	5641	6871	8099	9329	10559	11541	N/A
ALF6-0136-HFC	1232	2560	4035	6986	8461	10304	12150	13993	15838	17313	N/A
ALF6-0336-HFC	1849	3840	6052	10478	12692	15458	18223	20989	23757	25969	N/A
AFN3-0128-HFC	617	1279	2017	3493	4231	5153	6074	6996	7919	8656	9762
AFF3-0128-HFC	617	1279	2017	3493	4231	5153	6074	6996	7919	8656	9762
AFF4-0125-HFC	821	1706	2690	4657	5641	6871	8099	9329	10559	11541	N/A
AFF6-0136-HFC	1232	2560	4035	6986	8461	10304	12150	13993	15838	17313	19527
AFF6-0328-HFC	1849	3840	6052	10478	12692	15458	18223	20989	23757	25969	N/A
AFF8-0428-HFC	2464	5119	8070	13971	16922	20611	24299	27989	31676	34626	39050
AFF10-0728-HFC	4312	8959	14122	24450	29614	36068	42523	48975	55433	60595	68337
AFF12-1128-HFC	6776	14078	22192	38421	46536	56679	66822	76961	87109	95220	107387
AFF16-1528-HFC	9239	19197	30263	52392	63458	77289	91121	104947	118786	129846	146437

**HEC MEDIA Max. Rated Flows Nm<sup>3</sup>/hr at Various Operating Pressures  
(0.1 bar pressure drop)**

Model Number	0.14 barg	1.4 barg	2.8 barg	5.5 barg	6.9 barg	8.6 barg	10 barg	12 barg	14 barg	15 barg	17 barg
ALN3-0128-HEC	370	771	1215	2103	2549	3104	3660	4215	4771	5214	4183
ALF3-0128-HEC	370	771	1215	2103	2549	3104	3660	4215	4771	5214	4183
ALF4-0125-HEC	372	1028	1621	2805	3398	4139	4880	5620	6361	6952	N/A
ALF6-0136-HEC	742	1543	2431	4208	5097	6208	7319	8430	9542	10430	N/A
ALF6-0328-HEC	1111	2314	3466	6310	7646	9312	10979	12646	14312	15643	N/A
AFN3-0128-HEC	370	771	1215	2103	2549	3104	3660	4215	4771	5214	4183
AFF3-0128-HEC	370	771	1215	2103	2549	3104	3660	4215	4771	5214	4183
AFF4-0125-HEC	494	1028	1621	2805	3398	4139	4880	5620	6361	6952	N/A
AFF6-0136-HEC	742	1543	2431	4208	5097	6208	7319	8432	9542	10430	11762
AFF6-0328-HEC	1111	2314	3644	6310	7646	9312	10979	12646	14312	15643	N/A
AFF8-0428-HEC	1482	3085	4859	8413	10194	12416	14639	16861	19083	20857	23528
AFF10-0728-HEC	2593	5399	8503	14724	17840	21729	25618	29507	33396	36500	41174
AFF12-1128-HEC	4074	8485	13363	23137	28034	34145	40256	46367	52479	57357	64701
AFF16-1528-HEC	5556	11570	18222	31550	38228	46561	54895	63228	71562	78213	88229

Natural Gas Filters

### Housing Selection Chart

Model Number	HFC Replacement Element	HEC Replacement Element	Port Size	Port Type	# of Elements
<b>LINE MOUNT VESSELS</b>					
ALN3-0128-H?C	510-28- HFC	510-28-HEC	3	NPT	1
ALF3-0128-H?C	510-28- HFC	510-28- HEC	3	FLANGE	1
ALF4-0125-H?C	850-25- HFC	850-25- HEC	4	FLANGE	1
ALF6-0136-H?C	850-36- HFC	850-36- HEC	6	FLANGE	1
ALF6-0328-H?C	510-28- HFC	510-28- HEC	6	FLANGE	3
<b>FLOOR MOUNT VESSELS</b>					
AFN3-0128-H?C	510-28- HFC	510-28- HEC	3	NPT	1
AFF3-0128-H?C	510-28- HFC	510-28- HEC	3	FLANGE	1
AFF4-0125-H?C	850-25- HFC	850-25- HEC	4	FLANGE	1
AFF6-0136-H?C	850-36- HFC	850-36- HEC	6	FLANGE	1
AFF6-0328-H?C	510-28- HFC	510-28- HEC	6	FLANGE	3
AFF8-0428-H?C	510-28- HFC	510-28- HEC	8	FLANGE	4
AFF10-0728-H?C	510-28- HFC	510-28- HEC	10	FLANGE	7
AFF12-1128-H?C	510-28- HFC	510-28- HEC	12	FLANGE	11
AFF16-1528-H?C	510-28- HFC	510-28- HEC	16	FLANGE	15

# Natural Gas Filters

## Drawings, Dimensions & Specifications

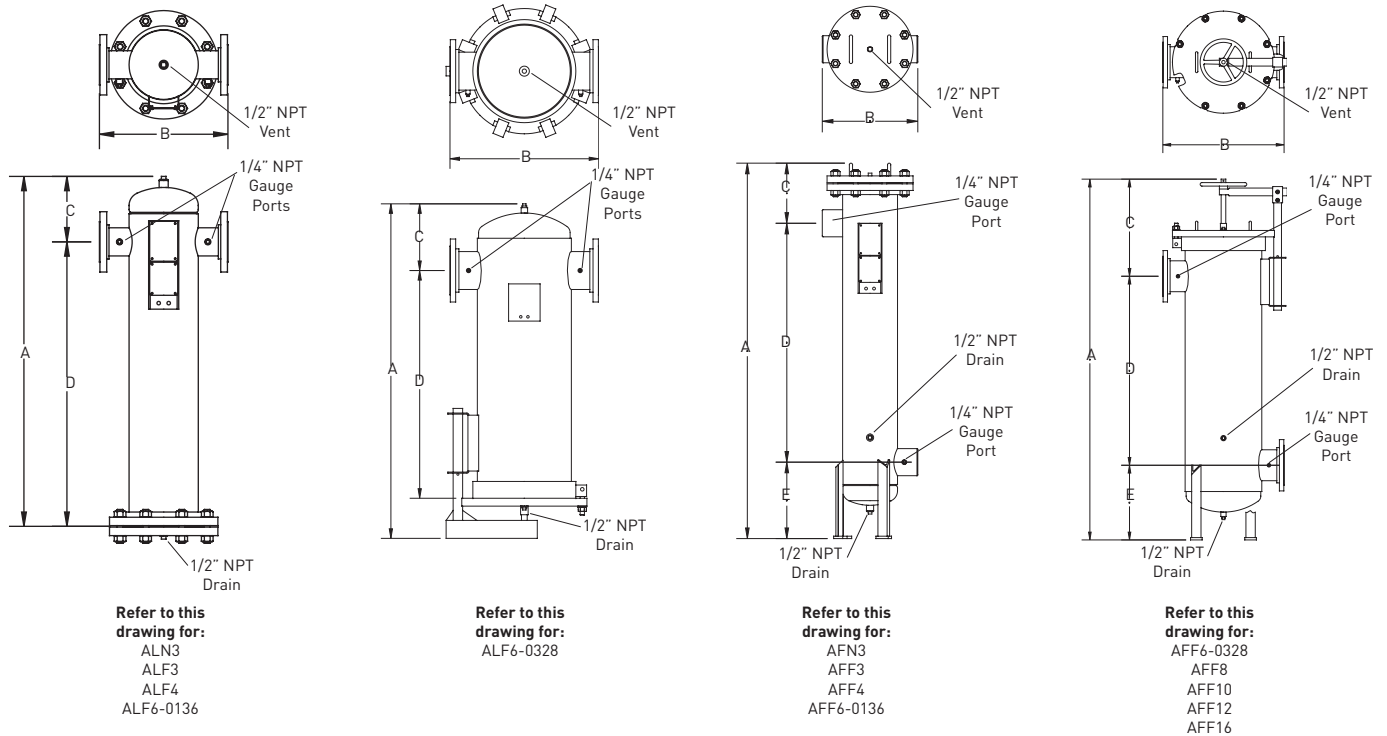

Dimensions	A	B	C	D	E	Element Removal Clearance inches (centimeters)	Sump Capacity gallons (liters)	Weight pounds (kilograms)
ALN3	43.1 (109.5)	15.0 (38.1)	7.7 (19.5)	35.4 (89.9)	—	28 (71.1)	0.81 (3)	190 (86)
ALF3	43.1 (109.5)	16.0 (40.6)	7.7 (19.5)	35.4 (89.9)	—	28 (71.1)	0.81 (3)	190 (86)
ALF4	42.7 (108.5)	20.0 (50.8)	9.7 (24.6)	33.0 (83.8)	—	25 (63.5)	2.0 (7)	380 (173)
ALF6-0136	56.4 (143.3)	20.0 (50.8)	11.4 (29.0)	45.0 (114.3)	—	36 (91.4)	2.0 (7)	380 (173)
ALF6-0328	57.8 (146.8)	26.0 (66.0)	11.0 (27.9)	39.8 (101.1)	—	28 (71.1)	2.0 (7)	340 (155)
AFN3	58.9 (149.6)	15.0 (38.1)	9.4 (23.8)	37.5 (95.2)	12.0 (30.4)	28 (71.1)	1.1 (4)	190 (86)
AFF3	58.9 (149.6)	16.0 (40.6)	9.4 (23.8)	37.5 (95.2)	12.0 (30.4)	28 (71.1)	1.2 (4)	200 (91)
AFF4	63.3 (160.7)	20.0 (50.8)	12.3 (31.2)	35.0 (88.9)	16.0 (40.6)	25 (63.5)	4.2 (16)	370 (168)
AFF6-0136	75.3 (191.2)	20.0 (50.8)	12.3 (31.2)	47.0 (119.3)	16.0 (40.6)	36 (91.4)	3.6 (14)	410 (186)
AFF6-0328	77.3 (196.3)	26.0 (66.0)	20.8 (52.8)	40.5 (102.8)	16.0 (40.6)	28 (71.1)	5.0 (19)	340 (155)
AFF8	87.3 (221.7)	30.0 (76.2)	25.8 (65.5)	42.5 (108.0)	19.0 (48.3)	28 (71.1)	8.7 (33)	550 (250)
AFF10	96.0 (243.8)	34.0 (86.3)	28.5 (72.4)	45.5 (115.5)	22.0 (55.8)	28 (71.1)	14.8 (56)	750 (341)
AFF12	101.0 (256.5)	44.0 (111.7)	27.5 (69.8)	47.5 (120.6)	26.0 (66.0)	28 (71.1)	25.5 (97)	1300 (591)
AFF16	112.0 (284)	52.0 (132.0)	32.0 (81.3)	50.0 (127.0)	30.0 (76.2)	28 (71.1)	56.2 (213)	1700 (773)

### Materials of Construction

**Body:** Carbon Steel  
**Paint:** Epoxy Enamel (Gray)  
**Internals:** Epoxy powder painted carbon steel  
**Seals:** Inorganic flange gasket (single element vessels)  
 Fluorocarbon o-ring (multi element vessels)  
**Internal Coating:** Epoxy enamel

### Specifications

**Max Pressure:** Up to 220-250 PSIG (15-17 barg)  
 (Consult Flow Chart)  
**Max Temperature:** 225°F (107°C)  
**Meets A.S.M.E. Code, Section VIII, Division 1 code stamped for rated pressure.**  
 Note: Consult factory for special requirements

Natural Gas  
Filters

## Application Notes

# GS Series Membrane Filters

## Balston GS Series Membrane Filters

The Balston GS Series Membrane Filter Cartridges combine absolute membrane filtration down to 0.01  $\mu\text{m}$ , with an integral pre-filter to protect the membrane.

Ideally suited for high purity compressed air and gas requirements, these membrane cartridges are available in several housing configurations shown above.

### Use as a Final Filter for:

- Ultra-high purity gases
- Corrosive or toxic gases
- Cylinder gases
- Doping gases



## Product Features

- Filtration to 0.01 micron
- No particle shedding
- Integral prefilter protects the membrane
- Corrosion resistant housings
- Pressure to 5,000 psig
- No particle shedding
- PTFE membrane with glass and fluorocarbon prefilter
- Chemically inert to most gases
- Easy to install

Specialty Gas Filtration



Analytical Gas Filtration

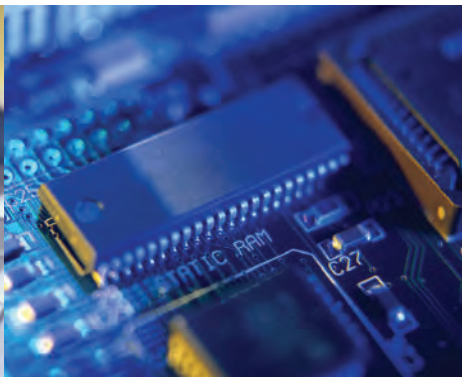

Process Gas Filtration



Critical Blow Off Applications

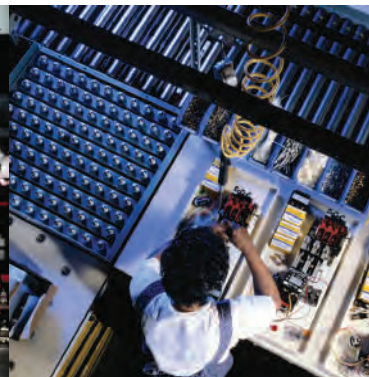

# 0.01 Micron Membrane Filters

## 0.01 µm Membrane Filters

The GS Membrane Cartridges represent state-of-the-art membrane filtration technology. An integral prefilter, bonded to a porous PTFE membrane, provides the user with extended membrane life, 0.01 µm filtration rating, and, most importantly, zero fiber shedding. The Balston GS Membrane filter also offers excellent chemical compatibility as a result of the inert materials of construction. All of these features combine to make the Balston GS cartridges the ideal choice for critical process gas filtration requirements.

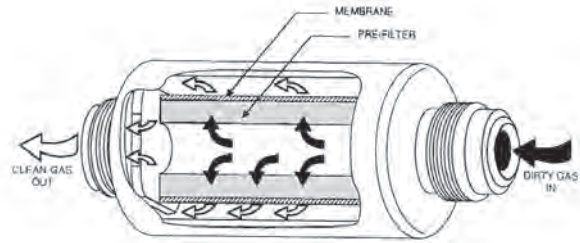

## Membrane Life Expectancy Comparison

Balston GS Membrane Cartridges, with their unique integral prefilter, offer up to 18 times the operating life of conventional membrane cartridges (as indicated in the life expectancy comparison below).

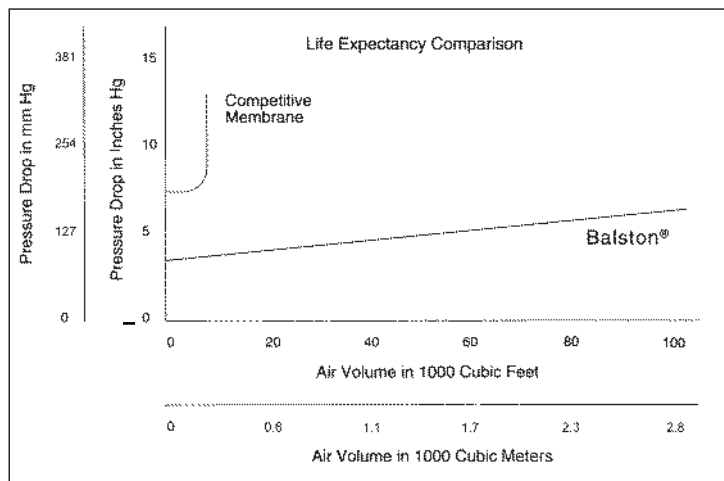

## Physical Properties, GS Membrane Cartridges

<b>Temperature Range</b>	-40°F to 250°F (-40°C to 121°C)
<b>Maximum pressure differential across membrane, Inside-to-outside flow:</b>	20 psi (size code 100 and 200) 60 psi (size code 050)
<b>Materials of Construction:</b>	Borosilicate glass with fluorocarbon resin binder prefilter and PTFE membrane
<b>Retention Efficiency:</b>	0.01 µm



# 0.01 Micron Membrane Filters

## Retention Efficiency Rating

The retention efficiencies of the Balston GS Series membrane cartridges were derived by John McCarthy, a staff research scientist at M.I.T. Dr. McCarthy used a submicron particle detection and sizing device to collect and analyze the filter efficiency data. The test procedure consisted of challenging the membrane filter with a sodium chloride aerosol solution which contained aerosol particles in a narrowly defined size range. Downstream from the filter, the effluent gas was evaluated for particulate contaminant size using a condensation nucleus counter.

There was no detectable penetration of 0.01  $\mu\text{m}$  particles through the membrane filters. Bulletin TI-834 details the efficiency rating procedure and experimental results of this study.



## Chemical Compatibility

**The GS Series Membrane Filter cartridges are compatible with the following gases (when installed in a stainless steel filter housing with PTFE seals).**

Ammonia	Chlorine (dry)	Hydrogen Bromide
Air (Compressed)	Diborane	Methylene Chloride
Argon	Dichlorosilane	Nitrogen
Arsine	Fluorine (dry)	Nitrous Oxide
Boron Trichloride	Freon	Phosphorous Oxychloride (dry)
Carbon Dioxide	Helium	Phosphine
Carbon Tetrafluoride	Hydrogen	Silane

# 0.01 Micron Membrane Filters

## Disposable Membrane Assemblies

### Disposable Filter Units (DFU's)

Consist of a membrane filter and an integral prefilter, permanently bonded into a plastic housing. DFU's have pressure ratings to 125 psig (8.6 barg), and may be installed using a variety of fitting systems.

#### 9933-05-95

Available in a transparent nylon housing, this DFU is an ideal choice for an economical membrane filter for use where its chemical compatibility is suitable.

#### 9922-11-95

This opaque PVDF DFU, with approximately double the membrane area of the 9933-05-95, is used where exceptional chemical compatibility is required.



Model 9933-05-95



Model 9922-11-95

### Principal Specifications

Model	9933-05-95	9922-11-95
Inlet and Outlet Ports	1/4" Tube	1/4" Tube
Materials of Construction		
Housing	Nylon	PVDF
Cartridge	PTFE (Glass	PTFE (Glass
Seals	None	None
Maximum Temperature	230°F(110°C)	250°F(121°C)
Maximum Pressure	125 psig (8.6 barg)	125 psig (8.6 barg)
Maximum Δ Pressure	60 psi (4 bar)	60 psi (4 bar)
Shipping Weight	0.1 lb (45 g)	0.2 lb (90 g)
Dimensions	3.25"H x 1.0"W (8cm x 2.5cm)	4.6"H x 1.43"W (12cm x 3.6cm)

### Ordering Information

For assistance, call toll-free at 1-800-343-4048

Filter Assembly (1) Complete with Membrane Filter Cartridge	Description
9933-05-95	In-line Nylon disposable filter with GS Membrane Cartridge
9922-11-95	In-Line disposable PVDF filter with GS Membrane Cartridge

#### Notes:

1 Disposable Filter Units are sold in boxes of 3 or 10. For example, a box of 3 DFU's in nylon housings, order: 3 (9933-05-95. For a box of 10, order: 9933-05-95.

# 0.01 Micron Membrane Filters

## Stainless Steel or PTFE Filter Housings - 1/8" to 1/2" Line Size

### 97S6

Miniature 316 stainless steel filter, with 1/4" NPT in-line ports, 5000 psig (345 barg) rating. The 97S6 has a replaceable membrane cartridge and is an economical alternative when a disposable product is not required.



Model 97S6



Model 91S6, 95S6, 95T  
(95S6 Shown)

### 91S6, 95S6, 95T

Miniature T-Type filters in 316 stainless steel. The 91S6 is rated for 650 psig (45 barg), the 95S6 is rated for 5000 psig (345 barg). The 95T is constructed of PTFE, and is rated at 150 psig (10 barg). The membrane cartridge is changed without breaking the inlet or outlet connections.

### 31S6, 33S6

Have 1/4" or 1/2" ports, 425 psig (29 barg) rating, can handle a higher gas flow rate, and have greater solids holding capacity than the Type 95 filters.



Model 31S6, 41S6  
(31S6 Shown)

### 41S6, 45S6

Are higher flow rate stainless steel filters with 1/4" or 1/2" NPT ports. The Type 45, with stainless steel bowl, has a 250 psig (17 barg) rating.



Model 33S6, 45S6  
(45S6 Shown)

Membrane  
Filters

# 0.01 Micron Membrane Filters

## Stainless Steel or PTFE Filter Housings - 1/8" to 1/2" Line Size

### Principal Specifications

Model	97S6	91S6	95S6	95T	31S6, 33S6	41S6, 45S6
Inlet and Outlet Ports	1/4" NPT	1/8" NPT (2)	1/8" NPT (2)	1/8" NPT (2)	1/2" NPT (2)	1/2" NPT (2)
Drain Port	None	1/8" NPT	1/8" NPT	1/8" NPT	1/4" , 1/8" NPT (6)	1/4" , 1/8" NPT (6)
Materials of Construction						
Head	316SS	316SS	316SS (4)	PTFE (4)	316SS	316SS
Bowl	316SS	316SS	316SS (4)	PTFE (4)	316SS	316SS
Internals	316SS	316SS	316SS (4)	PTFE (4)	316SS	316SS
Seals	Viton (5)	PTFE (3)	PTFE (3)	Viton (3,5)	Viton (5)	Viton (5)
Maximum Temperature	400°F(204°C)	400°F(204°C)	400°F(204°C)	300°F(149°C)	400°F(204°C)	400°F(204°C)
Maximum Pressure	5000 psig (345 barg) (1)	1500 psig (45 barg) (1)	5000 psig (345 barg) (1)	150 psig (10 barg) (1)	425 psig (29 barg) (1)	250 psi (17 barg) (1)
Shipping Weight	0.8 lbs (0.4 kg)	1.2 lbs. (0.5 kg)	1.3 lbs. (0.6 kg)	0.5 lbs. (0.2 kg)	5 lbs. (2.3 kg)	5.5 lbs. (2.5 kg)
Dimensions	1.25"D X 3.1"L (3.2cm X 7.9cm)	1.5"D X 3.7"L (3.8cm X 9.4cm)	1.8"D X 4"L (4.6cm X 10.2cm)	1.8"D X 4"L (4.6cm X 10.2cm)	2.25"D X 5.5"L (31S6) 2.6"D X 4.5"L (33S6) (5.7cm X 14cm) (31S6) (6.6cm X 11.4cm) (33S6)	2.25"D X 10"L (41S6) 2.6"D X 9"L (45S6) (5.7cm X 25.4cm)(41S6) (6.6cm X 22.9cm) (45S6)

### Ordering Information

For assistance, call toll-free at 1-800-343-4048 8AM to 6PM Eastern Time

Housing Only Model	Membrane Cartridge No. Required	Membrane Cartridges (Order Separately)	
		Box of 3	Box of 10
97S6	1	GS-3/050-05-95	GS-050-05-95
91S6	1	GS-3/050-11-95	GS-050-11-95
95S6	1	GS-3/050-11-95	GS-050-11-95
95T	1	GS-3/050-11-95	GS-050-11-95
31S6, 33S6	1	GS-3/100-12-95	GS-100-12-95
41S6, 45S6	1	GS-3/100-25-95	GS-100-25-95

#### Notes

1 Maximum pressure ratings are for temperatures to 200°F (93°C). Please consult factory for maximum pressure ratings at elevated temperatures.

2 Also available with 1/4" NPT ports, use designation Type 33S6-1/4 or 45S6-1/4.

3 PTFE encapsulated Viton seals are standard.

4 Constructed of materials which comply with NACE Specification MR-01-75. Request Certificate of Compliance.

5 PTFE encapsulated Viton and other seals are available upon request. Please consult factory.

6 Drain port for types 31S6 & 41S6 is 1/4".

# 0.01 Micron Membrane Filters

## High Pressure Membrane Filters - 1/2" Line Size

### 37/12, 37/25

316 stainless steel T-Type filters, 4000 psig rating. The Model 37 filters are also used when a larger line size or higher flow rate is required.

#### Principal Specifications

Model	37/12	37/25
Inlet and Outlet Ports	1/2" NPT (4)	1/2" NPT (4)
Drain Port	1/8" NPT	1/8" NPT
Materials of Construction		
Head	316SS (2)	316SS (2)
Bowl	316SS (2)	316SS (2)
Internals	316SS (2)	316SS (2)
Seals	Viton (3)	Viton (3)
Maximum Temperature	400°F(204°C)(1)	400°F(204°C)(1)
Maximum Pressure	4000 psig (276 barg)	4000 psig (276 barg)
Shipping Weight	6 lb (2.7 kg)	10 lb (4.5 kg)
Dimensions	2.75"Dia X 5.75"L (7cm X 14.6cm)	2.75"Dia X 10.25"L (7cm X 26cm)



Model 37/12, 37/25  
(37/25 Shown)

#### Ordering Information

For assistance, call toll-free at 1-800-343-404

Housing Only Model	Membrane Cartridges (Order Separately)
	Box of 10
37/12	GS-100-12-95
37/25	GS-100-25-95

#### Notes

1 Maximum pressure ratings are for temperatures to 200°F (93°C). Please consult factory for maximum pressure ratings at elevated temperatures.

2 Constructed of materials which comply with NACE Specification MR-01-75. Request Certificate of Compliance.

3 PTFE encapsulated Viton and other seals are available upon request. Please consult factory.

4 For 1" line sizes up to 800 psig (55 barg), consult factory.

# 0.01 Micron Membrane Filters

## Flow Rates

Filter Housing	Flow Rates, SCFM (Nm <sup>3</sup> /hr), at 2 psi (0.14 bar) Drop at Indicated Line Pressure (barg)													
	2 (0.1)	20 (1.4)	60 (4.1)	100 (6.9)	125 (8.6)	150 (10)	200 (14)	300 (21)	500 (34)	1000 (69)	2000 (138)	3000 (207)	4000 (276)	5000 (345)
9933-05-95	0.5 (0.8)	1.0 (1.7)	1.5 (2.5)	2.0 (3.4)	2.2 (3.7)	—	—	—	—	—	—	—	—	—
9922-11-95	0.5 (0.8)	1.0 (1.7)	1.7 (2.9)	2.2 (3.7)	2.3 (3.9)	—	—	—	—	—	—	—	—	—
91S6	0.5 (0.8)	1.0 (1.7)	1.8 (3.1)	2.5 (4.2)	2.8 (4.8)	3.0 (5.1)	3.4 (5.8)	4.1 (7.0)	5.3 (9.0)	—	—	—	—	—
95S6	0.5 (0.8)	1.0 (1.7)	1.8 (3.1)	2.5 (4.2)	2.8 (4.8)	3.0 (5.1)	3.4 (5.8)	4.1 (7.0)	5.3 (9.0)	7.4 (12.6)	10.5 (17.8)	12.9 (21.9)	14.8 (25.1)	16.5 (28.0)
95T	0.5 (0.8)	1.0 (1.7)	1.8 (3.1)	2.5 (4.2)	2.8 (4.8)	3.0 (5.1)	—	—	—	—	—	—	—	—
97S6	0.5 (0.8)	1.0 (1.7)	1.7 (2.9)	2.3 (3.9)	2.5 (4.2)	2.7 (4.6)	3.1 (5.3)	3.7 (6.3)	4.8 (8.2)	6.7 (11.4)	9.4 (16.0)	11.5 (19.5)	13.3 (22.6)	14.9 (25.3)
31S6, 33S6	1.0 (1.7)	2.1 (3.6)	4.6 (7.8)	7.0 (11.9)	7.7 (13.1)	8.4 (14.3)	9.6 (16.3)	11.6 (19.7)	—	—	—	—	—	—
37/12									14.8 (25.1)	20.8 (35.3)	29.3 (49.8)	35.9 (61.0)	41.4 (70.3)	—
41S6, 45S6	3.0 (5.1)	6.0 (10.2)	13.0 (22.1)	20.0 (34.0)	22.0 (37.4)	24.0 (40.8)	27.4 (46.6)	—	—	—	—	—	—	—
37/25								33.1 (56.2)	42.4 (72.0)	59.5 (101.1)	83.8 (142.4)	102.0 (173.3)	118.0 (200.5)	—

# Filters and Dryers for the Food Industry

## Balston Filters

### Steam Filters

Balston Steam Filters are in full compliance with the requirements of the US Food, Drug, and Cosmetic Act. These filters may be used with steam, air, and other gases which directly contact food and food ingredients, including milk, alcoholic, and non-alcoholic liquids.

### Sterile Air Filters

Balston Stainless Steel Compressed Air Filter Assemblies safeguard your operations from rust, pipscale, water, oil, and organisms usually found in compressed air. These filters will remove contaminants at a very high efficiency - up to 99.99% for 0.01 micron particles and droplets. Liquid releases from the filter cartridge to an automatic drain as rapidly as it enters the filter. This allows the filter to continue removing liquids for an unlimited time without loss of efficiency or flow capacity. The final stage of filtration removes all viable organisms with an efficiency rating of 99.9999+% at 0.01 micron. Select 1/4" to 1" line filters are constructed of 304 stainless steel and are designed to hold up to the harshest environments.



## Product Features

### Steam Filters

- Remove 98+% of 0.1 micron particles and remove liquid condensate at same efficiency
- Remove essentially all nonvolatile boiler feedwater chemicals
- Comply with USFDA, USDA, Health Protection Branch of Health and Welfare Canada, and 3-A accepted practices

### Sterile Air Filters

- All 304 stainless steel construction, ideal for standing up to aggressive washdown chemicals
- Remove 99.99% of 0.01 micron particles of oil, water, and dirt
- USDA (FSIS accepted for use in federally inspected meat and poultry plants)

Clean In Place (CIP) Filtration



Culinary Quality Steam



Sterile Air Filtration



# Filters for the Food Industry

## Steam Filters

Balston Series SR Filters are in full compliance with the requirements of the US Food, Drug and Cosmetic Act. They also meet the federal regulations for Indirect Food Additives for use as Basic Components of Repeated Use Food Contact Surfaces as specified in 21 CFR Part 177, and Current Good Manufacturing Practices, 21 CFR Part 110. These filters have been accepted by the USDA for use in federally inspected meat and poultry plants. Balston Steam Filters are in full compliance with the 3A Accepted Practices (Number 609-04) for producing steam of culinary quality. They are also in full compliance with the requirements of the Health Protection Branch of Health and Welfare Canada.

### Benefits

Balston Steam Filters eliminate particulate contamination of food products caused by direct contact with dirty steam. Other benefits include: reduction in steam condensate mixing with food products when steam is used for agitating, mixing, or cooking; eliminate taste and odor problems by reducing boiler feed-water carryover; Reduced maintenance requirements.

### How it Works

The steam filter contains a patented Microfibre® filter cartridge in a rugged stainless steel housing designed specifically for steam service.

As shown in the cutaway drawing, steam enters the housing into an expansion chamber, where much of the condensate is knocked out of the steam as a result of the abrupt change in flow direction and velocity. The steam then flows upward in the housing, through the Balston grade SR microfibre filter cartridge (outside-to-inside flow), and then downward to the exit port. The grade SR filter cartridge, rated at 98+% efficiency for 0.1 micron and larger particles, removes essentially all the suspended solid particles and the remaining water droplets. The water draining from the filter cartridge and the expansion chamber is automatically removed from the housing by the automatic condensate drain.

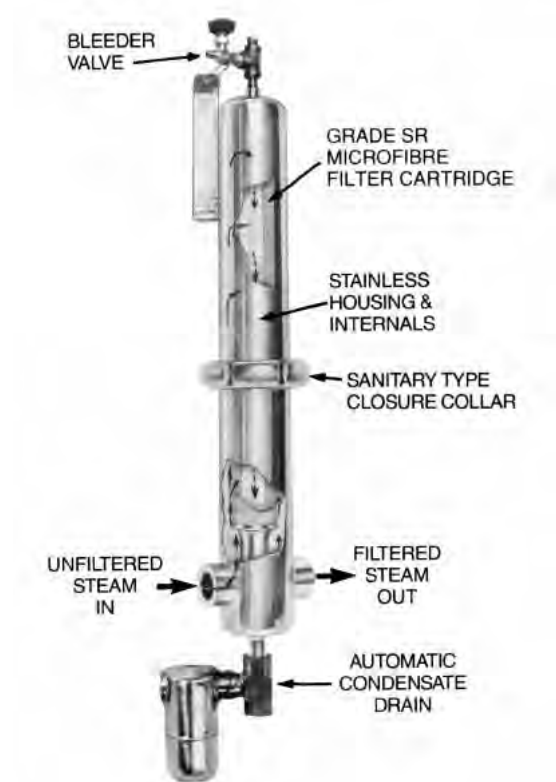

Model 23/75SR



Model SP6-23/75SR



# Filters for the Food Industry

## Steam Filters

### Recommended Steam Filters

For 3/4" and 1" Steam Lines	For 1-1/2" Steam Lines	For 2" Steam Lines
Model 23/75SR is recommended in smaller lines with a steam flow of up to 500 lbs. per hour. The filter is complete with filter cartridge, steam trap, and bleeder valve.	Model SP3-23/75SR is recommended. It will filter up to 1500 lbs. of steam per hour. Each of the three filters has its own steam trap. A master trap disposes of most condensate before it reaches the filters. Manifolds can be connected to flow from left to right or right to left.	Model SP4-23/75SR is recommended. It will filter up to 2000 lbs. of steam per hour. The Model SP6-23/75SR will filter up to 3000 lbs of steam per hour. Steam trap and manifold features are the same as the Model SP3-23/75.

### Principal Specifications

Model	23/75SR	SP2-23/75SR	SP3-23/75SR	SP4-23/75SR	SP6-23/75SR
Port Size	1" NPT	1 1/2" NPT	1 1/2" NPT	2" NPT	2" NPT
Max Pressure	125 psig (3.6 barg)	125 psig (3.6 barg)	125 psig (3.6 barg)	125 psig (3.6 barg)	125 psig (3.6 barg)
Flow Rate	500 lbs/hr (230 kg/hr)	1000 lbs/hr (450 kg/hr)	1500 lbs/hr (680 kg/hr)	2000 lbs/hr (910 kg/hr)	3000 lbs/hr (1360 kg/hr)
Materials of Construction	304 SS	304 SS	304 SS	304 SS	304 SS
Seals	EPR (2)	EPR (2)	EPR (2)	EPR (2)	EPR (2)
Shipping Wt	26 lbs. (12 kg)	Approx. 110 lbs (50 kg)	190 lbs. (86 kg)	220 lbs. (100 kg)	280 lbs. (127 kg)
Dimensions	7"W X 35"L (18cm X 88cm)	22"W X 46"L X 11"D (56cm X 117cm X 28cm)	29"W X 48"L X 21"D (74cm X 122cm X 53cm)	36"W X 48"L X 21"D (91cm X 122cm X 53cm)	50"W X 47.8"L X 22"D (74cm X 122cm X 53cm)

### Ordering Information

For assistance, call toll-free at 1-800-343-4048 8AM to 5PM Eastern Time

Model	23/75SR	SP2-23/75SR	SP3-23/75SR	SP4-23/75SR	SP6-23/75SR
Replacement Filter Cartridges (Box of 10)	200-75-SR (3)	200-75-SR (3)	200-75-SR (3)	200-75-SR (3)	200-75-SR (3)
Filter Cartridges per housing	1	2	3	4	6

#### Notes:

- 1 Each SP3, SP4, SP6 filter is supplied mounted on a stand.
- 2 Constructed of food grade EPR.
- 3 Each Steam Filter Assembly is supplied with filter cartridges installed.

# Filters for the Food Industry

## Stainless Steel Harsh Environment Filters for Food Processing and Packaging

All 304 stainless steel construction, ideal standing up to aggressive washdown chemicals

Remove 99.99% of 0.01 micron particles of oil, water, and dirt from compressed air and other gases

For Sterile Air Requirements:

Remove all viable organisms

USDA/FSIS accepted for use in federally inspected meat and poultry plants

Low pressure drop

Continuously trap and drain liquids

Remove trace oil vapor with adsorbent cartridges



Models 6006 and 6008

### Balston® Stainless Steel Compressed Air Filter Assemblies

Protect your equipment and delicate instruments from the dirt, water, and oil usually found in compressed air and other gases. These filters will remove contaminants at a very high efficiency - up to 99.99% for 0.01 micron particles and droplets. Liquid releases from the filter cartridge to an automatic drain as rapidly as it enters the filter. This allows the filter to continue removing liquids for an unlimited time without loss of efficiency for flow capacity. Select 1/4" to 1" line filters are constructed of 304 stainless steel and are designed to hold up to the harshest environments.

# Filters for the Food Industry

## Stainless Steel Harsh Environment Filters for Food Processing and Packaging

### Filter Cartridge Description

General purpose applications such as plant compressed air	Single stage filtration. Use a Grade DX filter cartridge
Instrument air and other critical air requirements	Two stage filtration is necessary. Use a Grade DX followed by a Grade BX filter cartridge. As a general rule, a Grade BX filter cartridge should not be used alone.
Removal of trace compressor oil vapor	For rare instances where even a trace amount of oil vapor can cause a problem, three stage filtration is necessary. Use a Grade DX followed by a Grade BX, and a type CI cartridge.

### Physical Properties, Microfibre Filter Cartridges

Temperature Range	-150°F to 300°F (-100°C - 149°C)
Maximum Pressure Differential Across Filter, Inside-to-Outside Flow:	100 psi (7 barg)
Materials of Construction	Borosilicate glass microfibers with fluorocarbon resin binder. Resistant to water, all hydrocarbon and synthetic lubricants.

### Retention Efficiency

Grade	Efficiency for 0.01 Micron Particles and Droplets
DX	93%
BX	99.99%

### Balston Filter Cartridges

Parker provides two grades of coalescing filter cartridges, Grade DX and Grade BX. Singly or in tandem, these filters satisfy all requirements for removing liquid and solid contaminants from compressed air. Parker also has an activated carbon adsorbent CI-type cartridge for the removal of trace oil vapors from a compressed air line. The activated carbon cartridge is Grade 000.

### How to Select the Filter Cartridge and Housing

- 1 Decide which grade(s) of filter cartridges fits the application (see selection boxes at left).
- 2 Select the filter housing with a port size equal to the line size where the filter is to be located.
- 3 For a new installation in which the line size has yet to be selected, determine the gas flow rate and pressure at the point where the filter will be located, and then refer to the flow chart on the reverse side of this data sheet. NOTE: The filter port size must be equal to or larger than the line size (when specified).

### How to Order the Filter Assembly

- 1 Build your own custom filter assembly using the guideline matrix on Page 170 and specify your model number. Example: 1/2" filter with DPI and Auto Drain with Grade DX Filter = 6004N-01A-DX.
- 2 Each assembly is shipped with the filter cartridge installed. To order additional filter cartridges, indicate the model number of the cartridges, and the grade. Examples 050-05-DX, 050-05-BX. The grade used for Type CI cartridges is 000 (CI-100-12-000).

Note: Assemblies with CI Cartridges are shipped with the adsorbent cartridge wrapped separately. This shipping method prolongs the life of the cartridge.

# Filters for the Food Industry

## Stainless Steel Harsh Environment Filters

### 1/4" to 1" Line Size

#### Models 6102, 6002, 6904

The 6002 series models are 1/4" line size filters designed for lower flow systems and installations with space limitations. Models 6102 and 6002 are offered with two drain options: a manual drain or an auto float drain, for maintenance-free operation. Model 6904 offers 1/2" inlet and outlet connections for applications requiring 1/2" pipe with space limitations.



Models 6102, 6002, 6904

Model 6004

#### Model 6004

The 6004 series models are 1/2" line size filters designed for moderate flow rate systems. This series has increased liquid holding capacity, which safeguards sensitive end use points from system upsets and morning start ups.

#### Models 6006 and 6008

The 6006 and 6008 series models are 3/4" and 1" line size filters respectively. These are designed for high flow rate systems servicing multiple end use points. These are also offered with a high capacity auto float drain option.



Models 6006 and 6008

### How to Order the Filter Assembly\*

Build your own custom filter assembly using the guideline matrix below and specify your model number. Example: 1/2" filter with Auto Drain and Grade DX Filter = 6004N-0A1-DX.

\*Consult Factory. Not all configurations are available.

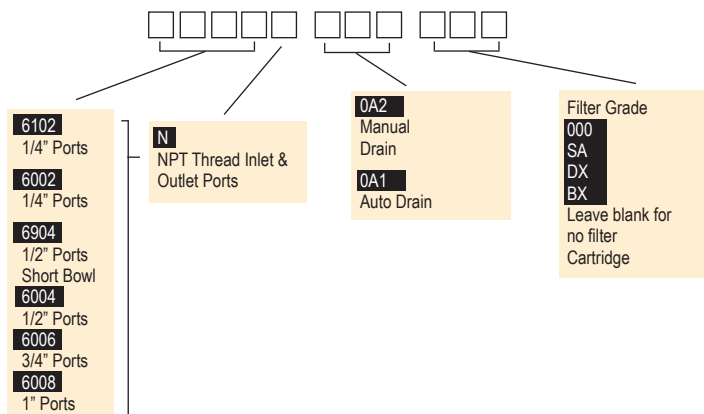

Filters for the Food Industry

# Filters for the Food Industry

## Stainless Steel Harsh Environment Filters

### 1/4" to 1" Line Size

#### Flow Rates

Filter Housing Model	Port Size	Filter Cartridge Grade	Flow rates SCFM (Nm <sup>3</sup> /hr), at 2 psi (0.14 bar) (1) drop at indicated line pressure. Refer to Principal Specification Charts in each product data sheet for maximum pressure rating of each housing								
			2 (0.1)	20 (1.4)	40 (2.8)	80 (5.5)	100 (6.9)	125 (8.6)	150 (10)	200 (14)	250 (17)
6102N	1/4"	DX	13.5 (23)	8 (14)	11 (19)	20 (34)	25 (42)	30 (51)	36 (61)	---	---
		BX	1 (2)	2 (3)	3.5 (6)	5.7 (10)	6.8 (12)	8 (14)	10 (17)	---	---
6002N	1/4"	DX	9 (15)	19 (32)	39 (66)	51 (87)	63 (107)	76 (129)	90 (153)	117 (199)	145 (246)
6904N	1/2"	BX	3 (5)	8 (14)	11 (19)	21 (36)	25 (42)	31 (53)	36 (61)	47 (80)	58 (99)
		CI	2 (3)	5 (8)	7 (12)	12 (20)	15 (25)	18 (31)	22 (37)	28 (48)	35 (59)
		SA	---	8 (14)	11 (19)	21 (36)	25 (42)	31 (53)	36 (61)	---	---
6004N	1/2"	DX	19 (32)	41 (70)	65 (110)	113 (192)	137 (233)	166 (282)	196 (333)	257 (473)	316 (537)
		BX	9 (15)	19 (32)	30 (51)	51 (87)	63 (107)	76 (129)	90 (153)	117 (199)	145 (246)
		CI	6 (10)	12 (20)	19 (32)	32 (54)	39 (66)	48 (82)	56 (95)	73 (124)	90 (153)
		SA	---	19 (32)	30 (51)	51 (87)	63 (107)	76 (129)	90 (153)	---	---
6006N	3/4"	DX	37 (63)	78 (133)	123 (209)	214 (364)	259 (440)	315 (535)	371 (630)	484 (822)	596 (1013)
		BX	10 (17)	21 (36)	34 (58)	56 (95)	70 (119)	85 (144)	101 (172)	131 (223)	162 (275)
		CI	8 (14)	16 (27)	26 (44)	44 (75)	53 (90)	65 (110)	76 (129)	99 (168)	122 (207)
		SA	---	21 (36)	34 (58)	56 (95)	70 (119)	85 (144)	101 (172)	---	---
6008N	1"	DX	55 (93)	115 (195)	181 (308)	314 (533)	380 (646)	463 (787)	546 (928)	711 (1208)	877 (1490)
		BX	11 (19)	23 (39)	37 (63)	64 (109)	77 (131)	94 (160)	111 (189)	144 (245)	178 (302)
		CI	10 (17)	20 (34)	32 (54)	56 (95)	67 (114)	82 (139)	96 (163)	125 (212)	154 (262)
		SA	---	23 (39)	37 (63)	64 (109)	77 (131)	94 (160)	111 (189)	---	---

Notes:

1 The SA filter grade produces a 3 psi at maximum rated flow differential pressure drop.

#### Sterile Air Filters

Balston grade SA filter cartridges, rated at 99.9999+% efficiency for 0.01 micron particles, is at least 30 times better than the accepted standard for sterile air filters developed by independent research organizations in the U.S. and U.K. (request bulletin TI-105A for a detailed discussion on Balston filter efficiency rating procedure, and Bulletin TI-935 for an independent test report on balstonSterile Air Filters). Balston Sterile Air Filters are in full compliance with the requirements of the FDA.

#### Steam Sterilization Procedure

In installations where the sterile air filter requires steam sterilization, we recommend the following procedures:

The steam sterilization pressure should not exceed 60 psig (4 barg). Preferably, it should be held to 40 psig (3 barg) or less. A typical sterilization cycle is 30 psig (2 barg) steam for 30 minutes. Steaming time can be increased as desired without harm to the filter cartridges. The steam flow should not exceed the normal air flow for the unit. To ensure no buildup of condensate in the housing, condensate should be drained from the filter by a condensate drain valve during the steaming process. The cleanliness of the steam is an important factor influencing the life of the Sterile Air Filter cartridges. Parker strongly recommends using Model 23 Steam Filters to ensure optimum operating life. When autoclaving, the Grade SA filter cartridges will tolerate temperatures to 300°F (149°C) in dry gas. Viton or other heat resistant seals should be used in the housing.

Filters for the Food Industry

# Filters for the Food Industry

## Stainless Steel Harsh Environment Filters

### Principal Specifications

Model	6102	6002	6904	6004	6006	6008
Port Size	1/4" NPT	1/4" NPT	1/2" NPT	1/2" NPT	3/4" NPT	1" NPT
Materials of Construction						
Head	316 Stainless Steel	304 Stainless Steel				
Bowl	316 Stainless Steel	304 Stainless Steel				
Internals	Acetal	Stainless Steel				
Seals	Viton	Buna-N Food Grade				
Maximum Temperature	140°F (60°C) (1)	120°F (49°C) (1)				
Maximum Pressure	150 psig (10 barg) (2)	175 psig (12 barg) (2)				
Minimum Pressure	15 psig (1 barg) (3)	15 psig (1 barg) (3)				
Shipping Weight	3.5 lbs. (1.6 kg)	3.5 lbs. (1.6 kg)	3.5 lbs. (1.6 kg)	4.0 lbs. (18 kg)	11 lbs. (5 kg)	12 lbs. (5.5 kg)
Dimensions	1.5"W x 4.2"L (3.8cm x 11.7cm)	3"W X 7"L (7cm X 18cm)	3"W X 7"L (7cm X 18cm)	3"W X 10"L (7cm X 25cm)	4"W X 10"L (10cm X 25cm)	4"W X 12"L (10cm X 30cm)

#### Notes:

1 Max. temperature with auto drain. Max. temperature with manual drain is 275°F (135°C).

2 Max. pressure with auto drain. Max. pressure with manual drain is 250 psi (17 barg).

3 Required for proper operation of auto drain.

### Ordering Information For assistance, call toll-free at 1-800-343-4048 8AM to 5PM Eastern Time

#### Assembly Ordering Information

Model P/N	Filter Tube	Drain (Manual)	Drain (Auto. Float)	Mounting Bracket (stainless steel)
6102N-0A0-(?X)	070-063-(?X)	SAP05481	N/A	N/A
6102N-0A1-(?X)	070-063-(?X)	N/A	C02-2392	N/A
6002N-0A2-(?X)	100-12-(?X)	C01-0108	N/A	C01-0094
6002N-0A1-(?X)	100-12-(?X)	N/A	C01-0109	C01-0094
6002N-0A2-SA	100-12-SA	C01-0108	N/A	C01-0094
6002N-0A2-000	CI-100-12-000	C01-0108	N/A	C01-0094
6904N-0A2-(?X)	100-12-(?X)	C01-0108	N/A	C01-0094
6904N-0A1-(?X)	100-12-(?X)	N/A	C01-0109	C01-0094
6904N-0A2-SA	100-12-SA	C01-0108	N/A	C01-0094
6904N-0A2-000	CI-100-12-000	C01-0108	N/A	C01-0094
6004N-0A2-(?X)	100-18-(?X)	C01-0108	N/A	C01-0094
6004N-0A1-(?X)	100-18-(?X)	N/A	C01-0109	C01-0094
6004N-0A2-SA	100-18-SA	C01-0108	N/A	C01-0094
6004N-0A2-000	CI-100-18-000	C01-0108	N/A	C01-0094
6006N-0A2-(?X)	200-176-(?X)	C01-0108	N/A	C01-0094
6006N-0A1-(?X)	200-176-(?X)	N/A	C01-0109	C01-0094
6006N-0A2-SA	200-176-SA	C01-0108	N/A	C01-0094
6006N-0A2-000	200-176-000	C01-0108	N/A	C01-0094
6008N-0A2-(?X)	200-185-(?X)	C01-0108	N/A	C01-0094
6008N-0A1-(?X)	200-185-(?X)	N/A	C01-0109	C01-0094
6008N-0A2-SA	200-185-SA	C01-0108	N/A	C01-0094
6008N-0A2-000	CI-200-185-000	C01-0108	N/A	C01-0094

#### Replacement Filter Cartridge Ordering Information

Model P/N	6102	6002/6904	6004	6006	6008
Replacement Filter Cartridges					
Number required	1	1	1	1	1
Box of 5	5/070-063-(?X)	5/100-12-(?X)	5/100-18-(?X)	5/200-176-(?X)	5/200-185-(?X)
Box of 10	070-063-(?X)	100-12-(?X)	100-18-(?X)	200-176-(?X)	200-185-(?X)
Box of 10	070-063-SA	100-12-SA	100-18-SA	200-176-SA	200-185-SA
CI Cartridges (box of 1)	---	CI-100-12-000	CI-100-18-000	CI-200-176-000	CI-200-185-000

# Filters for the Food Industry

## Balston 2 Stage Compressed Air Filter Systems

Full-featured with differential pressure indicators, auto drains, sight glasses, pressure relief valve, and bayonet bowl-to-head connection

Lifetime (20 year) warranty

Continuously trap and drain liquids

Remove 99.99% of 0.01 micron particles of oil, water, and dirt from compressed air and other gases

Low pressure drop



### Applications:

These filters are ideal for safeguarding critical production equipment from corrosive compressor condensate that can cause catastrophic failures and unexpected downtime. Ideal applications are:

- **Instrumentation**
- **Air actuators and air cylinders**
- **Pneumatic packaging machines**
- **Pneumatic conveyors**
- **Air operated production equipment**
- **Air operated lifts**

The Parker Balston 2 stage filter systems offer the best protection to all your pneumatic equipment and instrumentation. These high efficiency filtration systems will eliminate costly maintenance and unexpected downtime due to contaminated compressed air.

Safeguard your operations from rust, pipescale, water, and oil. The prefilters will remove contaminants at a very high efficiency - up to 93% for 0.01 micron particles and droplets. Liquid releases from the filter cartridge to an automatic drain as rapidly as it enters the filter. This allows the filter to continue removing liquids for an unlimited time without loss of efficiency or flow capacity.

The final stage of filtration removes all remaining contaminants with an efficiency rating of 99.99+% at 0.01 microns. Select 1/4" to 1 1/2" line filters are constructed of aluminum with a durable powder coating designed to hold up to the dirtiest compressed air systems.

Filters for the  
Food Industry

# Filters for the Food Industry

## Balston 2000 Series

The Balston filter performance complies with several of the international standards as written in ISO8573-1 which is fast becoming the industry standard method for specifying compressed air purity. The following diagrams illustrate the various classes of purity that can be achieved by using the Balston grade DX filter media or BX media or a combination of both.

### Explanation for 2 Stage Compressed Air Filter System

**1st Stage: Grade DX** Removal of large quantities of oil, water, and dirt from compressed air. Prefilter to Grade BX

**2nd Stage: Grade BX** Complete removal of trace quantities of oil, water, and dirt down to 0.01 microns.

Class	Solid		Water		Oil	
	Maximum Particle Size (micron)	Maximum Concentration ppm (mg/m <sup>3</sup> )	Maximum Pressure Dewpoint °F	Maximum Pressure Dewpoint (°C)	Maximum Concentration ppm	Maximum Concentration (mg/m <sup>3</sup> )
1	0.1	.08 (0.1)	-94	(-70)	.008	(0.01)
2	1	.8 (1)	-40	(-40)	.08	(0.1)
3	5	4.2 (5)	-4	(-20)	.83	(1)
4	15	6.7 (8)	37	(+3)	4.2	(5)
5	40	8.3 (10)	45	(+7)	21	(25)
6	-	-	50	(+10)	-	-

### ISO Class Example **1** Solid **4** Water **1** Oil

#### ISO Class **1 4 1**

Any compressor with aftercooler, 2-stage coalescing and refrigerated dryer for use with instrument quality air.

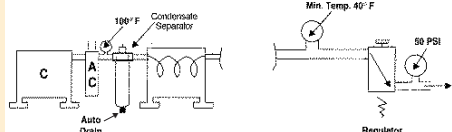

ADDITIONAL SPECS: CGA - G7.1 (Grade D & E) ISA S7.3, sFed. Std. 209 (Class 100)

#### ISO Class **1 1 1**

Any compressor with aftercooler and 2-stage coalescing. Air intended for use as lubricated control valves, cylinders and parts blow-down.

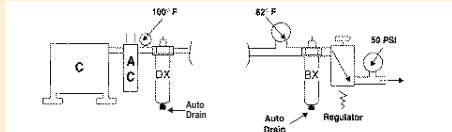

ADDITIONAL SPECS: Mil. Std. 282 H.E.P.A., U.S.P.H.S. 3A accepted particles for milk.

#### ISO Class **2 2**

Any compressor with aftercooler and coalescer. Air intended for use with lubricated air tools, air motors, cylinders, shot blasting, non-frictional valves.

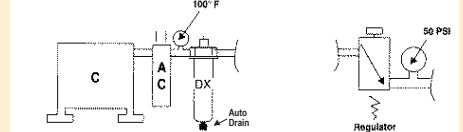

ADDITIONAL SPECS: CGA - G7.1 (Grades A & Ba1)

## Flow Rates

Filter Housing Model	Port Size	Filter Cartridge Grade	Flow rates SCFM (Nm <sup>3</sup> /hr), at 4 psi (0.27 bar) drop at indicated line pressure. Refer to Principal Specification Charts in each product data sheet for maximum pressure rating of each housing PSIG								
			2 (0.1)	20 (1.4)	40 (2.8)	80 (5.5)	100 (6.9)	125 (8.6)	150 (10)	200 (14)	250 (17)
2A-2002N-3B1	1/4"	DX	9 (15)	19 (32)	39 (66)	51 (87)	63 (107)	76 (129)	90 (153)	117 (199)	145 (246)
2A-2003N-3B1	3/8"	BX	3 (5)	8 (14)	11 (19)	21 (36)	25 (42)	31 (53)	36 (61)	47 (80)	58 (99)
2A-2004N-3B1											
2A-2104N-3B1	1/2"	DX	19 (32)	41 (70)	65 (110)	113 (192)	137 (233)	166 (282)	196 (333)	257 (437)	316 (537)
		BX	9 (15)	19 (32)	30 (51)	51 (87)	63 (107)	76 (129)	90 (153)	117 (199)	145 (246)
2A-2206N-3B1	3/4"	DX	37 (63)	78 (133)	123 (209)	214 (364)	259 (440)	315 (535)	371 (630)	484 (822)	596 (1013)
		BX	10 (17)	21 (36)	34 (58)	56 (95)	70 (119)	85 (144)	101 (172)	131 (223)	162 (275)
2A-2208N-3B1	1"	DX	55 (93)	115 (195)	181 (308)	314 (533)	380 (646)	463 (787)	546 (928)	711 (1208)	877 (1490)
		BX	11 (19)	23 (39)	37 (63)	64 (109)	77 (131)	94 (160)	111 (189)	144 (245)	178 (302)
2A-2312N-3B1	1 1/2"	DX	98 (167)	203 (345)	319 (542)	554 (941)	670 (1138)	816 (1386)	963 (1636)	1254 (2131)	1546 (2627)
		BX	22 (37)	46 (78)	74 (126)	129 (219)	155 (263)	189 (321)	223 (379)	290 (493)	358 (608)



# Filters for the Food Industry

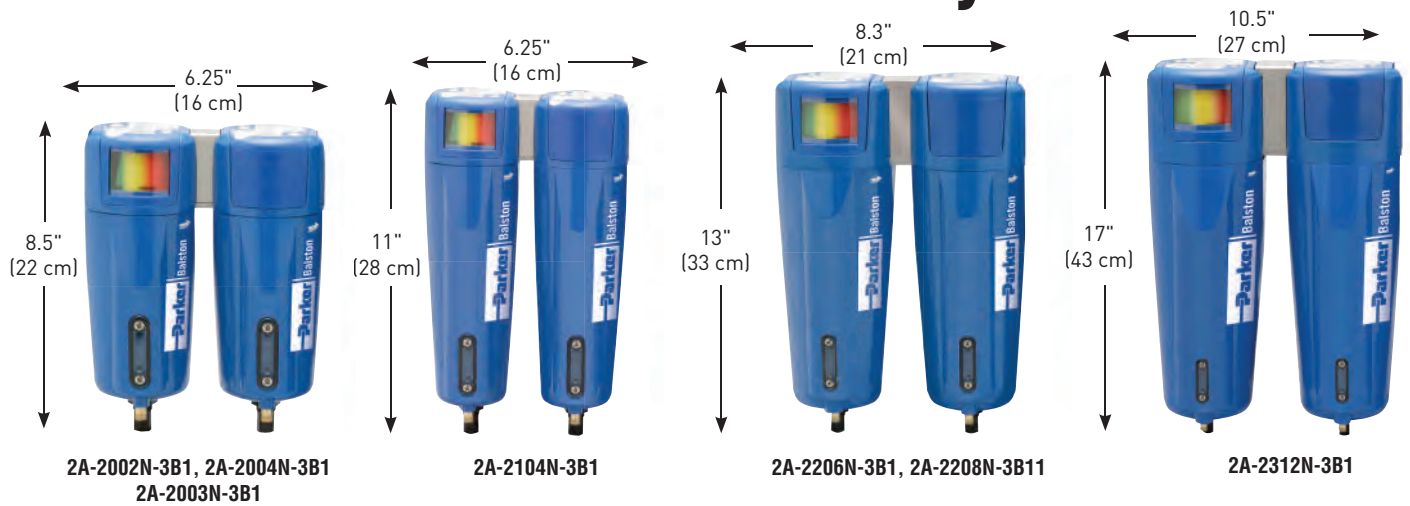

## Principal Specifications

Model	2A-2002, 2003, 2004	2A-2104	2A-2206	2A-2208	2A-2312
Port Size	1/4" NPT	1/2" NPT	3/4" NPT	1" NPT	1.5" NPT
Materials of Construction					
Head	Aluminum	Aluminum	Aluminum	Aluminum	Aluminum
Bowl	Aluminum	Aluminum	Aluminum	Aluminum	Aluminum
Internals	Aluminum	Aluminum	Aluminum	Aluminum	Aluminum
Seals	Buna-N Food Grade	Buna-N Food Grade	Buna-N Food Grade	Buna-N Food Grade	Buna-N Food Grade
Maximum Temperature (1)	130°F (54°C)	130°F (54°C)	130°F (54°C)	130°F (54°C)	130°F (54°C)
Maximum Pressure (2)	175 psig (12 barg)	175 psig (12 barg)	175 psig (12 barg)	175 psig (12 barg)	175 psig (12 barg)
Minimum Pressure (3)	15 psig (1 barg)	15 psig (1 barg)	15 psig (1 barg)	15 psig (1 barg)	15 psig (1 barg)
Shipping Weight	4.2 lbs. (1.9 kg)	5 lbs. (2.3 kg)	11.7 lbs. (5.3 kg)	11.7 lbs. (5.3 kg)	27 lbs. (12 kg)
Dimensions	6.25"W X 8.5"L	6.25"W X 11"L	8.3"W X 13"L	8.3"W X 13"L	10.5"W X 17"L

### Notes:

1 Max. temperature with auto drain

2 Max. pressure with auto drain. Max. pressure with manual drain is 250 psi (17 barg).

3 Required for proper operation of auto drain.

## Ordering Information For assistance, call toll-free at 1-800-343-4048 8AM to 5PM Eastern Time

Assembly Ordering Information		Replacement Cartridge	
Model	P/N	Box of 5	Box of 10
2A-2002N-3B1	1/4" 2-Stage (DX, BX) Filter Assembly	5/100-12-DX	100-12-DX
2A-2003N-3B1	3/8" 2-Stage (DX, BX) Filter Assembly	5/100-12-BX	100-12-BX
2A-2004N-3B1	1/2" 2-Stage (DX, BX) Filter Assembly		
2A-2104N-3B1	1/2" 2-Stage (DX, BX) Filter Assembly	5/100-18-DX	100-18-DX
		5/100-18-BX	100-18-BX
2A-2206N-3B1	3/4" 2-Stage (DX, BX) Filter Assembly	5/150-19-DX	150-19-DX
		5/150-19-BX	150-19-BX
		5/150-19-SA	
2A-2208N-3B1	1" 2-Stage (DX, BX) Stainless Assembly	5/150-19-DX	150-19-DX
		5/150-19-BX	150-19-BX
		5/150-19-SA	
2A-2312N-3B1	1" 2-Stage (DX, BX) Stainless Assembly	5/200-35-DX	200-35-DX
		5/200-35-BX	200-35-BX

4 2 each of mounting brackets are required for adequate support.

5 For CRN rated assemblies add a "C" to the Model Number. Example: 2A-C2104N-3B1

Filters for the  
Food Industry

# Filters for the Food Industry

## CAMTU Compressed Air Microbial Test Unit

### Identify Sources of Contamination in Compressed Air and Improve Food Safety

Compressed air is used in a broad range of applications in the food processing industry, such as mixing of ingredients, cutting, sparging, drying of product, transporting/propelling product through processing systems and packaging of final product. In many of these applications, compressed air is in direct contact or indirect contact with food product. The impurities in the compressed air may contaminate the food product which can result in change of color and taste, reduced shelf life, in addition to exposure to bacteria and other micro-organisms, can result in product recalls.

Compressed air is warm, dark and contains moisture which is the ideal environment to promote the production of microbes. These microbes migrate through the entire compressed air system and are released at exit points, critical areas that food, packaging or surface areas come in direct contact.

Recently, Safe Quality Foods (SQF) released a 7th edition amendment in sections 10.5.7 and 11.7.5 stating, compressed air used in the manufacturing process shall be clean and present no risk to food safety. Others have also identified compressed air as a source of contamination and risk to food safety.



### Product Features:

- **Lightweight and ergonomically designed for ease of use**
- **Constructed of durable polypropylene - easily sanitized**
- **Pre-filled petri dishes with specialized tryptic soy agar designed to hold up to compressed air flow/pressure**
- **No electrical supply required**
- **No refrigeration required for the petri dishes – 300 day shelf life**
- **Quick sampling time – 20 seconds**
- **Complete kit with connection tubing, pressure regulator/metering orifice, shut off valve, timer and petri dishes**

# Filters for the Food Industry

## CAMTU Compressed Air Microbial Test Unit

British Compressed Air Society has produced a specification for dewpoint (-40F/C), oil removal <0.01mg/m<sup>3</sup> and particulate removal (including micro-biological particles) 0.1-0.5 microns. Request white paper by Lee Scott, "Reducing Contamination Risks of Compressed Air in Food Plants".

However, to date, the only devices capable of sampling compressed air systems for microbes are expensive, very cumbersome, require lengthy sampling times and require extensive training. Parker Balston recognized the need for an alternative device that is easily transported throughout the food plant and can provide a quick qualitative analysis of compressed air purity requiring very little training.

The Parker Balston CAMTU (compressed air microbial test unit) is easily transported weighing less than a pound. It comes complete with connection tubing, shut off valve and a special designed pressure regulator and metering orifice. These matched components provide the exact amount of compressed air exposure for each sampling. The petri dishes are filled with specialized tryptic soy agar designed to hold up to compressed air flow and pressure. TSA is used for the cultivation of a wide variety of microorganisms including most bacteria and mold spores.

The Parker Balston CAMTU has been validated by Dr. Mclandsborough, head of the Food Science Department of the University of Massachusetts, Amherst MA. —request white paper, "Comparison of the Compressed Air Microbial Testing Unit (CAMTU) to a standard method of bioaerosol sampling."

To obtain a sample, simply plug the connection tubing into the sample point on the compressed air system, insert a petri dish into the CAMTU, close the CAMTU, open the shutoff valve and expose the agar for 20 seconds. After exposure simply place the petri dish in an incubator for 48 hours or in a controlled environment of at least 68°F and observe for colony forming units (CFUs).

This is an ideal device to incorporate into your Good Manufacturing Practices program for monitoring all the identified HACCP risk points. For those risk points where microbes are discovered, we would recommend installing Balston 3 stage sterile air systems which will remove oil, water, rust, pipescale and all microbes from the compressed air (Request literature bulletin FMB09). The CAMTU can then be used to monitor those filter systems for optimum performance.



# Filters for the Food Industry

## CAMTU Compressed Air Microbial Test Unit



CAMTU Sampling System



Filters for the  
Food Industry

# Filters for the Food Industry

## CAMTU Compressed Air Microbial Test Unit



Storage and Carrying Case

### Principal Specifications and Ordering Information

#### Complete Kit: C01-0128

CAMTU Sampling Device	C01-0122
DFU Assembly	CO2-2418
Timer device	CO1-0123
Tubing ¼" OD	A01-0459
Regulator/Metering Assembly	CO1-0125
Sanitizing spray bottle	CO1-0124
Shut off valve	CO1-0126
Petri dishes (20 each)	CO1-0127
Dimensions	15.63"w x 13.63"h x 6.38"d (40cm x 35cm x 16cm)
Shipping Weight	7 lbs. (3.2 kg)

# Filters for the Food Industry

## Balston 3 Stage Sterile Air Filter Systems

Safeguard your operations from rust, pipscale, water, oil, and organisms. The prefilters will remove contaminants at a very high efficiency - up to 99.99% for 0.01 micron particles and droplets. Liquid releases from the filter cartridge to an automatic drain as rapidly as it enters the filter. This allows the filter to continue removing liquids for an unlimited time without loss of efficiency or flow capacity.

The final stage of filtration removes all viable organisms with an efficiency rating of 99.9999+% at 0.01 microns. Select 1/4" to 1 1/2" aluminum with a durable powder coating designed to hold up to the dirtiest compressed air systems.



### Product Features:

- Remove all viable organisms - at 99.9999+% @0.01 microns
- Remove 99.99% of 0.01 micron particles of oil, water, and dirt from compressed air and other gases
- Low pressure drop
- Continuously trap and drain liquids

### The Application:

Compressed air is contaminated with compressor oil, water condensate, pipe scale and rust all of which provide the ideal environment and means to grow bacteria. This natural occurring contaminate can also effect the taste, appearance and shelf life of food product. The food processing and packaging industry utilizes compressed air extensively throughout their facilities. Compressed air is used to push and propel product, cut and

mix product in addition to packaging product.

Cahoon Farms in Walcott, New York uses Parker Balston three stage filtration systems for all their compressed air and sterile air applications. Cahoon Farms packages fresh sliced apples and cherries, dried apples, and other assorted dried fruits. Compressed air is used extensively throughout the facility servicing pneumatic equipment, slicing and mixing food product, and packaging. The

sterile compressed air applications are filtered to an efficiency of 99.9999+% at 0.01 microns, which is 30 times better than the accepted industry standard. Cahoon Farms safeguards their food product from any possible contamination that could lead to bacteria and mold growth. The investment in these filtration systems ensures Cahoon Farms' products will maintain superior taste, quality and freshness with an extended shelf life.

# Filters for the Food Industry

## Sterile Air Filter Rating Information

Balston grade SA filter cartridges, rated at 99.9999+% efficiency for 0.01 micron particles, is at least 30 times better than the accepted standard for sterile air filters developed by independent research organizations in the U.S. and U.K. (request bulletin TI-105 for a detailed discussion on Balston filter efficiency rating procedure, and Bulletin TI-935 for an independent test report on Balston Sterile Air Filters). Balston Sterile Air Filters are in full compliance with the requirements of the FDA.

## Explanation for 3 Stage Sterile Air System

<b>1st Stage: Grade DX</b>	Removal of large quantities of oil, water, and dirt from compressed air. Prefilter to Grade BX
<b>2nd Stage: Grade BX</b>	Complete removal of trace quantities of oil, water, and dirt down to 0.01 microns.
<b>3rd Stage: Grade SA</b>	Removal of bacteria providing sterile air.

## Flow Rates

Filter Housing Model	Port Size	Filter Cartridge Grade	Flow rates SCFM (Nm <sup>3</sup> /hr), at 7 psi (0.48 bar) drop at indicated line pressure. Refer to Principal Specification Charts in each product data sheet for maximum pressure rating of each housing PSIG						
			2 (0.1)	20 (1.4)	40 (2.8)	80 (5.5)	100 (6.9)	125 (8.6)	150 (10)
3B-2002N-3B1	1/4"	DX	9 (15)	19 (32)	39 (87)	51 (107)	63 (107)	76 (129)	90 (153)
3B-2003N-3B1	3/8"	BX	3 (5)	8 (14)	11 (36)	21 (42)	25 (42)	31 (53)	36 (61)
3B-2004N-3B1	1/2"	SA	---	8 (14)	11 (36)	21 (42)	25 (42)	31 (53)	36 (61)
3B-2104N-3B1	1/2"	DX	19 (32)	41 (70)	65 (192)	113 (233)	137 (233)	166 (282)	196 (333)
		BX	9 (15)	19 (32)	30 (87)	51 (107)	63 (107)	76 (129)	90 (153)
		SA	---	19 (32)	30 (87)	51 (107)	63 (107)	76 (129)	90 (153)
3B-2206N-3B1	3/4"	DX	37 (63)	78 (133)	123 (364)	214 (440)	259 (440)	315 (535)	371 (630)
		BX	10 (17)	21 (36)	34 (95)	56 (119)	70 (119)	85 (144)	101 (172)
		SA	---	21 (36)	34 (95)	56 (119)	70 (119)	85 (144)	101 (172)
3B-2208N-3B1	1"	DX	55 (93)	115 (195)	181 (533)	314 (646)	380 (646)	463 (787)	546 (928)
		BX	11 (19)	23 (39)	37 (109)	64 (131)	77 (131)	94 (160)	111 (189)
		SA	---	23 (39)	37 (109)	64 (131)	77 (131)	94 (160)	111 (189)
3B-2312N-3B1	1 1/2"	DX	98 (167)	203 (345)	319 (941)	554 (1138)	670 (1138)	816 (1386)	963 (1636)
		BX	22 (37)	46 (78)	74 (219)	129 (263)	155 (263)	189 (321)	223 (379)
		SA	16 (27)	33 (56)	52 (155)	91 (187)	110 (187)	134 (228)	158 (223)

1 For CRN rated assemblies add a "C" to the Model Number. Example: 3B-C2104N-3B1

# Filters for the Food Industry

## 3 Stage Sterile Air Filter Systems

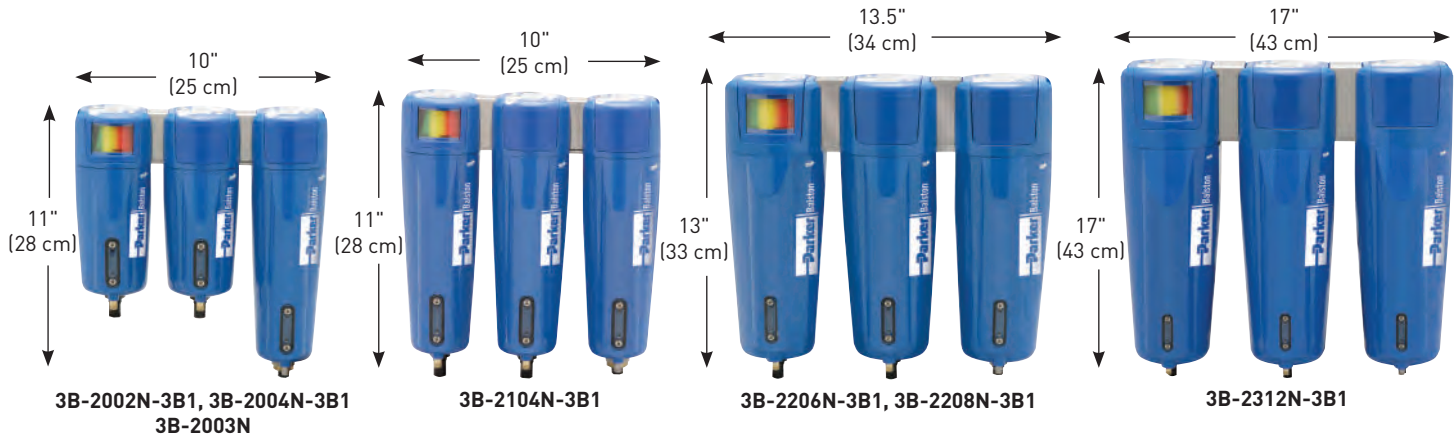

### Principal Specifications

Model	3B-2002, 2003, 2004	3B-2104	3B-2206	3B-2208	3B-2312
Port Size	1/4" NPT	1/2" NPT	3/4" NPT	1" NPT	1.5" NPT
Materials of Construction					
Head	Aluminum	Aluminum	Aluminum	Aluminum	Aluminum
Bowl	Aluminum	Aluminum	Aluminum	Aluminum	Aluminum
Internals	Aluminum	Aluminum	Aluminum	Aluminum	Aluminum
Seals	Buna-N Food Grade	Buna-N Food Grade	Buna-N Food Grade	Buna-N Food Grade	Buna-N Food Grade
Maximum Temperature (1)	130°F (54°C)	130°F (54°C)	130°F (54°C)	130°F (54°C)	130°F (54°C)
Maximum Pressure (2)	175 psig (12 barg)	175 psig (12 barg)	175 psig (12 barg)	175 psig (12 barg)	175 psig (12 barg)
Minimum Pressure (3)	15 psig (1 barg)	15 psig (1 barg)	15 psig (1 barg)	15 psig (1 barg)	15 psig (1 barg)
Shipping Weight	6.75 lbs. (3.1 kg)	7.5 lbs. (3.4 kg)	17.5 lbs. (8.0 kg)	17.5 lbs. 8.0 kg)	41.25 lbs. (18.8 kg)
Dimensions	10"W X 11"L	10"W X 11"L	13.5"W X 13"L	13"W X 13"L	17"W X 17"L

Notes:

1 Max. temperature with auto drain

2 Max. pressure with auto drain. Max. pressure with manual drain is 250 psig (17 barg).

3 Required for proper operation of auto drain.

### Ordering Information For assistance, call toll-free at 1-800-343-4048 8AM to 5PM Eastern Time

Assembly Ordering Information		Replacement Cartridge	
Model P/N		Box of 5	Box of 10
3B-2002N-3B1	1/4" 3-Stage (DX, BX, SA) Filter Assembly	5/100-12-DX	100-12-DX
3B-2003N-3B1	3/8" 3-Stage (DX, BX, SA) Filter Assembly	5/100-12-BX	100-12-BX
3B-2004N-3B1	1/2" 3-Stage (DX, BX, SA) Filter Assembly	5/100-12-SA	100-12-SA
3B-2104N-3B1	1/2" 3-Stage (DX, BX, SA) Filter Assembly	5/100-18-DX	100-18-DX
		5/100-18-BX	100-18-BX
		5/100-18-SA	100-18-SA
3B-2206N-3B1	3/4" 3-Stage (DX, BX, SA) Filter Assembly	5/150-19-DX	150-19-DX
		5/150-19-BX	150-19-BX
		5/150-19-SA	150-19-SA
3B-2208N-3B1	1" 3-Stage (DX, BX, SA) Stainless Assembly	5/150-19-DX	150-19-DX
		5/150-19-BX	150-19-BX
		5/150-19-SA	150-19-SA
3B-2312N-3B1	1 1/2" 3-Stage (DX, BX, SA) Stainless Assembly	5/200-35-DX	200-35-DX
		5/200-35-BX	200-35-BX
		5/200-35-SA	200-35-SA

4 2 each of mounting brackets are required for adequate support.

Filters for the Food Industry



# Filters for the Food Industry

## 3 Stage Sterile Air Filter Systems

### Balston Stainless Steel Compressed Air Filter Assemblies

Safeguard your operations from rust, pipescale, water, oil, and organisms. These filters will remove contaminants at a very high efficiency - up to 99.99% for 0.01 micron particles and droplets. Liquid releases from the filter cartridge to an automatic drain as rapidly as it enters the filter. This allows the filter to continue removing liquids for an unlimited time without loss of efficiency or flow capacity.

The final stage of filtration removes all viable organisms with an efficiency rating of 99.9999+ at 0.01 microns. Select 1/4" to 1" line filters are constructed of 304 stainless steel and are designed to hold up to the harshest environments.



### Product Features

- All 304 stainless steel construction, ideal standing up to aggressive washdown chemicals
- Low pressure drop
- Remove 99.9999+% of 0.01 micron particles of oil, water, and dirt from compressed air and other gases
- Remove all viable organisms
- Full compliance with FDA requirements
- USDA/FSIS accepted for use in federally inspected meat and poultry plants
- Continuously trap and drain liquids

### The Application

Compressed air is contaminated with compressor oil, water condensate, pipe scale and rust all of which provide the ideal environment and means to grow bacteria. This natural occurring contaminate can also effect the taste, appearance and shelf life of food product. The food processing and packaging industry utilizes compressed air extensively throughout their facilities. Compressed air is used to push and

propel product, cut and mix product in addition to packaging product.

Cahoon Farms in Walcott, New York uses Parker Balston three stage filtration systems for all their compressed air and sterile air applications. Cahoon Farms packages fresh sliced apples and cherries, dried apples, and other assorted dried fruits. Compressed air is used extensively throughout the facility servicing pneumatic equipment, slicing and mixing food product, and packaging. The sterile

compressed air applications are filtered to an efficiency of 99.9999+% at 0.01 microns which is 30 times better than the accepted industry standard. Cahoon Farms safeguards their food product from any possible contamination that could lead to bacteria and mold growth. The investment in these filtration systems ensures Cahoon Farms' products will maintain superior taste, quality and freshness with an extended shelf life.

Filters for the  
Food Industry

# Filters for the Food Industry

## 3 Stage Sterile Air Filter Systems

### Sterile Air Filter Rating Information

Balston grade SA filter cartridges, rated at 99.9999+% efficiency for 0.01 micron particles, is at least 30 times better than the accepted standard for sterile air filters developed by independent research organizations in the U.S. and U.K. (request bulletin TI-105 for a detailed discussion on Balston filter efficiency rating procedure, and Bulletin TI-935 for an independent test report on Balston Sterile Air Filters). Balston Sterile Air Filters are in full compliance with the requirements of the FDA.

### Steam Sterilization Procedure

In installations where the sterile air filter requires steam sterilization, we recommend the following procedures:

The steam sterilization pressure should not exceed 60 psig (4.1 barg). Preferably, it should be held to 40 psig (2.8 barg) or less. A typical sterilization cycle is 30 psig (2.1 barg) steam for 30 minutes. Steaming time can be increased as desired without harm to the filter cartridges. The steam flow should not exceed the normal air flow for the unit. To ensure no buildup of condensate in the housing, condensate should be drained from the filter by a condensate drain valve during the steaming process. The cleanliness of the steam is an important factor influencing the life of the sterile air filter cartridges. Parker strongly recommends using model 23 steam filters to ensure optimum operating life. When autoclaving, the grade SA filter cartridges will tolerate temperatures to 300°F (149°C) in dry gas. Viton or other heat resistant seals should be used in the housing.

### Explanation for 3 Stage Sterile Air System

<b>1st Stage: Grade DX</b>	Removal of large quantities of oil, water, and dirt from compressed air. Prefilter to Grade BX
<b>2nd Stage: Grade BX</b>	Complete removal of trace quantities of oil, water, and dirt down to 0.01 microns.
<b>3rd Stage: Grade SA</b>	Removal of bacteria providing sterile air.

### Flow Rates

Filter Housing Model	Port Size	Filter Cartridge Grade	Flow rates SCFM (Nm <sup>3</sup> /hr), at 7 psi (0.48 bar) drop at indicated line pressure. Refer to Principal Specification Charts in each product data sheet for maximum pressure rating of each housing PSIG									
			2	20	40	80	100	125	150	200	250	
3B-6002N-0A1	1/4"	DX	9 (15)	19 (32)	39 (66)	51 (87)	63 (107)	76 (129)	90 (153)	117 (199)	145 (246)	
		3B-6904N-0A1	1/2"	BX	3 (5)	8 (14)	11 (19)	21 (36)	25 (42)	31 (53)	36 (61)	47 (80)
3B-6004N-0A1	1/2"	SA	---	8 (14)	11 (19)	21 (36)	25 (42)	31 (53)	36 (61)	---	---	
		DX	19 (32)	41 (70)	65 (110)	113 (192)	137 (233)	166 (282)	196 (333)	257 (437)	316 (537)	
		BX	9 (15)	19 (32)	30 (51)	51 (87)	63 (107)	76 (129)	90 (153)	117 (199)	145 (246)	
3B-6006N-0A1	3/4"	SA	---	19 (32)	30 (51)	51 (87)	63 (107)	76 (129)	90 (153)	---	---	
		DX	37 (63)	78 (133)	123 (209)	214 (364)	259 (440)	315 (535)	371 (630)	484 (822)	596 (1013)	
		BX	10 (17)	21 (36)	34 (58)	56 (95)	70 (119)	85 (144)	101 (172)	131 (223)	162 (275)	
3B-6008N-0A1	1"	SA	---	21 (36)	34 (58)	56 (95)	70 (119)	85 (144)	101 (172)	---	---	
		DX	55 (93)	115 (195)	181 (308)	314 (533)	380 (646)	463 (787)	546 (928)	711 (1208)	877 (1490)	
		BX	11 (19)	23 (39)	37 (63)	64 (109)	77 (131)	94 (160)	111 (189)	144 (245)	178 (302)	
		SA	---	23 (39)	37 (63)	64 (109)	77 (131)	94 (160)	111 (189)	---	---	

# Filters for the Food Industry

## 3 Stage Sterile Air Filter Systems



### Principal Specifications

Model	3B-6002	3B-6904	3B-6004	3B-6006	3B-6008
Port Size	1/4" NPT	1/2" NPT	1/2" NPT	3/4" NPT	1" NPT
Materials of Construction					
Head	304 Stainless Steel	→	→	→	→
Bowl	304 Stainless Steel	→	→	→	→
Internals	Stainless Steel	→	→	→	→
Seals	Buna-N Food Grade	→	→	→	→
Maximum Temperature (1)	120°F (49°C)	→	→	→	→
Maximum Pressure (2)	175 psig (12 barg)	→	→	→	→
Minimum Pressure (3)	15 psig (1 barg)	→	→	→	→
Shipping Weight	10.5 lbs. (4.77 kg)	10.5 lbs. (4.77 kg)	11.8 lbs. (5.4 kg)	33.7 lbs. (15.3 kg)	34 lbs. (15.5 kg)
Dimensions	9"W X 3"D X 8"L	9"W X 3"D X 8"L	9"W X 3"D X 8"L	13"W X 4"D X 11"L	13"W X 4"D X 12"L

#### Notes:

- 1 Max. temperature with auto drain. Max. temperature with manual drain is 275°F (135°C).      2 Max. pressure with auto drain. Max. pressure with manual drain is 250 psi (17 bar).      3 Required for proper operation of auto drain.

### Ordering Information For assistance, call toll-free at 1-800-343-4048 8AM to 5PM Eastern Time

Assembly Ordering Information					
Model P/N	Mounting Bracket (stainless steel)	Replacement Cartridge		Mounting Bracket (stainless steel) (4)	
		Box of 5	Box of 10		
3B-6002N-0A1	1/4" 3-Stage (DX, BX, SA) Stainless Filter Assembly	5/100-12-DX 5/100-12-BX 5/100-12-SA	100-12-DX 100-12-BX 100-12-SA	C01-0094	
3B-6904N-0A1	1/2" 3-Stage (DX, BX, SA) Stainless Filter Assembly	5/100-12-DX 5/100-12-BX 5/100-12-SA	100-12-DX 100-12-BX 100-12-SA	C01-0094	
3B-6004N-0A1	1/2" 3-Stage (DX, BX, SA) Stainless Filter Assembly	5/100-18-DX 5/100-18-BX 5/100-18-SA	100-18-DX 100-18-BX 100-18-SA	C01-0094	
3B-6006N-0A1	3/4" 3-Stage (DX, BX, SA) Stainless Filter Assembly	5/200-176-DX 5/200-176-BX 5/200-176-SA	200-176-DX 200-176-BX 200-176-SA	C01-0094	
3B-6008N-0A1	1" 3-Stage (DX, BX, SA) Stainless Filter Assembly	5/200-185-DX 5/200-185-BX 5/200-185-SA	200-185-DX 200-185-BX 200-185-SA	C01-0094	

4 Two each of mounting brackets are required for adequate support.

Filters for the Food Industry

# Filters for the Food Industry

## Sterile Air Filters

Remove all viable organisms

USDA/FSIS accepted for use in federally inspected Meat and Poultry plants

Low pressure drop

Full compliance with FDA requirements

### Balston® Sterile Air Filters

Balston grade SA filter cartridges, rated at 99.9999+% efficiency for 0.01 micron particles, is at least 30 times better than the accepted standard for sterile air filters developed by independent research organizations in the U.S. and U.K. (request Bulletin TI-105 for a detailed discussion on Balston filter efficiency rating procedure, and Bulletin TI-935 for an independent test report on Balston Sterile Air Filters). Balston Sterile Air Filters are in full compliance with the requirements of the FDA.

Here's what one of your colleagues found:

A Balston sterile air filter assembly, consisting of Models 200X Series, was tested at the University of Massachusetts, Department of Food Science and Nutrition, under the direction of Professor David A. Evans, Ph.D.

"This sterile air system produced commercially sterile air and, to the limits of detection, no viable colonies of microorganisms were found".

- Professor David A. Evans, Ph.D.

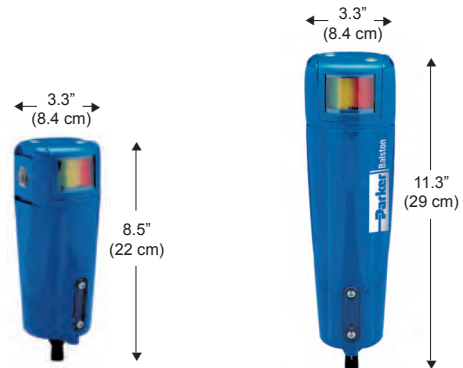

Model 200X Series

Model 2104 Series

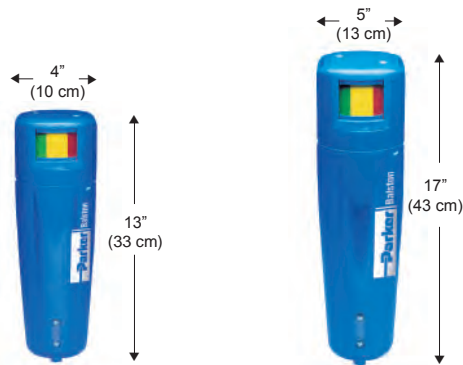

Model 2206, 2208

Model 2312



Model A15/80

# Filters for the Food Industry

## Sterile Air Filters

### Filter Cartridge Description

1st Stage: Grade DX	2nd Stage: Grade BX	3rd Stage: Grade SA
For removal of large quantities of oil, water, and dirt from compressed air. Prefilter to Grade BX.	For complete removal of trace quantities of oil, water, and dirt.	For removal of bacteria when providing sterile air.

### Physical Properties, Microfibre Filter Cartridges

Temperature Range	-150°F to 300°F (-100°C - 149°C)
Maximum Pressure	100 psi (6.9 bar), 60 psi (4 bar) for Grade SA Filter Differential Across Filter, Tubes
Inside-to-Outside Flow:	
Materials of Construction fluorocarbon resin binder.	Borosilicate glass microfibers with Resistant to water, all hydrocarbon and synthetic lubricants.

### Retention Efficiency

Grade	Efficiency for 0.01 Micron Particles and Droplets
DX	93% @ 0.01 µm
BX	99.99% @ 0.01 µm
SA	99.9999+% @ 0.01 µm

### Balston Filter Cartridge and Housing Selection

Balston provides two grades of coalescing filter cartridges, Grade DX and Grade BX. Singly or in tandem, these filters satisfy all requirements for removing liquid and solid contaminants from compressed air. These filters are recommended as prefilters in sterile air systems. The Balston Grade SA filter removes bacteria from compressed air. It is the final filter in a sterile air system.

### How to Select the Filter Cartridge and Housing

- 1 Decide which grade(s) of filter cartridges fits the application (see selection boxes at left).
- 2 Select the filter housing with a port size equal to the line size where the filter is to be located.
- 3 For a new installation in which the line size has yet to be selected, determine the gas flow rate and pressure at the point where the filter will be located, and then refer to the flow chart on the reverse side of this data sheet. The filter port size must be equal to or larger than the line size (when specified).
- 4 If the sterile air filter assembly requires steam sterilization, stainless steel filter assemblies specifically designed for in-line steam sterilization must be used. These assemblies are identified by the RED print in the flow chart on the next page.

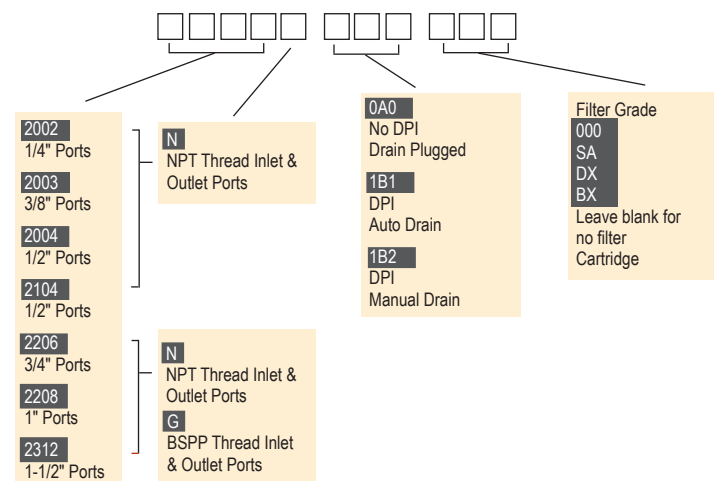

### How to Order the Filter Assembly

- 1 Build your own custom filter assembly using the guideline matrix to the left and specify your model number. Example: 1/2" filter with DPI and Auto Drain with Grade DX Filter = 2104N-1B1-DX.
- 2 Each assembly is shipped with the filter cartridge installed. To order additional filter cartridges, indicate the model number of the cartridges, and the grade. Examples 100-12-DX, 100-12-BX, or 100-12-SA, etc.

Filters for the  
Food Industry

# Filters for the Food Industry

## Sterile Air Filters

### Steam Sterilization Procedure

In installations where the sterile air filter requires steam sterilization, we recommend the following procedures:

The steam sterilization pressure should not exceed 60 psig. Preferably, it should be held to 40 psig (2.8 barg) or less. A typical sterilization cycle is 30 psig (2.1 barg) steam for 30 minutes. Steaming time can be increased as desired without harm to the filter cartridges. The steam flow should not exceed the normal air flow for the unit. To ensure no buildup of condensate in the housing, condensate should be drained from the filter by a condensate drain valve during the steaming process.

The cleanliness of the steam is an important factor influencing the life of the Sterile Air Filter cartridges. Parker strongly recommends using Model 23 Steam Filters to ensure optimum operating life (see steam filter section of this literature pack).

When autoclaving, the Grade SA filter cartridges will tolerate temperatures to 300°F (149°C) in dry gas. Viton or other heat resistant seals should be used in the housing.

Filter Assemblies Assemblies in <b>BLUE</b> are Steam Sterilization			Flow rates SCFM (NM <sup>3</sup> /hr), at 7 psi (0.48 bar) drop at indicated line pressure (over 3 stages) Refer to Principal Specification Charts in each product data sheet for maximum Recommended for pressure rating of each housing							
1st Stage	2nd Stage	3rd Stage	Port Size	20	40	60	80	100	125	150
2002N-1B1-DX	2002N-1B1-BX	2002N-OAO-SA <a href="#">A33B-SA</a>	1/4"	8 (14)	11 (19)	16 (27)	21 (36)	25 (42)	31 (53)	36 (61)
2104N-1B1-DX	2104N-1B1-BX	2104N-OAO-SA <a href="#">A45B-SA</a>	1/2"	19 (32)	30 (51)	41 (70)	51 (87)	63 (107)	76 (129)	90 (153)
2208N-1B1-DX	2208N-1B1-BX	2208N-OAO-SA <a href="#">A27/35B-SA</a>	1"	23 (39)	37 (63)	50 (85)	64 (109)	77 (131)	94 (160)	111 (189)
2312N-1B1-DX	2312N-1B1-BX	2312N-OAO-SA <a href="#">A27/80B-SA (1)</a>	1 1/2"	46 (78)	74 (126)	101 (172)	129 (219)	155 (263)	189 (321)	223 (379)
A15/80-DX	A15/80-BX	A15/80-SA <a href="#">A15/80S6-SA</a>	2"	94 (160)	148 (251)	202 (343)	256 (435)	310 (527)	378 (642)	445 (756)
AFF3-0128-HFC	AFF3-0128-HEC	AKC-0280-SA <a href="#">AKSB-0280-SA</a>	3"	190 (323)	300 (510)	400 (680)	510 (866)	620 (1053)	755 (1283)	890 (1512)
AFF4-0125-HFC	AFF4-0125-HEC	AKC-0480-SA <a href="#">AKSB-0480-SA</a>	4"	380 (646)	590 (1002)	810 (1376)	1020 (1733)	1240 (2107)	1510 (2565)	1780 (3024)
AFF6-0136-HFC	AFF6-0136-HEC	AKC-0880-SA <a href="#">AKSB-0880-SA</a>	6"	750 (1274)	1180 (2005)	1620 (2752)	2050 (3483)	2480 (4214)	3020 (5131)	3560 (6048)
AFF8-0428-HFC	AFF8-0428-HEC	AKC-1480-SA <a href="#">AKSB-1480-SA</a>	8"	1310 (2226)	2070 (3517)	2830 (4808)	3580 (6082)	4340 (7374)	5300 (9005)	6230 (10585)
AFF10-0728-HFC	AFF10-0728-HEC	AKC-2280-SA <a href="#">AKSB-2280-SA</a>	10"	2070 (3517)	3270 (5556)	4460 (7578)	5660 (9616)	6850 (11638)	8340 (14170)	9840 (16718)

Notes:

1 Two Type A27/80B-SA in parallel required.

# Filters for the Food Industry

## Sterile Air Filters - 1/4" to 2" Line Size

### Principal Specifications

Model	2002,2003,2004 (5)	2104 (5)	2206 (5)	2208 (5)	2312 (5)	A15/80
Port Size	1/4", 3/8", 1/2" NPT	1/2" NPT	3/4" NPT	1" NPT	1 1/2" NPT	2" NPT
Maximum Pressure	250 psig (17 barg) (1)	250 psig (17 barg) (1)	250 psig (17 barg) (1)	250 psig (17 barg) (1)	250 psig (17 barg) (1)	250 psig (17 barg) (1)
Maximum Temperature	170°F (77°C)	170°F (77°C)	130°F (54°C)	130°F (54°C)	130°F (54°C)	130°F (54°C)
Materials of Construction						
Head	Anod. Alum.	Anod. Alum.	Anod. Alum.	Anod. Alum.	Anod. Alum.	Anod. Alum.
Bowl	Anod. Alum.	Anod. Alum.	Anod. Alum.	Anod. Alum.	Anod. Alum.	Steel
Internals	Nylon	Nylon	Aluminum	Aluminum	Aluminum	St. Steel
Seals	Buna-N	Buna-N	Buna-N	Buna-N	Buna-N	Buna-N
Shipping Weight	2 lbs. (0.9 kg)	2.5 lbs. (1 kg)	8 lbs. (3.6 kg)	8 lbs. (3.6 kg)	15 lbs. (6.8 kg)	11 lbs. (5 kg)
Dimensions	3.3"W X 8.5"L (8cm X 22cm)	3.3"W X 11.3"L (8cm X 28cm)	4"W X 13"L (10cm X 33cm)	4"W X 13"L (10cm X 33cm)	5.0"W X 17"L (13cm X 43cm)	6.3"W X 28"L (16cm X 71cm)

### Ordering Information

For assistance, call toll-free at 1-800-343-4048 8AM to 5PM Eastern Time

Model	2002,2003,2004 (5)	2104 (5)	2206 (5)	2208 (5)	2312 (5)	A15/80
Assembly with Grade DX Filter Cartridge	200?-1B1-DX	2104N-1B1-DX	2206N-1B1-DX	2208N-1B1-DX	2312N-1B1-DX	A15/80-DX
Assembly with Grade BX Filter Cartridge	200?-1B1-BX	2104N-1B1-BX	2206N-1B1-BX	2208N-1B1-BX	2312N-1B1-BX	A15/80-BX
Assembly with Grade SA Filter Cartridge & Support Core	200?-OAO-SA	2104N-OAO-SA	2206N-OAO-SA	2208N-OAO-SA	2312N-OAO-SA	A15/80-SA
Differential Pressure Indicator (optional)	Included (2)	Included (2)	Included (2)	Included (2)	Included (2)	Included (2)
Filter Cartridges (3)						
Number Required	1	1	1	1	1	1
Box of 3 (4)	3/100-12-□	3/100-18-□	3/150-19-□	3/150-19-□	3/200-35-□	3/200-80-□
Box of 5 (4)	5/100-12-□	5/100-18-□	5/150-19-□	5/150-19-□	5/200-35-□	5/200-80-□
Box of 10 (4)	100-12-□	100-18-□	150-19-□	150-19-□	200-35-□	200-80-□

#### Notes:

1 Maximum pressure ratings are for temperatures to 130°F (54°C). Please consult factory for maximum pressure ratings at elevated temperatures.

2 Differential Pressure Indicator is not supplied with assemblies containing Grade SA

Cartridges. Maximum pressure rating for 41-082 is 250 psig (17 barg). The DPI is sensitive in the range of 0-5 psi (0-0.34 bar) differential.

3 To order filter cartridges, indicate the grade of filter cartridge by placing the appropriate

letter after the ordering number. Examples: 5/100-12-DX, 100-18-BX, 150-19-SA.

4 Grades BX, DX are available only in boxes of 5 and 10. Grade SA is available in boxes of 3 and 10.

5 Lifetime (20 year) warranty included. Contact your local representative for details.

### How to Order the Filter Assembly\*

Build your own custom filter assembly using the guideline matrix below and specify your model number. Example: 1/2" filter with DPI and Auto Drain with Grade DX Filter = 2104N-1B1-DX.

\*Consult Factory. Not all configurations are available.

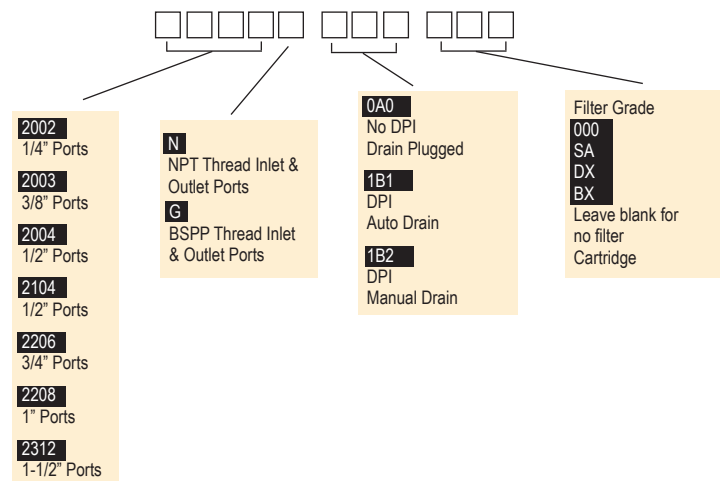

# Filters for the Food Industry

## 3" to 10" Line Size Filters

### New LF/FF Series Multiple Cartridge Filter Assemblies

These filter assemblies provide high efficiency filtration of compressed air and other compressed gases at very high flow rates. With inlet and outlet ports accommodating 3" to 10" pipe sizes, the new LF/FF Series housings are capable of flow rates up to a maximum capacity of 37,350 SCFM (63,458 m<sup>3</sup>/h) at 100 psig (6.9 barg). The standard carbon steel units, which are generally in stock (through 6" line sizes), have pressure ratings up to 250 psig (17.2 barg).

All LF/FF series housings are ASME Code Stamped for the rated maximum operating pressure. All FF Series vessels have built-in legs for floor mounting. Selected models have swing bolt enclosures for easy access to the internals. The filter cartridges in all models are sealed by tightening the threaded retainer cap onto the rigid tie rod, ensuring a leak tight seal on both ends of the cartridge.

Each assembly is equipped with a carbon steel automatic float drain, differential pressure indicator, and a set of filter cartridges (except where noted).



#### Benefits

<i>Low Pressure Drop</i>	<i>Heat and Chemical Resistant</i>
<i>Lower Change out/Labor Costs</i>	<i>No Wet Zone</i>
<i>Lower Energy Costs</i>	<i>Oleophobic/Hydrophobic</i>
<i>High Dirt Holding Capacity</i>	<i>High Burst Strength</i>

#### Calculation with Part-Load Operation (100 hp compressor)

Annual Electricity Costs =  
 [(Motor full-load brake horsepower) x (0.746 kW/hp)  
 x (Annual Hours of Operation) x (Electricity Cost in \$/kWh)] x [(Percent of time running fully loaded) + (0.30) x (Percent of time running unloaded)]  
 For example:  
 Full load motor efficiency = 90%  
 Motor full load bhp = 100 hp  
 Annual hours of operation = 8,760 hours (3-shift, continuous operation)  
 Runs 65% of the time fully loaded, 35% of the time unloaded  
 Unloaded operation consumes 30 percent of the electricity of fully loaded operation  
 Cost of electricity = \$0.10/kWh  
**Annual electricity costs =**  
 [(100 hp) x (0.746 hp/kW) x (8,760 hrs) x \$0.10/kWh / 0.9] x [0.65 + (0.30) x (0.35)] = **\$54,272.00**



# Filters for the Food Industry

## 3" to 10" Line Size Filters

### HFC Savings

Annual electricity costs to operate a 100 HP Compressor can be as high as \$50,000. Pressure loss in the system adds to this expense. For a system operating at 100 psig (7 barg) that loses 2 psig (0.14 barg) of pressure through a filter, requires an additional 1% in operating energy costs (1).

Installing a single stage HFC Filter in place of a standard brand X filter, will reduce the pressure drop by 2+ psi (0.14 barg).

Based on a standard 100 HP (74.6 kW) compressor operating at a 65% load cycle, a 1% reduction in annual operating costs would be equal to \$542.00

**NEW!**

### High Flow Coalescing Filter Media HFC Grade

**Efficiency: 99.5% @ 0.5 micron**

Balston's HFC media consists of two layers. The outer layer features a dense matrix of glass fibers. It provides highly efficient coalescing aerosol removal and very low pressure drop. The inner layer, or initial stage of filtration, effectively traps dirt particles, protecting and extending the life of the outer layer. A metal retainer is used for strength and stability. This media is used in bulk coalescing applications and when relatively high efficiency and low pressure drop are required.



### High Efficiency Coalescing Media HEC Grade

**Efficiency: 99.97% @ 0.01 micron**

Air Flow: Inside to Outside

This coalescing element is composed of an epoxy saturated borosilicate glass micro-fiber tube. The HEC grade filter has a pleated cellulose inner layer as a built-in prefilter. This element is metal retained for added strength, and includes a synthetic fabric layer.



HEC filters are used when "total removal of liquid aerosols and suspended fines" is required. Because of its overall performance characteristics, this grade is most often recommended.

The HEC element is great prefilter protection for desiccant air dryers. This element prevents oil or varnish from coating the desiccant, while maintaining the dryer efficiency.

(1) Compressed Air Challenge, Doc # F9-1, April, 1998-Rev.0.

### HFC MEDIA Max. Rated Flows (SCFM) at Various Operating Pressures (0.25 psi pressure drop)

Model Number	2 psig	20 psig	40 psig	80 psig	100 psig	125 psig	150 psig	175 psig	200 psig	220 psig	250 psig
AFF3-0128-HFC	363	753	1187	2056	2490	3033	3575	4118	4661	5095	5746
AFF4-0125-HFC	483	1004	1583	2741	3320	4044	4767	5491	6215	6793	N/A
AFF6-0136-HFC	725	1507	2375	4112	4980	6065	7151	8236	9322	10190	11493
AFF6-0328-HFC	1088	2260	3562	6167	7470	9098	10726	12354	13983	15285	N/A
AFF8-0428-HFC	1450	3013	4750	8223	9960	12131	14302	16472	18644	20380	22984
AFF10-0728-HFC	2538	5273	8312	14391	17430	21229	25028	28826	32627	35665	40222
AFF12-1128-HFC	3988	8286	13062	22614	27390	33360	39330	45298	51271	56045	63206
AFF16-1528-HFC	5438	11299	17812	30837	37350	45491	53632	61770	69915	76425	86190

### HEC MEDIA Max. Rated Flows (SCFM) at Various Operating Pressures (1.5 psi pressure drop)

Model Number	2 psig	20 psig	40 psig	80 psig	100 psig	125 psig	150 psig	175 psig	200 psig	220 psig	250 psig
AFF3-0128-HEC	218	454	715	1238	1500	1827	2154	2481	2808	3069	3462
AFF4-0125-HEC	291	605	954	1651	2000	2436	2872	3308	3744	4092	N/A
AFF6-0136-HEC	437	908	1431	2477	3000	3654	4308	4962	5616	6139	6923
AFF6-0328-HEC	654	1362	2145	3714	4500	5481	6462	7443	8424	9207	N/A
AFF8-0428-HEC	872	1816	2860	4952	6000	7308	8616	9924	11232	12276	13848
AFF10-0728-HEC	1526	3178	5005	8666	10500	12789	15078	17367	19656	21483	24234
AFF12-1128-HEC	2398	4994	7865	13618	16500	20097	23694	27291	30888	33759	38082
AFF16-1528-HEC	3270	6810	10725	18570	22500	27405	32310	37215	42120	46035	51930

Filters for the  
Food Industry

# Filters for the Food Industry

## Sterile Air Filters - 3" to 10" Line Size

**Remove all viable organisms**

**Full compliance with FDA requirements**

**High flow rates**

**USDA/FSIS accepted for use in federally inspected meat and poultry plants**

### Balston® Sterile Air Filters

Balston grade SA filter cartridges, rated at 99.9999+% efficiency for 0.1 micron particles, is at least 30 times better than the accepted standard for sterile air filters developed by independent research organizations in the U.S. and U.K. (request Bulletin TI-105 for a detailed discussion on Balston filter efficiency rating procedure, and Bulletin TI-935 for an independent test report on Balston Sterile Air Filters). Balston Sterile Air Filters are in full compliance with the requirements of the FDA.

#### ***Here's what one of your colleagues found:***

A Balston sterile air filter assembly, consisting of 1/4" Models of Grade DX, Grade BX, and Grade SA were tested at the University of Massachusetts, Department of Food Science and Nutrition, under the direction of Professor David A. Evans, Ph.D.

*"This sterile air system produced commercially sterile air and, to the limits of detection, no viable colonies of microorganisms were found".*

- Professor David A. Evans, Ph.D



Model AKC-0280



Model AKC-1480

# Filters for the Food Industry

## Sterile Air Filters - 3" to 10" Line Size

### Principal Specifications

Model	AKC-0280	AKC-0480	AKC-0880	AKC-1480	AKC-2280
Port Size	3" Flange	4" Flange	6" Flange	8" Flange	10" Flange
Maximum Pressure	250 psig (17 barg) (1)	250 psig (17 barg) (1)	200 psig (14 barg) (1)	200 psig (14 barg) (1)	200 psig (14 barg) (1)
Maximum Temperature	230°F (110°C) (2)	230°F (110°C) (2)	250°F (110°C) (2)	250°F (110°C) (2)	250°F (110°C) (2)
Materials of Construction	Carbon steel vessel with 303 Stainless Steel filter tube holders and Buna N seals.				
Closure Type	Flat flanged top with swing bolts and Buna N "O" rings.				
Shipping Weight	132 lbs. (60 kg)	210 lbs. (95 kg)	360 lbs. (163 kg)	590 lbs. (268 kg)	880 lbs. (400 kg)
Dimensions	36"H X 16"W (91cm X 40cm)	36"H X 21"W (91cm X 53cm)	38"H X 25"W (97cm X 64cm)	54"H X 34"W (137cm X 86cm)	56"H X 36"W (142cm X 91cm)
Flange Center Line to Floor Dimension	7.75" (20cm)	6.25" (11cm)	7.5" (19cm)	16.25" (41cm)	17.25" (44cm)

### Ordering Information (3)

For assistance, call toll-free at 1-800-343-4048 8AM to 5PM Eastern Time

Model	AKC-0280	AKC-0480	AKC-0880	AKC-1480	AKC-2280
Assembly with Grade SA Filter Cartridge & Support Core	AKC-0280-SA	AKC-0480-SA	AKC-0880-SA	AKC-1480-SA	AKC-2280-SA
Filter Cartridges (4)					
Number Required	2	4	8	14	22
Box of 3	3/200-80-□	3/200-80-□	3/200-80-□	3/200-80-□	3/200-80-□
Box of 5	5/200-80-□	5/200-80-□	5/200-80-□	5/200-80-□	5/200-80-□
Box of 10	200-80-□	200-80-□	200-80-□	200-80-□	200-80-□

#### Notes:

1 Vessel is ASME Section VIII, Division 1 code stamped for rated pressure. All AKC series housings have CRN registration numbers assigned in all Canadian provinces.

2 Maximum operating temperature may be limited by seal material. Consult factory for recommendations at elevated temperatures.

3 Filter assemblies are shipped complete with automatic drain, filter cartridges, and differential pressure indicator.

#### Automatic Drain

The maximum operating pressure for the

Model 20-211 Automatic Drain is 400 psig (28 barg). Minimum operating pressure is 10 psig (0.7 barg).

#### Differential Pressure Indicator

The maximum operating pressure for the Differential Pressure Indicator Model 41-071 is 250 psig (14 barg). The DPI is sensitive in the range of 0-5 psi (0-0.3 bar).

The Automatic Drain and Differential Pressure Indicator are not included with assemblies containing SA cartridges.

4 To order filter cartridges, indicate the grade of filter cartridge by placing the appropriate letter after the ordering number. Examples: 5/100-12-SA, 100-18-SA, 150-19-SA.

# Filters for the Food Industry

## Steam Sterilizable Sterile Air Filters - 1/4" to 1" Line Size

Remove all viable organisms

In-line steam sterilization

Low pressure drop

Full compliance with FDA requirements

USDA/FSIS accepted for use in federally inspected meat and poultry plants



Model A33B-SA



Model A45B-SA



Model A27/35B-SA, A27/80B-SA

### Balston® Sterile Air Filters

Balston grade SA filter cartridges, rated at 99.9999+% efficiency for 0.1 micron particles, is at least 30 times better than the accepted standard for sterile air filters developed by independent research organizations in the U.S. and U.K. (request Bulletin TI-105 for a detailed discussion on Balston filter efficiency rating procedure, and Bulletin TI-935 for an independent test report on Balston Sterile Air Filters). Balston Sterile Air Filters are in full compliance with the requirements of the FDA.

#### Here's what one of your colleagues found:

A Balston sterile air filter assembly, consisting of 1/4" Models of Grade DX, Grade BX, and Grade SA were tested at the University of Massachusetts, Department of Food Science and Nutrition, under the direction of Professor David A. Evans, Ph.D.

*"This sterile air system produced commercially sterile air and, to the limits of detection, no viable colonies of microorganisms were found".*

- Professor David A. Evans, Ph.D

# Filters for the Food Industry

## Steam Sterilizable Sterile Air Filters - 1/4" to 1" Line Size

### Principal Specifications

Model	A33B	A45B	A27/35B	A27/80B
Inlet and Outlet Ports	1/4" NPT	1/2" NPT	1" NPT	1" NPT
Drain Port	1/8" NPT (1)	1/8" NPT (1)	1/4" NPT (1)	1/4" NPT (1)
Materials of Construction				
Head	316SS	316SS	316SS	316SS
Bowl	316SS	316SS	316SS	316SS
Internals	316SS	316SS	316SS	316SS
Seals	Viton (2)	Viton (2)	Viton (2)	Viton (2)
Maximum Temperature	400°F (204°C)	400°F (204°C)	400°F (204°C)	400°F (204°C)
Maximum Pressure	425 psig (29 barg) (3)	250 psig (17 barg) (3)	800 psig (55 barg) (3)	800 psig (55 barg) (3)
Maximum Steam Pressure for Sterilization	60 psig (4 barg)	60 psig (4 barg)	60 psig (4 barg)	60 psig (4 barg)
Shipping Weight	3 lbs. (1 kg)	5 lbs. (2 kg)	16 lbs. (7 kg)	20 lbs. (9 kg)
Dimensions	2.6"Dia X 4.9"L (7cm X 12cm)	2.6"Dia. X 8.4"L (7cm X 21cm)	4.0"Dia. X 16"L (10cm X 40cm)	4.0"Dia. X 27"L (10cm X 69cm)

### Ordering Information

For assistance, call toll-free at 1-800-343-4048 8AM to 5PM Eastern Time

Model	A33B	A45B	A27/35B	A27/80B
Assembly with Grade SA Filter Cartridge	A33B-SA	A45B-SA	A27/35B-SA	A27/80B-SA
Filter Cartridges:				
Number Required	1	1	1	1
Box of 3	3/100-12-SA	3/100-25-SA	3/200-35-SA	3/200-80-SA
Box of 10	100-12-SA	100-25-SA	200-35-SA	200-80-SA

#### Notes:

- 1 Condensate drain valve required. Supplied by customer.
- 2 Constructed of food grade Viton.
- 3 Maximum pressure ratings are for temperatures to 130°F (54°C). Please consult factory for maximum pressure ratings at elevated temperatures.

# Filters for the Food Industry

## Steam Sterilizable Sterile Air Filters - 2" to 10" Line Size

Remove all viable organisms

In-line steam sterilization

High flow rates

Full compliance with FDA requirements

USDA/FSIS accepted for use in federally inspected meat and poultry plants

### Balston® Sterile Air Filters

Balston grade SA filter cartridges, rated at 99.9999+% efficiency for 0.01 micron particles, is at least 30 times better than the accepted standard for sterile air filters developed by independent research organizations in the U.S. and U.K. (request Bulletin TI-105 for a detailed discussion on Balston filter efficiency rating procedure, and Bulletin TI-935 for an independent test report on Balston Sterile Air Filters). Balston Sterile Air Filters are in full compliance with the requirements of the FDA.



Model AKSB-0280-3-SA



Model AKSB-1480-SA

#### Here's what one of your colleagues found:

A Balston sterile air filter assembly, consisting of 1/4" Models of Grade DX, Grade BX, and Grade SA were tested at the University of Massachusetts, Department of Food Science and Nutrition, under the direction of Professor David A. Evans, Ph.D.

*"This sterile air system produced commercially sterile air and, to the limits of detection, no viable colonies of microorganisms were found".*

- Professor David A. Evans, Ph.D

# Filters for the Food Industry

## Steam Sterilizable Sterile Air Filters - 2" to 10" Line Size

### Principal Specifications

Model	AKSB-0280-2-SA	AKSB-0280-SA	AKSB-0480-SA	AKSB-0880-SA	AKSB-1480-SA	AKSB-2280-SA
Port Size	2" Flange	3" Flange	4" Flange	6" Flange	8" Flange	10" Flange
Materials of Construction	316SS	316SS	316SS	316SS	316SS	316SS
Seals	Viton (1)	Viton (1)	Viton (1)	Viton (1)	Viton (1)	Viton (1)
Maximum Pressure	200 psig (14 barg) (2)	200 psig (14 barg) (2)	200 psig (14 barg) (2)	200 psig (14 barg) (2)	200 psig (14 barg) (2)	200 psig (14 barg) (2)
Maximum Temperature	200°F (93°C)	200°F (93°C)	200°F (93°C)	200°F (93°C)	200°F (93°C)	200°F (93°C)
Maximum Steam Pressure for Sterilization	60 psig (4 barg)	60 psig (4 barg)	60 psig (4 barg)	60 psig (4 barg)	60 psig (4 barg)	60 psig (4 barg)
Shipping Weight	140 lbs. (64 kg)	140 lbs. (64 kg)	210 lbs. (95 kg)	360 lbs. (163 kg)	590 lbs. (268 kg)	880 lbs. (400 kg)
Dimensions	16"W X 36"L (41cm X 91cm)	16"W X 36"L (41cm X 91cm)	20"W X 36"L (53cm X 91cm)	25"W X 38"L (64cm X 97cm)	34"W X 54"L (86cm X 137cm)	36"W X 56"L (91cm X 142cm)

### Ordering Information

For assistance, call toll-free at 1-800-343-4048 8AM to 5PM Eastern Time

Model	AKSB-0280-2	AKSB-0280-3	AKSB-0480	AKSB-0880	AKSB-1480	AKSB-2280
Assembly with Grade SA Filter Cartridge	AKSB-0280-2-SA	AKSB-0280-SA	AKSB-0480-SA	AKSB-0880-SA	AKSB-1480-SA	AKSB-2280-SA
Filter Cartridges:						
Box of 3	3/200-80-SA	3/200-80-SA	3/200-80-SA	3/200-80-SA	3/200-80-SA	3/200-80-SA
Box of 10	200-80-SA	200-80-SA	200-80-SA	200-80-SA	200-80-SA	200-80-SA
Number per housing	2	2	4	8	14	22

#### Notes:

- 1 Constructed of food grade Viton.
- 2 Vessel is ASME Section VIII Division 1 Code stamped for rated pressure.

# Cabinet Dryers for Wash Down Areas

## Eliminate Moisture Problems in Electrical Cabinets and Motors

### Balston CD Series Cabinet Dryers

You demand a lot from your electrical cabinets and motors. They are subject to nightly high pressure, hot wash downs and then expected to remain dry in a refrigerated area. Over time most cabinets develop moisture inside which leads to premature component failures. This interrupts production and costs you money. Expensive vortex coolers or heaters don't work. Vortex coolers use a considerable amount of air and have a high operating cost. Heaters simply raise the humidity of the air inside the cabinet and don't eliminate the moisture.

The Parker Balston Cabinet Dryer serves to reduce the humidity inside the cabinet to less than 10% RH. Any water that infiltrates the cabinet evaporates quickly. Electrical components stay clean and dry which prolongs their life.

### Avoid costly down time!

Many plants struggle with moisture problems by managing downtime emergencies. Emergencies divert limited maintenance personnel and disrupt production at the cost of thousands of dollars per hour. The Cabinet Dryer reduces these maintenance and lost production costs by 80% or more. A typical customer will see savings of \$10K - 15K per year. The Cabinet Dryer will operate continuously and reliably without operator attention thus freeing up valuable maintenance personnel who are better devoted to important routine maintenance work rather than daily emergency response.

### Product Features:

- Designed specifically for wash down areas
- Protects electrical cabinet components from damage caused by water and high humidity
- Minimizes pools of water inside cabinets
- Positive pressure keeps dust out
- Adds no heat to the cabinet
- Reduces cabinet humidity to less than 10% RH
- Requires no electricity, low operating costs
- Easy to install and maintain
- Quiet operation
- Protect motors, touch screens, drives and other critical components



### Do Your Cabinets Look Like This?



Corrosion leads to premature component failure



Water accumulation in electrical cabinet

### A Cabinet Dryer will keep your cabinets looking as good as new

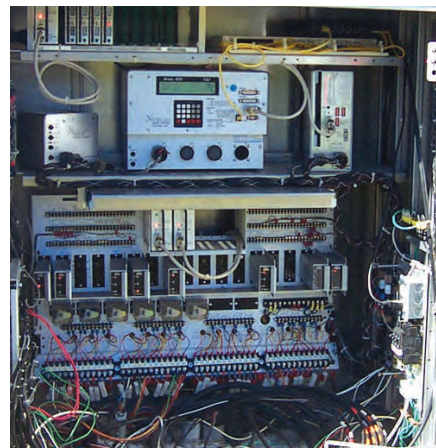

Filters for the Food Industry



# Cabinet Dryers for Wash Down Areas

## Eliminate Moisture Problems in Electrical Cabinets and Motors

### Principal Specifications

Model Number	CD0005	CD0010	CD0030
Cabinet Size Range (2)	0 - 4 FT <sup>3</sup> (0 - 0.11m <sup>3</sup> )	4 - 12 FT <sup>3</sup> (0.11m <sup>3</sup> - 0.34m <sup>3</sup> )	12 - 36 FT <sup>3</sup> (0.34m <sup>3</sup> - 1m <sup>3</sup> )
Min/Max Inlet Air Temp	40°F/120°F (4°C/49°C)	40°F/120°F (4°C/49°C)	40°F/120°F (4°C/49°C)
Min/Max Ambient Air Temp	35°F/120°F (2°C/49°C)	35°F/120°F (2°C/49°C)	35°F/120°F (2°C/49°C)
Air Consumption	0.6 SCFM (1 Nm <sup>3</sup> /hr) (17 slpm)	1.25 SCFM (2 Nm <sup>3</sup> /hr) (35.4 slpm)	3.5 SCFM (6 Nm <sup>3</sup> /hr) (99 slpm)
Min/Max Air Pressure	60 psi/150 psi (4.1 BAR/10.3 BAR)	60 psi/150 psi (4.1 BAR/10.3 BAR)	60 psi/150 psi (4.1 BAR/10.3 BAR)
Delivered Dew Point	-7°F(-22°C) (1)	-7°F(-22°C) (1)	-7°F(-22°C) (1)
Inlet Port Size	1/4" NPT	1/4" NPT	1/4" NPT
Outlet Port Size	1/4" NPT	1/4" NPT	1/4" NPT
Electrical Requirements	None	None	None
Dimensions	3"w x 9.2"h x 2"d (7.6cm x 2.34cm x 5cm)	3"w x 15.2"h x 2"d (7.6cm x 38.6cm x 5cm)	4.6"w x 15.3"h x 2.9"d (11.7cm x 38.9cm x 7.4cm)
Shipping Weight	1.5 lbs (0.68 kg)	2 lbs (0.9 kg)	2.5 lbs (1.1 kg)

**Notes:**

- 1 Delivered dewpoint is specified for saturated inlet air at 100°F (38°C) and 100 psig (6.9 BAR).
- 2 If the cabinet is not tightly sealed, consider upsizing to the next module size.
- 3 Filtration efficiency: 99.99% at 0.01micron.
- 4 For heavily contaminated air lines, install additional prefiltration.

### Ordering Information For assistance call toll free at 800-343-4048, 8AM to 5PM EST

Model Number	CD0005	CD0010	CD0030
Replacement Filter Elements	070-063-BX	070-063-BX	070-063-BX
Replacement Auto Drain	C02-2392	C02-2392	C02-2392



### Here's what our customers say:

"We tried heaters, fans and vortex coolers, our only solution was to use a Parker Balston dryer that continuously purges the cabinet with dry air."

- Lee Clarkson  
Ross Industries

"I've been with Smithfield for 15 years and we've had issues with wet electrical cabinets for 15 years. We installed the cabinet dryer on our wettest cabinet to see if it would work. Our Multivac™ packager was having significant issues. It was out of service 2-3 times per week due to condensation inside the cabinet. When we installed the dryer we noticed a difference right away. The water droplets on the walls of the cabinet were gone and our downtime from moisture was completely eliminated. It worked just like they told me."

Maintenance Manager  
Large Meat Processing Plant

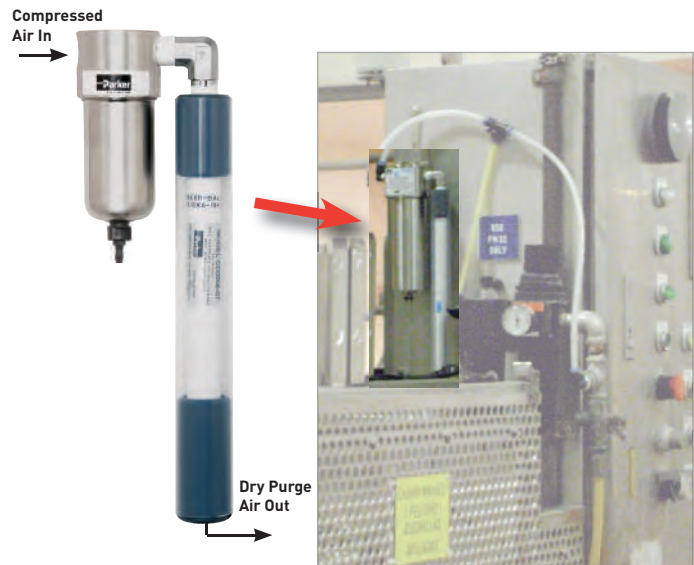

Filters for the Food Industry



## Application Notes

# Compressed Air Dryers

## Balston Compressed Air Dryers

Balston offers both membrane and PSA technology. Balston Membrane Air Dryers combine superior coalescing technology with a proven, innovative membrane system to supply clean, dry compressed air with dewpoints as low as  $-40^{\circ}\text{F}$  ( $-40^{\circ}\text{C}$ ).

Balston PSA Compressed Air Dryers will reduce the dewpoint of compressed air to  $-100^{\circ}\text{F}$  ( $-73^{\circ}\text{C}$ ). Each dryer is delivered complete and ready for easy installation.



## Product Features

- Unattended 24 hour operation
- Compact
- Membrane and PSA technologies available
- Silent operation
- No desiccant to change
- Easy to install and operate

Moisture Sensitive Point of Use Areas



Main Ring Applications



Process and Production Equipment

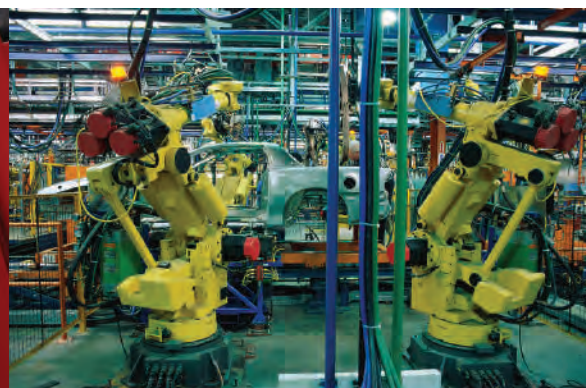

# Compressed Air Dryers

## Membrane Air Dryers



Balston  
Membrane Air Dryers

### State-of-the-Art Membrane Technology

Water vapor from the compressed air supply passes through the hollow fibers of the membrane. At the same time, a small portion of the dry air product is redirected along the length of the fibers to sweep out the water vapor laden air which has permeated the membrane. The moisture-laden sweep gas is then vented to the atmosphere, and clean, dry air is supplied to the application. The drying power of the membrane is controlled by varying the compressed air flow rate and pressure. The Balston Membrane Air Dryer is designed to operate continuously, 24 hours per day, 7 days per week. The only maintenance required is changing the prefilter cartridge twice a year. This semi-annual maintenance takes approximately 5 minutes.

**Offer a reliable, efficient, and economical alternative to pressure swing and refrigerant dryer technologies**

**Require no electricity thus lowering operating costs**

**Dewpoints as low as -40°F (-40°C) prevent freeze-ups**

**Explosion proof**

**Silent operation**

**No desiccant to change**

### Membrane Air Dryers

Balston Membrane Air Dryers combine a superior coalescing technology with a proven, innovative membrane system to supply clean, dry compressed air with dewpoints as low as -40°F (-40°C). The Membrane Air Dryers are engineered for easy installation, operation, and long term reliability. The dryers incorporate high efficiency coalescing filtration and the highest efficiency membrane available to provide low cost operation and minimal maintenance.

### Applications

Low dewpoint instrument air	Prevention of freeze-ups
Pneumatic equipment	Dry air for hazardous areas
Pressurizing electronic cabinets	General laboratory air supply
Analytical instrumentation	Protect electrical panel components from moisture damage
Instrument air for analyzer buildings	

**- "We have not had one shutdown due to freeze-ups since the Balston Membrane Dryer was installed."**

Peter Vogt  
International Filler Corp.

# Compressed Air Dryers

## Membrane Air Dryer - Principle of Operation

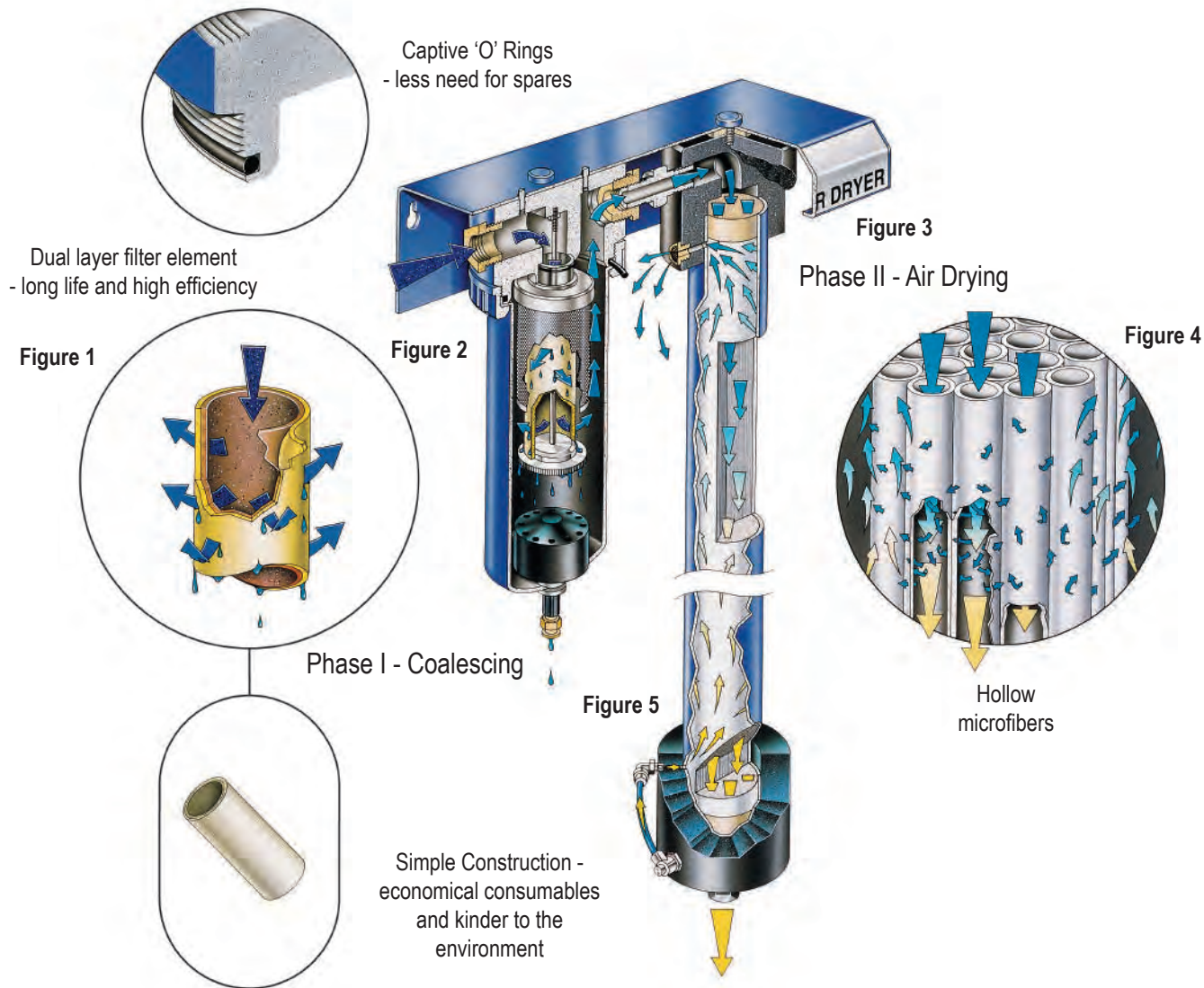

### Phase I - Coalescing Filtration

Prior to entering the membrane drying module, the compressed air passes through a high efficiency coalescing filter to remove oil and water droplets and particulate contamination with an efficiency of 99.99% at 0.01 micron. The liquids removed by the filter cartridge continuously drip from the filter cartridge into the bottom of the housing, where they are automatically emptied by an autodrain assembly [see Fig. 1 and Fig. 2]. The air leaving the prefilter, therefore, is laden only with water vapor, which will be removed in the membrane module.

### Phase II - Drying

The water vapor in the compressed air is removed by the principle of selective permeation through a membrane [see Fig. 3]. The membrane module consists of bundles of hollow membrane fibers [see Fig. 4], each permeable only to water vapor. As the compressed air passes through the center of these fibers, water vapor permeates through the walls of the fiber, and dry air exits from the other end of the fiber. A small portion of the dry air (regeneration flow) is redirected along the length of the membrane fiber to carry away the moisture-laden air which surrounds the membrane fibers. The remainder of the dry air is piped to the application.

# Compressed Air Dryers

## Membrane Air Dryers for -40°F (-40°C) Dewpoint



Model 76-01



Model 76-02



Model 76-10



Model 76-20



Model 76-40

### Flow Rates

Outlet Flow in SCFM (Nm<sup>3</sup>/hr) at Indicated Operating Pressure for -40°F (-40°C) Atmospheric Dewpoint

Pressure Dewpoint	60 psig (4.1 barg) -40°F(-40°C)	80 psig (5.5 barg) -40°F(-40°C)	100 psig (6.9 barg) -40°F(-40°C)	120 psig (8.3 barg) -40°F(-40°C)	140 psig (9.7 barg) -40°F(-40°C)
Model 76-01	.3 (0.5)	.6 (1.0)	1 (1.7)	1.3 (2.2)	1.7 (2.9)
Model 76-02	.6 (1.0)	1 (1.7)	2 (3.4)	2.4 (4.1)	3.4 (5.8)
Model 76-10	3.0 (5.1)	5 (8.5)	10 (17)	13 (22)	17 (29)
Model 76-20	6.0 (10)	10 (17)	20 (34)	26 (44)	34 (58)
Model 76-40	12.0 (20)	20 (34)	40 (68)	52 (88)	68 (116)

### Membrane Module Regeneration Flow

Regeneration Flow in SCFM (Nm<sup>3</sup>/hr) at Indicated Operating Pressure and all dewpoints

Pressure Dewpoint	60 psig (4.1 barg)	80 psig (5.5 barg)	100 psig (6.9 barg)	120 psig (8.3 barg)	140 psig (9.7 barg)
Model 76-01	.2 (.3)	.2 (0.3)	.3 (0.5)	.3 (0.5)	.3 (0.5)
Model 76-02	.34 (0.6)	.4 (0.7)	.5 (0.8)	.6 (1.0)	.7 (1.2)
Model 76-10	1.7 (2.9)	2.1 (3.6)	2.5 (4.2)	3 (5.1)	3.3 (5.6)
Model 76-20	3.4 (5.8)	4.2 (7.1)	5 (8.5)	6 (10)	6.6 (11)
Model 76-40	6.8 (12)	8.4 (14)	10 (17)	12 (20)	14 (24)

# Compressed Air Dryers

## Membrane Air Dryers for -40°F (-40°C) Dewpoint

### Principal Specifications

Model	76-01	76-02	76-10	76-20	76-40
Nominal Flow Rate At -40°F (-40°C) Dewpoint	1 SCFM (1.7 Nm <sup>3</sup> /Hr)(1)	2 SCFM (3.4 Nm <sup>3</sup> /Hr)(1)	10 SCFM (1.7 Nm <sup>3</sup> /Hr)(1)	20 SCFM (3.4 Nm <sup>3</sup> /Hr)(1)	40 SCFM (6.8 Nm <sup>3</sup> /Hr)(1)
Min/Max Inlet Air Temp.	40°F/120°F (4°C/49°C) (2)	—————▶			
Ambient Temp. Range	40°F - 120°F (4°C - 49°C)	—————▶			
Min/Max Inlet Pressure	60 psig (4.1 barg)/150 psig (10.3 barg)	—————▶			
Compressed Air Requirement	Total Air Consumption: Regeneration Flow + Outlet Flow Requirements (see tables on pg.166)				
Max. Pressure Drop	5 psid (.34 barg) (3)	5 psid (.34 barg) (3)	5 psid (.34 barg) (3)	5 psid (.34 barg) (3)	5 psid (.34 barg) (3)
Wall Mountable	Yes	Yes	Yes	Yes	Yes
Prefilter (included)	Yes (4)	Yes (4)	Yes (4)	Yes (4)	Yes (4)
Inlet/Outlet Port Size	1/4" NPT (female)	1/4" NPT (female)	1/2" NPT (female)	1" NPT (female)	1 1/2" NPT (female)/ 3/4" NPT (female)
Electrical Requirements	None	None	None	None	None
Dimensions	6"W x 22"H x 5"D (15cm x 58cm x 13cm)	6"W x 23"H x 5"D (15cm x 58cm x 13cm)	6"W x 37"H x 5"D (15cm x 94cm x 13cm)	12"W x 37"H x 7"D (30cm x 94cm x 18cm)	19"W x 39"H x 8"D (48cm x 99cm x 21cm)
Shipping Weight	9 lbs. (4 kg)	10 lbs. (5 kg)	18 lbs. (9 kg)	20 lbs. (9 kg)	35 lbs. (16 kg)

**Notes:**

1 Dewpoint specified for saturated inlet air at 100°F (38°C) and 100 psig (6.9 barg). Outlet flows will vary slightly for other inlet conditions.

2 Inlet compressed air dewpoint must not exceed the ambient air temperature.

3 5 psid (.34 barg) at -40°F (-40°C) dewpoint operating parameters.

4 If compressed air is extremely contaminated, a Balston Grade DX prefilter should be installed directly upstream from the membrane dryer.

5 Filtration efficiency: 99.99% at 0.01 micron.

### Ordering Information

For Assistance, call toll-free at 1-800-343-4048 8AM to 5PM Eastern Time

Description	Model Number				
Balston Membrane Air Dryer	76-01	76-02	76-10	76-20	76-40
Replacement Prefilter Cartridges	100-12-BX	100-12-BX	100-18-BX	150-19-BX	200-35-BX
Optional Additional Coalescing Prefilter	2002N-1B1-DX	2002N-1B1-DX	2104N-1B1-DX	2208N-1B1-DX	2312N-1B1-DX
Replacement Filter Cartridges for Optional Prefilter	100-12-DX	100-12-DX	100-18-DX	150-19-DX	200-35-DX
Pressure Regulator (0-130 psig) 1/2" NPT Ports	72-130	72-130	72-130	-----	---

# Compressed Air Dryers

## IT Series Membrane Air Dryers for +35°F (2°C) Dewpoint\*

Offer a reliable, efficient, and economical alternative to pressure swing and refrigerant dryer technologies

Require no electricity thus lowering operating costs

Produce +35°F (2°C) pressure dewpoint, ideal for critical points of use

Produce +15°F (-9°C) dewpoint in air systems with existing refrigerated air dryers

No moving parts

Silent operation

No desiccant to change



### Applications

Food processing and automation

Electronics/Dry Boxes

Coordinate Measurement Machines

Critical Pneumatic Valves

Protection of Pneumatic Instrumentation

Low Dewpoint Instrument Air

Pneumatic Equipment

Dry Air for Hazardous Areas

### IT Series Membrane Dryers

There are many variables that will affect the output specification of compressed air. By the time air reaches all its intended point of use, changes in pressure and temperature can contribute to potential contamination. As capital equipment tolerances become tighter and more sensitive to this contamination, maintenance costs will escalate if equipment is not adequately protected. In cases where standard air filtration is not sufficient or where the reliability, performance and operating cost of older dryer technologies is becoming more significant, a Balston Membrane Dryer provides a reliable and economical alternative.

### IT Series Point of Use Membrane Dryers

Balston Membrane Air Dryers combine superior coalescing filtration technology with a proven, innovative membrane system to supply clean, dry, +35°F (2°C) pressure dewpoint compressed air. If the house compressed air is equipped with a refrigerated dryer, the dewpoint drops to +15°F (-9°C). The Balston Membrane Dryers are available in 8 different models which can deliver compressed air at flow rates up to 100 SCFM (170 NM<sup>3</sup>/Hr) .dewpoint. The systems are engineered for easy installation, operation, and long term reliability. By incorporating high efficiency coalescing filtration and the highest efficiency membrane available, the systems provide low cost operation with the lowest minimal maintenance.

\* If the house compressed air is equipped with a refrigerated dryer, the dewpoint drops to +15°F (-9°C).



# Compressed Air Dryers

## IT Series Membrane Air Dryers for +35°F (2°C) Dewpoint\*

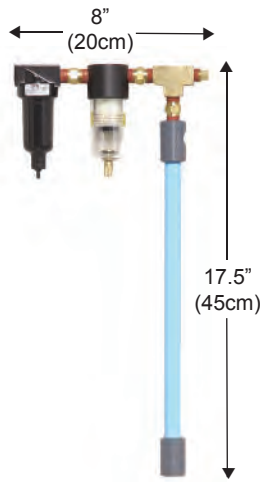

IT0010-35



IT0030-35



IT0080-35



IT0150-35



IT0250-35XX



IT0500-35XX

### Easy to Operate and Maintain

Installation consists of simply connecting a standard compressed air line to the inlet and connecting the outlet to your application. The unit is ready for trouble-free operation. This system is designed to operate 24 hours per day, 7 days per week.

Once the system is operating, it requires little monitoring. The only maintenance involves changing the coalescing prefilter cartridges periodically. The membrane module does not require any maintenance.

### Flow Rates

Model Number	IT0010-35	IT0030-35	IT0080-35	IT0150-35	IT0250-3560	IT0250-3500	IT0500-3560	IT0500-3500	IT1000-3560	IT1000-3500
Flow @ 100 psig Inlet Pressure, scfm (Nm <sup>3</sup> /Hr)	1 (1.7)	3 (5.1)	8 (13.6)	15 (25.5)	25 (42.5)	N/A	50 (85)	N/A	100 (170)	N/A
Flow @ 101-150 psig Inlet Pressure, scfm (Nm <sup>3</sup> /Hr)	1 (1.7)	3 (5.1)	8 (13.6)	15 (25.5)	N/A	25 (42.5)	N/A	50 (85)	N/A	100 (170)
Regeneration Flow @ 100 psig, scfm (Nm <sup>3</sup> /Hr) (1)	0.25 (.42)	0.5 (.85)	1.5 (2.5)	2.7 (4.6)	4.5 (7.6)	4.5 (7.6)	9.0 (15.3)	9.0 (15.3)	18.0 (30.6)	18.0 (30.6)

(1) Total Air Consumption = Regeneration + Outlet Flow.

\* If the house compressed air is equipped with a refrigerated dryer, the outlet dewpoint drops to +15°F (-9°C).

# Compressed Air Dryers

## IT Series Membrane Air Dryers for +35°F (2°C) Pressure Dewpoint\*

### Principal Specifications

Model Number	IT0010-35	IT0030-35	IT0080-35	IT0150-35	IT0250-3560	IT0250-3500	IT0500-3560	IT0500-3500	IT1000-3560	IT1000-3500
Min/Max Inlet Air Temp.	40°F/120°F (4°C/49°C)	40°F/120°F (4°C/49°C)	40°F/120°F (4°C/49°C)	40°F/120°F (4°C/49°C)	40°F/120°F (4°C/49°C)	40°F/120°F (4°C/49°C)	40°F/120°F (4°C/49°C)	40°F/120°F (4°C/49°C)	40°F/120°F (4°C/49°C)	40°F/120°F (4°C/49°C)
Min/Max Ambient Air Temp.	40°F/120°F (4°C/49°C)	40°F/120°F (4°C/49°C)	40°F/120°F (4°C/49°C)	40°F/120°F (4°C/49°C)	40°F/120°F (4°C/49°C)	40°F/120°F (4°C/49°C)	40°F/120°F (4°C/49°C)	40°F/120°F (4°C/49°C)	40°F/120°F (4°C/49°C)	40°F/120°F (4°C/49°C)
Min/Max Inlet Pressure	60/150 psig (4.1/10 barg)	60/150 psig (4.1/10 barg)	60/150 psig (4.1/10 barg)	60/150 psig (4.1/10 barg)	60/100 psig (4.1/6.9 barg)	100/150 psig (6.9/10 barg)	60/100 psig (4.1/6.9 barg)	100/150 psig (6.9/10 barg)	100/150 psig (6.9/10 barg)	100/150 psig (6.9/10 barg)
Max. Pressure Drop (1)	3 psid (.2 bard)	3 psid (.2 bard)	3 psid (.2 bard)	3 psid (.2 bard)	5 psid (.34 bard)	5 psid (.34 bard)	5 psid (.34 bard)	5 psid (.34 bard)	5 psid (.34 bard)	5 psid (.34 bard)
Wall Mountable	Yes	Yes	Yes	Yes	Yes	Yes	Yes	Yes	Yes	Yes
Mechanical Separator (Included)	F14F17B	F06F18B	F06F18B	F07F38B	F07F38B	F07F38B	F07F38B	F07F38B	F062-08WJR	F602-08WJR
Coalescing Prefilters (1)	8A02N-OB2-BX	2002N-OB1-BX	2002N-OB1-BX	2004N-1B1-DX 2004N-OB1-BX	2104N-1B1-DX 2104N-OB1-BX	2104N-1B1-DX 2104N-OB1-BX	2208N-1B1-DX 2208N-OB1-BX	2208N-1B1-DX 2208N-OB1-BX	2208N-1B1-DX 2208N-OB1-BX	2208N-1B1-DX 2208N-OB1-BX
inlet Port Size	1/4" NPT	1/4" NPT	1/4" NPT	1/2" NPT	1/2" NPT	1/2" NPT	1/2" NPT	1/2" NPT	1" NPT	1" NPT
Outlet Port Size	1/4" NPT	1/4" NPT	1/4" NPT	1/2" NPT	1" NPT	1" NPT	1" NPT	1" NPT	1" NPT	1" NPT
Electrical Requirements	None	None	None	None	None	None	None	None	None	None
Dimensions (cm)	17.5"Lx8"Wx2.5"D (44.5 x 20.3 x 6.3)	18.1"Lx10"Wx4"D (45.2 x 10.5 x 6.3)	24"Lx11.1"Wx4"D (61 x 28.2 x 6.3)	25"Lx16"Wx4.5"D (63.5 x 40.6 x 11.4)	26"Lx18"Wx6"D (66 x 45.7 x 15.2)	26"Lx18"Wx6"D (66 x 45.7 x 15.2)	39"Lx21"Wx6"D (99 x 53.3 x 15.2)	39"Dx21"Wx6"D (99 x 53.3 x 15.2)	47"Dx28"Wx7"D (119 x 71 x 18)	47"Dx28"Wx7"D (119 x 71 x 18)
Shipping Weight	1.62 lbs (.73 kg)	6.68 lbs (3 kg)	6.68 lbs (3 kg)	14.88 lbs (6.75 kg)	24.5 lbs (11.11 kg)	24.5 lbs (11.11 kg)	36.5 lbs (16.55 kg)	36.5 lbs (16.55 kg)	52 lbs (24 kg)	52 lbs (24 kg)

Notes:

1 If compressed air is extremely contaminated, a Grade DX prefilter should be installed directly upstream of the membrane dryer.

2 Filtration efficiency: 99.99% at 0.01 micron.

### Ordering Information for assistance call toll free at 800-343-4048, 8AM to 5PM EST

Model Number	IT0010-35	IT0030-35	IT0080-35	IT0150-35	IT0250-3560	IT0250-3500	IT0500-3560	IT0500-3500	IT1000-3560	IT1000-3500
Replacement Prefilter Cartridges*										
Stage 1	PS403	PS702	PS702	PS802	PS802	PS802	PS802	PS802	EK602VB	EK602VB
Stage 2	---	---	---	5/100-12-DX	5/100-18-DX	5/100-18-DX	5/100-19-DX	5/150-19-DX	5/150-19-DX	5/150-19-DX
Stage 3	5/050-05-BX	5/100-12-BX	5/100-12-BX	5/100-12-BX	5/100-18-BX	5/100-18-BX	5/150-19-BX	5/150-19-BX	5/150-19-BX	5/150-19-BX

\* If the house compressed air is equipped with a refrigerated dryer, the dewpoint drops to +15°F (-9°C).

# Compressed Air Dryers

## Membrane Air Dryers for Coordinate Measurement Machines

### The Only Way To Remove Oil and Dry Compressed Air!

Now there is only one sensible way to remove oil and dry compressed air! Refrigerant air dryers are becoming a thing of the past. High efficiency, durable membrane technology is quickly becoming the standard for drying compressed air. Parker Hannifin is leading the way with membrane technology that consumes the least amount of compressed air for regeneration.

Balston CMM Air Dryers combine a superior coalescing technology with a proven, innovative membrane system to supply clean, dry compressed air with a constant dewpoint to 35°F (2°C). The Balston CMM Air Dryers are available in 2 different models which can deliver dry, compressed air at flow rates up to 15 SCFM (25.5 Nm<sup>3</sup>/Hr). The Balston Dryers are engineered for easy installation, operation, and long term reliability.



### Customer Testimonial:

“Before we bought a Balston Membrane Dryer, we required two repairs to our CMM; the first cost \$10,000 and the next was over \$6,000. In the more than two years since installing the Balston Membrane Dryer we have not needed any repairs.”

Rick Nisula  
Maintenance Buyer  
Smith's Aerospace

### Product Features:

- **Designed specifically for use with CMMs**
- **Protects CMMs from costly repairs caused by oil and water**
- **Ideal for supplying pure, dry air to Brown & Sharpe, Zeiss, IMS and MTI CMMs**
- **No heat or vibration generated; prevents inaccurate measurements**
- **Guaranteed pressure dewpoint of 35°F (2°C)**
- **Requires no electricity resulting in lower operating costs**
- **Complete system with high efficiency coalescing filters**
- **Silent operation**
- **Minimal maintenance required**

# Compressed Air Dryers

## Membrane Air Dryers for Coordinate Measurement Machines

### Problems that cause costly repairs to Coordinate Measurement Machines:

A CMM has 26 highly sensitive air bearings per machine. If oil and moisture are present in the air system supplying the air bearings, the .5mm hole in the bottom of the air bearing will become clogged producing a "drag" in the machine. As the resistance builds, it causes hysteresis in the measurements producing an inaccurate measurement.

If this problem is allowed to continue, the bearing will drag on the aluminum ways and wear a groove in the machine. Once a groove develops, the air bearing will not produce lift if air is leaking out through the groove in the machine ways. To correct the problem, a complete rebuild of the machine at the factory is necessary which can be as costly as purchasing a new machine.

If the problem is caught in time, a service team will be required to come to the facility to repair the machine. The team will remove the bearings and the holes and grooves are cleaned with alcohol. Each bearing is then resurfaced with 600-1500 grit paper. Badly corroded or pitted air bearings are replaced at a cost of \$200.00 per bearing. Air hoses are also replaced, and all air passages are cleaned. The machine is then reassembled, and the time-consuming and costly task of recalibrating the machine with the ball bar and a B89 test is performed as the final step in repairing the machine.

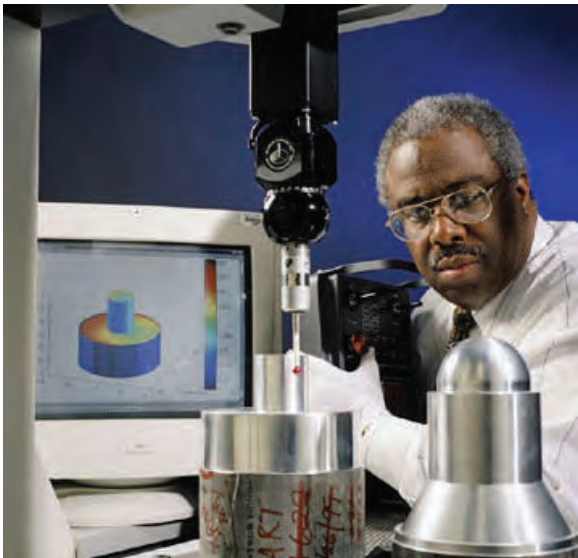

### How to avoid costly maintenance problems:

Many repairs average upwards of \$5,000.00. These costly repairs and downtime can easily be avoided by installing a Balston high efficiency Membrane Air Dryer. The Balston Membrane Air Dryer will provide extremely clean, dry air to a CMM, eliminating the possibility of contamination. The Dryer utilizes patented membrane technology, unsurpassed in performance and durability to dehydrate and purify the compressed air. The Balston Membrane Dryer is the only system designed specifically for CMM applications.

### Principal Specifications

Model Number	CM0080-35	CM0150-35
Flow @ 100 psig Inlet Pressure	8 scfm (13.6 Nm <sup>3</sup> /Hr)	15 scfm (25.5 Nm <sup>3</sup> /Hr)
Compressed Air Requirements	9.5 scfm (16.1 Nm <sup>3</sup> /Hr)	17.7 scfm (30 Nm <sup>3</sup> /Hr)
Min/Max Inlet Air Temp.	40°F/120°F (4°C/49°C)	40°F/120°F (4°C/49°C)
Min/Max Ambient Air Temp.	40°F/120°F (4°C/49°C)	40°F/120°F (4°C/49°C)
Min/Max Inlet Pressure	60/150 psig (4.1/10 barg)	60/150 psig (4.1/10 barg)
Max. Pressure Drop	3 psid (.2 bard)	3 psid (.2 bard)
Wall Mountable	Yes	Yes
Mechanical Separator Included	F06F18B	F07F38B
Coalescing Prefilters	— 8002N-0A1-BX	8004N-1A1-DX 8004N-0A1-BX
inlet Port Size	1/4" NPT	1/2" NPT
Outlet Port Size	1/4" NPT	1/2" NPT
Electrical Requirements	None	None
Dimensions (cm)	24"L x 11.1"W x 4"D (61cm x 28.2cm x 6.3cm)	25"L x 16"W x 4.5"D (63.5cm x 40.6cm x 11.4cm)
Shipping Weight	6.68 lbs (3 kg)	14.88 lbs (6.75 kg)

#### Notes:

- 1 Dewpoint specified for saturated inlet air at 100°F (38°C) and 100 psig. 35°F (2°C) Pressure Dewpoint
- 2 Filtration efficiency: 99.99% at 0.01 micron.

### Ordering Information

For assistance call toll free at 800-343-4048, 8AM to 5PM EST

Model Number	CM0080-35	CM0150-35
Replacement Filter Elements		
1st Stage	PS702	PS802
2nd Stage	100-12-BX	100-12-DX
3rd Stage	---	100-12-BX

# Compressed Air Dryers

## 5000 Series Smart Dryer Membrane Air Dryers

**Operating costs are 35 - 40% less than a refrigerant air dryer\***

**No electricity required**

**State-of-the-art membrane technology**

**Guaranteed 35°F (2°C) pressure dewpoint - 13% dryer than refrigerant dryers**

**Guaranteed 15°F (-9°C) in air systems equipped with a refrigerant air dryer**

**Durable - will hold up to the dirtiest compressed air system**

**No requirement for costly maintenance contracts**

**Output capacities to 200 scfm (340Nm<sup>3</sup>/Hr) \*\***

**Complete system with prefilters, autodrains, and pressure indicators**

**The Only Way To Dry Compressed Air!**

Now, there is only one sensible way to dry compressed air! High efficiency, durable membrane technology is quickly becoming the standard for drying compressed air. Parker Hannifin is leading the way with membrane technology that consumes the least amount of compressed air for drying.

The SMART Dryer™ utilizes sophisticated technology to monitor system parameters and automatically adjusts the regenerative sweep flow as required. The variable sweep system results in significant energy savings and low operating costs.

The SMART Dryer™ technology offers another advantage over refrigerant air drying technology as it does not produce condensate. An average 25 HP compressor system can produce up to 1,800 gallons (6.8 m<sup>3</sup>) of oily condensate per year! The refrigerant dryer condenses it into an oily/water emulsion which has to be disposed of at a high cost to you! The Balston® Membrane Air Dryer is designed to operate continuously, 24 hours a day, 7 days a week. The only maintenance required is changing the prefilter cartridges twice a year, which take approximately 5 minutes and requires no tools!

\*Non-cycling refrigerant air dryer

\*\* Consult Factory for higher flow rates



Model SMRT 5100

Applications	Benefits
<b>General Compressed Air Mainlines</b>	<b>Easy to install - no electrician required to install or maintain system</b>
<b>Process Controls</b>	
<b>HVAC Systems</b>	
<b>Instrument Cabinets</b>	
<b>CNC/CMM Machinery</b>	
<b>Fire and Sprinkler Systems</b>	
<b>Pneumatic Controls</b>	
<b>Dry Air for Hazardous Areas</b>	
<b>Chemical Blanketing and Packaging</b>	
<b>Electronics/Dry Boxes</b>	
<b>Laser Optics</b>	
<b>Spray Painting</b>	
<b>Bag House Controls</b>	
	<b>No refrigerants or freons - environmentally friendly</b>
	<b>Complete system with prefilters, auto drains, and pressure gauges</b>
	<b>Compact size</b>

# Compressed Air Dryers

## 5000 Series Smart Dryer Membrane Air Dryers

### Why buy a Balston SMART Dryer™ instead of a cycling refrigerant air dryer?

The Balston SMART Dryer will save YOU money and offer better performance!

All Balston SMART Dryers require no electricity.

All air dryers are sized based on the maximum capacity output of a compressed air system with inlet conditions assumed to be 100°F (38°C) inlet temperature, 100 psig (7 barg) inlet pressure and 100°F (38°C) ambient temperature. In the majority of installations, it is unlikely air dryers will be required to operate under these extreme conditions. Most importantly, the majority of compressed air systems are not operating at the maximum output capacity.

Refrigerant and desiccant air dryers, sized to meet these operating conditions are designed to run continuously regardless of the system's demands, when in fact the actual system conditions are far less.

The result is significant operating costs in wasted energy and wear and tear on refrigerant compressors, cooling systems, drains and other componentry.

In a typical manufacturing plant operating one 8 hour shift with a 100 SCFM (170 Nm<sup>3</sup>/Hr) compressor system running at 75% capacity (on average over the 8 hour shift), a typical non-cycling refrigerant air dryer would cost \$716 in just electrical costs alone, compared to the Balston SMART Dryer with only \$436 in electrical costs. If you factor in the annual maintenance costs of \$600 for a non-cycling refrigerant dryer compared to \$130 for the Balston SMART Dryer, there is a total annual savings of over \$750.

Recently, refrigerant manufacturers have responded to this issue by developing a cycling air dryer which cools a cold storage heat sink reservoir. Once the reservoir is cooled to the minimum temperature the compressor (refrigerant) is shut off. The compressor cycles back on when the temperature of the storage reservoir reaches a preset upper limit. This reduces the total energy consumption of the dryer however it could produce significant variations in output dewpoints.

The Balston SMART Dryer does not require refrigerant, compressors, cooling systems or other componentry that carries high operating costs (energy) and maintenance costs. The Balston SMART Dryer utilizes sophisticated technology to monitor the system parameters and automatically adjusts the regenerative sweep flow as required. The variable sweep system results in significant energy savings and low operating costs with no fluctuation in output dewpoints.

In a typical manufacturing plant operating an 8 hour shift with 100 SCFM (170 Nm<sup>3</sup>/Hr) compressor system

running at 75% capacity (on average over the 8 hour shift), a typical cycling refrigerant air dryer would cost \$454.00 in electrical costs alone, compared to the Balston SMART Dryer with only \$436.00 in electrical costs. If you factor in the annual maintenance cost of \$800 for a cycling refrigerant dryer compared to \$130.00 for the Balston SMART Dryer, there is a total annual savings of over \$685.00

Additionally, there are no moving parts, no freons that need recharging, no compressors to be serviced and no cooling coils to be cored and cleaned.

Most importantly, the Balston SMART Dryer is producing a constant 35°F dewpoint which is 13% dryer than a cycling refrigerant air dryer (ppm weight in air).

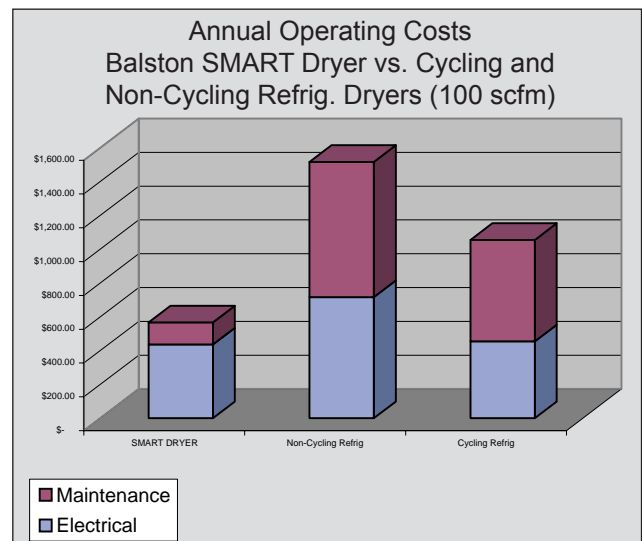

### Here's What Our Customers Say

"Our compressed air system is now completely dry and clean at a very reasonable cost. And we gain at least three hours of production time each week by not having to shut down to clean rusted valves..."

Wayne Etchells, Vice President  
Melton Corporation, Cranston, R.I.

"This new type of membrane dryer was just what we needed to eliminate problems with water building up in compressed air lines...Since the day we installed it, we haven't had a single problem with rust. The time and money we save by not having to repair spindles and air motors pays for the cost of the dryer every few months."

John Napier, Maintenance Engineer  
King Machine, Akron, OH

# Compressed Air Dryers

## 5000 Series Smart Dryer Membrane Air Dryers

Model SMRT5100  
Front View

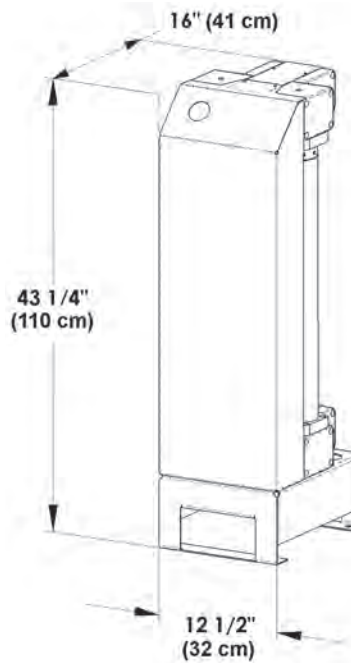

Model SMRT5200  
Front View

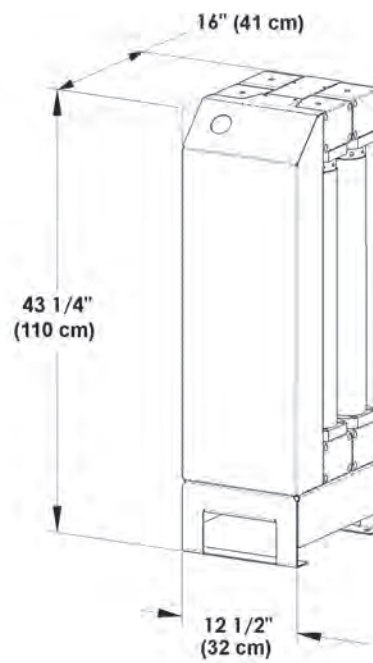

### Principal Specifications

Model Number	Membrane Air Dryers SMRT5100	SMRT5200
Max Flow Rate @35°F(2°C) dewpoint	100 SCFM (170 Nm <sup>3</sup> /Hr)	200 SCFM (340 Nm <sup>3</sup> /Hr)
Pressure Dewpoint	35°F (2°C) / 15°F (-9°C) (1)	35°F (2°C) / 15°F (-9°C) (1)
Min/Max Inlet Air Temp.	40°F/120°F (4°C/49°C)	40°F/120°F (4°C/49°C)
Ambient Temp. Range	40°F/110°F (4°/43°C)	40°F/110°F (4°/43°C)
Min/Max Inlet Pressure	80 psig/150 psig (5.5 barg/10 barg)	80 psig/150 psig (5.5 barg/10 barg)
Max Input Dewpoint	120°F (49°F)	120°F (49°F)
Max Compressed Air Requirement	113 SCFM (192 Nm <sup>3</sup> /Hr)	226 SCFM (384 Nm <sup>3</sup> /Hr)
Max Pressure Drop	10 psid (0.7 bard) (2)	10 psid (0.7 bard) (2)
Inlet/Outlet Port Size	1 1/2"NPT(male)	2"NPT(male)
Physical Dimensions	12.5"w x 43.25"h x 16"d (3) (31.75cm x 109.9cm x 40.6cm)	12.5"w x 43.25"h x 16"d (3) (31.75cm x 109.9cm x 40.6cm)
Shipping Weight	175 lbs(86 kg)	250 lbs(113kg)

### Notes:

- 1 35°F (2°C) Pressure Dewpoint specified for saturated inlet air at 100°F(38°C) and max. flow at 100 psig (6.9 barg). 15°F (-9°C) Dewpoint specified for saturated inlet air at 50°F (10°C) and max. flow at 100 psig (6.9 barg).
- 2 Max. pressure drop measured at max flow rate @ 100 psig (6.9 barg). Pressure drop will increase at lower feed pressures - consult factory.
- 3 Excluding coalescing prefilter assembly.
- 4 Filtration efficiency: 99.99% at 0.01 micron.

### Ordering Information For assistance call 1-800-343-4048

Model Number	SMRT5100	SMRT5200
Coalescing Prefilter Assembly	2312N-1B1-DX 2312N-1B1-BX	A15/80-DX A15/80-BX
Replacement Prefilter Cartridges (every 6 months)	200-35-DX 200-35-BX	200-80-DX 200-80-BX
Membrane Replacement Module	D01-0086	D01-0086
Automatic Drain Kit	21552	21552

# Compressed Air Dryers

## Cabinet Dryers Eliminate Moisture Problems in Electrical Cabinets and Motors

### Balston CD Series Cabinet Dryers

You demand a lot from your electrical cabinets and motors. They are subject to nightly high pressure, hot wash downs and then expected to remain dry in a refrigerated area. Over time most cabinets develop moisture inside which leads to premature component failures. This interrupts production and costs you money. Expensive vortex coolers or heaters don't work. Vortex coolers use a considerable amount of air and have a high operating cost. Heaters simply raise the humidity of the air inside the cabinet and don't eliminate the moisture.

The Parker Balston Cabinet Dryer serves to reduce the humidity inside the cabinet to less than 10% RH. Any water that infiltrates the cabinet evaporates quickly. Electrical components stay clean and dry which prolongs their life.

### Avoid costly down time!

Many plants struggle with moisture problems by managing downtime emergencies. Emergencies divert limited maintenance personnel and disrupt production at the cost of thousands of dollars per hour. The Cabinet Dryer reduces these maintenance and lost production costs by 80% or more. A typical customer will see savings of \$10K - 15K per year. The Cabinet Dryer will operate continuously and reliably without operator attention thus freeing up valuable maintenance personnel who are better devoted to important routine maintenance work rather than daily emergency response.

### Product Features:

- Designed specifically for wash down areas
- Protects electrical cabinet components from damage caused by water and high humidity
- Minimizes pools of water inside cabinets
- Positive pressure keeps dust out
- Adds no heat to the cabinet
- Reduces cabinet humidity to less than 10% RH
- Requires no electricity, low operating costs
- Easy to install and maintain
- Quiet operation
- Protect motors, touch screens, drives and other critical components



### Do Your Cabinets Look Like This?



Corrosion leads to premature component failure



Water accumulation in electrical cabinet

**A Cabinet Dryer will keep your cabinets looking as good as new**

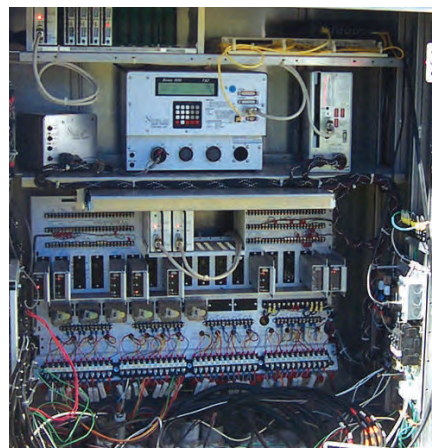



# Compressed Air Dryers

## Cabinet Dryers Eliminate Moisture Problems in Electrical Cabinets and Motors

### Principal Specifications

Model Number	CD0005	CD0010	CD0030
Cabinet Size Range (2)	0 - 4 FT <sup>3</sup> (0 - 0.11m <sup>3</sup> )	4 - 12 FT <sup>3</sup> (0.11m <sup>3</sup> - 0.34m <sup>3</sup> )	12 - 36 FT <sup>3</sup> (0.34m <sup>3</sup> - 1m <sup>3</sup> )
Min/Max Inlet Air Temp	40°F/120°F (4°C/49°C)	40°F/120°F (4°C/49°C)	40°F/120°F (4°C/49°C)
Min/Max Ambient Air Temp	35°F/120°F (2°C/49°C)	35°F/120°F (2°C/49°C)	35°F/120°F (2°C/49°C)
Air Consumption	0.6 SCFM (17 slpm)	1.25 SCFM (35.4 slpm)	3.5 SCFM (99 slpm)
Min/Max Air Pressure	60 psi/150 psi (4.1 BAR/10.3 BAR)	60 psi/150 psi (4.1 BAR/10.3 BAR)	60 psi/150 psi (4.1 BAR/10.3 BAR)
Delivered Dew Point	-7°F(-22°C) (1)	-7°F(-22°C) (1)	-7°F(-22°C) (1)
Inlet and Outlet Port Size	1/4" NPT	1/4" NPT	1/4" NPT
Electrical Requirements	None	None	None
Dimensions	3"w x 9.2"h x 2"d (7.6cm x 2.34cm x 5cm)	3"w x 15.2"h x 2"d (7.6cm x 38.6cm x 5cm)	4.6"w x 15.3"h x 2.9"d (11.7cm x 38.9cm x 7.4cm)
Shipping Weight	1.5 lbs (0.68 kg)	2 lbs (0.9 kg)	2.5 lbs (1.1 kg)

#### Notes:

- 1 Delivered dewpoint is specified for saturated inlet air at 100°F (38°C) and 100 psig (6.9 BAR).
- 2 If the cabinet is not tightly sealed, consider upsizing to the next module size.
- 3 Filtration efficiency: 99.99% at 0.01micron.
- 4 For heavily contaminated air lines, install additional prefiltration.



### Ordering Information

For assistance call toll free at 800-343-4048, 8AM to 5PM EST

Model Number	CD0005	CD0010	CD0030
Replacement Filter Elements	070-063-BX	070-063-BX	070-063-BX
Replacement Auto Drain	C02-2392	C02-2392	C02-2392

### Here's what our customers say:

"We tried heaters, fans and vortex coolers, our only solution was to use a Parker Balston dryer that continuously purges the cabinet with dry air."

- Lee Clarkson  
Ross Industries

"I've been with Smithfield for 15 years and we've had issues with wet electrical cabinets for 15 years. We installed the cabinet dryer on our wettest cabinet to see if it would work. Our Multivac™ packager was having significant issues. It was out of service 2-3 times per week due to condensation inside the cabinet. When we installed the dryer we noticed a difference right away. The water droplets on the walls of the cabinet were gone and our downtime from moisture was completely eliminated. It worked just like they told me."

Maintenance Manager  
Large Meat Processing Plant

### Principle of Operation

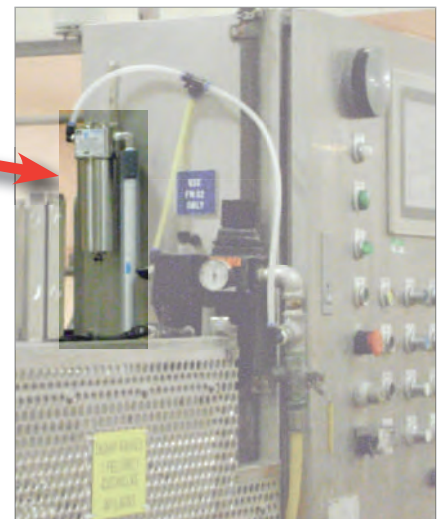
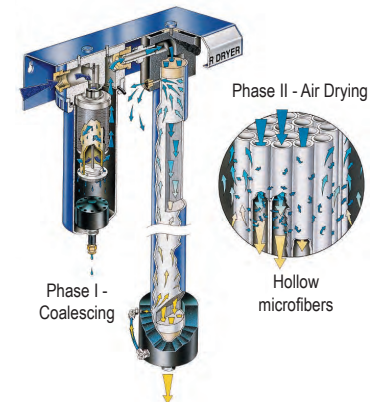

Compressed Air Dryers



# Compressed Air Dryers

## PSA Air Dryer



Balston  
Compressed Air  
Dryer

**Reduce the dewpoint of compressed air to -100°F (-73°C)**

**Unattended 24 hour operation**

**Lightweight and compact**

**No desiccant to change**

### Applications

Pneumatic Tool Stations  
HVAC Systems  
Purge Electrical Boxes  
Air Lines Subject to Sub-Freezing Temperatures  
Blanketing Moisture Sensitive Materials  
Spray Painting  
Pneumatic Instrumentation  
Robotics  
Lasers  
Dry Boxes

### Model 75-A20

Balston regenerative PSA desiccant dryer reduces the atmospheric dewpoint of compressed air without operator attention. Model 75-A20 will reduce the dewpoint to -100°F (-73°C). The dryer is delivered complete and ready for easy installation. The dryer has coalescing prefilters with automatic drains, PSA drying towers, a particulate final filter, a moisture indicator, differential pressure indicator, and pretested controls.

The Balston regenerative dryer has safe, 12 VDC electrical controls. To install, simply attach the inlet (60 psig/4.1 BARG minimum) and outlet air lines, plug the electrical transformer into a wall outlet - no electrician required - and the unit is ready for trouble-free operation.

This reliable dryer can be easily installed, operated, and maintained by personnel not trained in instrumentation. The Balston dryer is useful when air comes into contact with moisture-sensitive materials, or when outside compressed air lines are subjected to sub-freezing temperatures.

The 75-A20 is a wall mountable unit. It has a 10 SCFM(17 Nm<sup>3</sup>/hr)/min. (283 lpm) capacity (at 100 psig/6.9 BARG inlet pressure).

# Compressed Air Dryers

## PSA Air Dryer

### Principal Specifications

Model	75-A20
Dewpoint	-100°F (-73°C) (1)
Max. Dry (outlet) Air Flow Rate for Specified Dew Point (1)	
Inlet Pressure 125 psig	12.0 SCFM (340 lpm) (20 Nm <sup>3</sup> /hr)
Inlet Pressure 100 psig	10.0 SCFM (283 lpm) (17 Nm <sup>3</sup> /hr)
Inlet Pressure 80 psig	8.3 SCFM (235 lpm) (14 Nm <sup>3</sup> /hr)
Inlet Pressure 60 psig	6.5 SCFM (184 lpm) (11 Nm <sup>3</sup> /hr)
Air Loss for Regeneration	2.5 SCFM (71 lpm) (2) (4.2 Nm <sup>3</sup> /hr)
Min/Max Inlet Air Pressure	60 psig/125 psig (4.1 BARG/8.6 BARG)
Max. Inlet Air Temperature	78°F (25°C) (3)
Pressure Drop at Max. Flow Rate	8 psid (0.055 BARD)
Inlet/Outlet Port Size (female)	1/4" NPT
Electrical Requirements	120 VAC/60 Hz. (4)
Shipping Weight	50 lbs. (23 kg)
Dimensions	15"W X 41"H (38cm X 104cm)

#### Notes:

1 Dewpoint will be lower than specified at lower air flow.

2 Total air required = air loss for regeneration + process demand (up to max. dry air flow rate).

3 Outlet dewpoint will increase at higher inlet compressed air temperatures.

4 Power consumption - less than 10 watts. Each dryer is shipped with a 12 VDC plug-in transformer to connect to the local electrical supply.

5 Filtration efficiency: 99.99% at 0.01 micron.

### Ordering Information

For Assistance, call toll-free at 1-800-343-4048 8AM to 5PM Eastern Time

Description	Model Number
Balston Compressed Air Dryer	75-A20
Replacement Filter Cartridges 1st stage (box of 10)	100-18-DX
Replacement Filter Cartridges 2nd stage (box of 10)	100-18-BX
Maintenance Kit, 1 year supply of filter cartridges	MK7525P

## Customer Support and Service Network for Balston® Products



### Customer Support and Assistance

Balston products are supported by a staff of 70+ highly trained sales and service specialists located throughout North America and Canada.

The Specialists are continuously trained and updated on all Balston branded products and technologies, ensuring prompt, accurate customer service.

When on-site service isn't practical, replacement items are shipped the same day you contact us directly to your facility from one of our near by Stocking Centers or directly from our Manufacturing Plant. We guarantee overnight delivery and we pay the freight!

### World Class Manufacturing

All Balston branded products are manufactured within strict guidelines of a total quality management program. Each product incorporates superior workmanship and the best quality components available ensuring long term reliability and trouble free operation. Your complete satisfaction is guaranteed.

### Technical Support Staff

If you have technical questions, special product modifications or unique applications, Balston's technical information and support staff are available to assist you with your requirements.

These highly trained application engineers are committed to ensuring your questions are answered accurately, and your special needs are attended to. In addition, they will work closely with you on new and unique applications.

This team of engineers can be contacted at 1-800-343-4048 8AM to 5PM Eastern Time.

# Index

Part Number	Page Number(s)
050-05-( )	12, 31, 89, 174, 220
050-07-( )	98
050-11	80, 81
050-11-_Q	93, 108
050-11-( )	81, 96, 98, 99, 114, 115
05R	34, 47, 48
05R113A	47, 48
05R118A	47
05R213A	47, 48
05R218A	47
070-063-( )	25, 184, 211, 227
070-063-SA	25, 184
07R	34, 51, 52
07R213A	51, 52
07R313A	51, 52
07R413A	51, 52
06E	35, 59, 60
06E12B13A	59
06E14B13A	59
06E16B13A	59
06E18B13A	59
06E22B13A	59
06E24B13A	59
06E26B13A	59
06E28B13A	59
06E32B13A	59
06E34B13A	59
06E36B13A	59
06E38B13A	59
10F	34, 39, 40
10F01E	39, 40
10F03E	39
10F05E	39
10F07E	39
10F11E	39
10F13E	39
10F15E	39
10F17E	39
100-12-404	103
100-12-BX	14, 187, 194, 197, 199, 217, 222
100-12-DH21	104
100-12-DX	14, 194, 197, 199, 217, 222
100-12-SA	25, 184, 194, 197, 207
100-12	80, 81, 103
100-12-( )	12, 25, 29, 81, 89, 96, 97, 99, 100, 102, 114, 184, 197, 201
100-185-( )	114
100-18-BX	14, 187, 194, 197, 201, 217, 229
100-18-DX	14, 187, 194, 197, 217, 229
100-18-SA	25, 184, 194, 197, 205
100-18-( )	12, 201
100-25-DH21	104

# Index

100-25-( )	81, 89, 96, 97, 99, 100, 114
105S6	82, 83, 84, 85, 98
11010	121
11015	119
11970	68, 88, 151
11971	68, 88, 151
11972	68
11977	68, 86
12E	30, 31
12E 37	30, 31
12E 47	31
14000	68, 88, 151
14001	68, 88, 151
14157	131, 141
14158	131, 141
14159	131, 141
14160	139, 141
14162	139, 141
14163	139, 141
14164	139, 141
14165	139, 141
14166	139, 141
14168	132, 141
14172	129, 135, 136, 139, 142
14173	126, 127, 131, 135, 136, 138, 139, 140, 142
14174	126, 127, 134, 135, 136, 138, 139, 140, 142
14175	126, 127, 139, 142
14177	142
14178	135, 142
14181	129, 135, 136, 139, 142
14182	129, 135, 136, 139,142
14183	131, 138, 142
14E	35, 55, 56,
14E01B13F	55, 56
14E03B13F	55
14E05B13F	55
14E07B13F	55
14E11B13F	55, 56
14E13B13F	55
14E15B13F	55
14E17B13F	55
150-12-_X	110
150-19-BX	14, 187, 194, 217, 220
150-19-DX	13, 14, 187, 194, 217, 220
150-19-( )	13, 201
150-19-SA	194, 201, 205
15/80S6	83, 84, 85, 94, 95, 161
17L	32
17L22BE	33
17L32BE	33
17L42BE	33
19158	121

# Index

19202	121
19206	121
19290	121
19291	121
2/BE100-163-30	125
2/BE100-235-30	125
2/BE200-168-371H	121
2/BE200-168-DX	27
2/BE200-248-371H	121
200-176-( )	25, 184
200-176-BX	197
200-176-DX	193
200-176-SA	25, 184, 197
2000	186
200-185-( )	25, 184
200-185-BX	197
200-185-DX	197
200-185-SA	25, 184, 197
2002	7, 8, 11, 12 199, 201,
2002N-0A0-( )	12, 196, 197
2002N-0B1-BX	220
2002N-1B1-( )	12, 201
2002N-1B1-BX	200
2002N-1B1-DX	200, 217
2002N-1B2-( )	12, 201
2003	7, 8, 11, 12, 14, 187, 194, 199, 201, 203
200-35-BX	13, 14, 187, 194, 217, 225
200-35-DX	14, 187, 194, 217, 225
200-35-SA	194, 207
200-35-( )	13, 95, 201
2003N-1B1-( )	12, 201
2003N-1B2-( )	12, 201
2003N-0A0-( )	12, 201
2004	7, 8, 11, 12, 14, 187, 194, 199, 201
2004N-0A0-( )	12, 201
2004N-0B1-BX	220
2004N-1B1-( )	12, 201, 216
2004N-1B2-( )	12, 201
200-75-R	155
200-75-SR	179
200-80-371H	121
200-80-BX	225
200-80-DX	161, 162, 163, 225
200-80-SA	207, 209
200-80-( )	13, 20, 95, 161, 201, 205
200X	11, 198
20-211	63, 161, 162, 205
20217	121
20222	119, 121
20-402	63
20-440	63, 161, 162
20-606	65, 66

# Index

20-613	65, 66
20-623	65, 66
2/100-12-( )	29
2104	7, 8, 11, 12, 199, 201
2104N-0B1-BX	220
2104N-1B1-( )	12
2104N-1B1-BX	12, 199, 200, 201, 217, 220
2104N-1B1-DX	12, 199, 200, 201, 217, 220
2104N-1B2-( )	12, 201
2104N-0A0-SA	12, 201
21552	225
2206G-1B1-( )	12
2206G-1B2-( )	12
2206G-0A0-( )	12
2206	7, 8, 12, 13, 199, 201
2206N-1B1-( )	12, 201
2206N-1B2-( )	12, 201
2206N-0A0-( )	12, 201
2208	7, 8, 12, 13, 198, 199, 201
2208G-1B1-( )	12, 201
2208G-1B2-( )	12, 201
2208G-0A0-( )	12, 201
2208N-1B1-( )	12, 201
2208N-1B1-BX	200, 201
2208N-1B1-DX	200, 201, 217, 220
2208N-1B2-( )	12, 201
2208N-0A0-( )	12, 200, 201
23R	153
2312	7, 8, 12, 13, 199, 201
2312G-1B1-( )	12, 201
2312G-1B2-( )	12, 201
2312G-0A0-( )	12, 201
2312N-1B1-( )	201
2312N-1B1-BX	200, 201, 225
2312N-1B1-DX	200, 201, 217, 225
2312N-1B2-( )	12, 201
2312N-0A0-( )	12, 200, 201
23/75R	154, 155, 156,
23/75SR	178, 179
26/35	84, 85
26/35D-3000	94, 95
26/35D-5000	94, 95
27	94, 148
27/35	74, 82, 83, 84, 85, 94, 95, 96, 100,
27/35-3000	94, 95
27/50	144, 148
27/80	82, 83, 84, 85, 94, 95
27/80-3000	94, 95
27/95	144, 148
2A-2002N-3B1	14, 186, 187
2A-2003N-3B1	14, 186, 187
2A-2004N-3B1	14, 186, 187



# Index

2A-2104N-3B1	14, 186, 187
2A-2206N-3B1	14, 186, 187
2A-2208N-3B1	14, 186, 187
2A-2312N-3B1	14, 186, 187
30	74, 77
30/12	82, 84, 85, 89
30/25	82, 84, 85, 89
3/100-12-SA	207
3/100-12-( )	201
3/100-18-( )	201
3/100-25-SA	207
31G	81, 83, 84, 85, 99
31GCFL	74
31GCFL-1/4	114
31S6	81, 83, 84, 85, 99, 173, 174, 176
31S6CFL-1/4	113, 114
3/150-19-( )	201
3/200-16-371H	121
3/200-35-SA	207
3/200-35-( )	201
3/200-35-371H	121
3/200-80-SA	207, 209
3/200-80-( )	201, 205
33G	77, 81, 83, 84, 85, 97, 100, 144, 149
33S6	74, 81, 83, 84, 85, 97, 100, 144, 149, 173, 174, 176
37	77, 175
37/12	77, 81, 82, 83, 84, 85, 96, 175, 176
37/25	81, 82, 83, 84, 85, 96, 175, 176
38	104
38/12	104
38/25	104
39	112
39-0	111, 112
39002	110, 112
39014	110, 112
39015	110, 112
39020	110, 112
39-2	111, 112
3/9955-12-371H	121
3/9956-12-371H	121
3B-2002N-3B1	193, 194
3B-2003N-3B1	193, 194
3B-2004N-3B1	193, 194
3B-2104N-3B1	193, 194
3B-2206N-3B1	193, 194
3B-2208N-3B1	193, 194
3B-2312N-3B1	193, 194
3B-6002N-0A1	196, 197
3B-6904N-0A1	196, 197
3B-6004N-0A1	196, 197
3B-6006N-0A1	196, 197
3B-6008N-0A1	196, 197

# Index

41-070	67
41-071	12, 67, 162, 205
41G	81, 83, 84, 85, 99
41GCFL	74
41GCFL-1/4	113, 114
41S6	81, 83, 84, 85, 99, 173, 174, 176
41S6CFL-1/4	114
4433-05	68, 69, 84, 85, 86, 87, 88, 92, 151
4433-05-BX	68, 69
4433-05-( )	68, 69, 88, 92, 151
45G	77, 81, 83, 84, 85, 97, 100, 144, 149
45S6	81, 83, 84, 85, 97, 100, 144, 149, 173, 174, 176
47S6	82, 83, 84, 85, 115
48S6	74, 81, 82, 83, 84, 85, 113, 114
49S6	74, 82, 83, 84, 85, 113, 114
5/050-05-( )	12, 31, 220
5/070-063-(?x)	25, 184
5/100-12-BX	14, 187, 194, 197, 220
5/100-12-DX	14, 187, 194, 197, 201, 220
5/100-12-SA	194, 197, 205
5/100-12-( )	12, 25, 184, 201
5/100-18-BX	14, 187, 194, 220
5/100-18-DX	14, 187, 194, 220
5/100-18-SA	194, 197
5/100-18-( )	12, 25, 184, 201
5/100-19-( )	220
5/130-14-( )	31
5/150-19-( )	13, 201
5/150-19-BX	14, 187, 194, 220
5/150-19-DX	13, 14, 187, 194, 220
5/150-19-SA	14, 187, 194
5/200-35-( )	13, 201
5/200-35-BX	14, 187, 194
5/200-35-DX	14, 187, 194
5/200-35-SA	194
5/200-176-( )	25, 184
5/200-176-BX	197
5/200-176-DX	197
5/200-176-SA	197
5/200-185-( )	25, 184
5/200-185-BX	197
5/200-185-DX	197
5/200-185-SA	197
5/200-80-( )	13, 20, 201, 205
510-28-HEC	18, 166
510-36-HEC	18, 166
510-28-HFC	18, 166
53	101, 146, 156
53/18	82, 83, 101, 102, 144, 146, 147
53/50	82, 83, 101, 102, 144, 146, 147, 156, 157
53/95	83, 144, 146, 147, 156, 157
54	101

# Index

54/50	83, 101, 102, 144, 146, 147
57-501	152
57-501-C	152
57-501-F	152
57-501-M	152
58N	103
58P	83, 101, 102, 144, 146, 147
6102	23, 24, 25, 182, 183, 184
6102N-0A0-( )	25, 184
6102N-0A1-( )	25, 24, 25, 184
6102N-0A2-( )	23, 24, 25, 184
6002	23, 24, 25, 182, 183, 184
6002N-0A1-( )	23, 24, 25, 184
6002N-0A2-( )	23, 24, 25, 184
6004	23, 24, 25, 182, 183, 184, 197
6004N-0A1-( )	23, 24, 25, 182, 184
6004N-0A2-( )	23, 24, 25, 184
6006	23, 24, 25, 180, 182, 183, 184
6006N-0A1-( )	23, 24, 25, 184
6006N-0A2-( )	23, 24, 25, 184
6008	23, 24, 25, 180, 182, 183, 184
6008N-0A1-( )	23, 24, 25, 184
6008N-0A2-( )	23, 24, 25, 184
6904	23, 24, 25, 182, 183, 184
6904N-0A1-( )	23, 24, 25, 184
6904N-0A2-( )	23, 24, 25, 184
7/200-35-371H	121
7/200-80-371H	121
72-130	217
75-A20	228, 229
76-01	216, 217
76-02	216, 217
76-10	216, 217
76-20	216, 217
76-40	216, 217
8002N-0A1-BX	222
8004N-0A1-BX	222
8004N-1A1-DX	222
850-25-HEC	18, 166
850-25-HFC	18, 166
850-36-HEC	18, 166
850-36-HFC	18, 166
8800-12	83, 84, 85, 86, 87, 88, 93
8800-12-( )	88, 93
8822-( )-( )	82
8822-11	68, 69, 74, 76, 82, 83
8822-11-( )	82
8833-11	68, 69, 74, 82, 83, 84, 85, 86, 87, 88, 92
8833-11-BX	68, 69
8833-11-DX	68, 69
8833-11-( )	68, 69, 86, 88, 92
85	77, 81, 82, 83, 84, 85, 96

# Index

90	76, 82, 83, 84, 85, 101, 102
91	81
91S6	77, 82, 83, 84, 85, 98, 99, 173, 174, 176
92-810	29
92-810A	29
92-812	29
92-812A	29
95	74, 81, 98
95A	82, 83, 84, 85, 98
95M	76, 82, 83, 84, 85, 98
95S6	77, 82, 83, 84, 85, 98, 173, 174, 176
95T	76, 82, 83, 84, 85, 98, 173, 174, 176
97S6	82, 84, 85, 89, 173, 174, 176
98	105, 106
98-0	105, 106
98002	106, 108
98010	108
98011	108
98012	108
98013	108
98014	106
98015	106
98020	106, 108
98-2	105, 106
9900-05	68, 69, 84, 85, 86, 87, 88, 92, 93
9900-05-BK	68, 69, 86
9900-05-( )	68, 69, 88, 92
9922-05	68, 69, 82, 83, 84, 85, 86, 87, 88, 92, 150, 151
9922-05-( )	68, 69, 82, 88, 92, 93, 151
9922-11	68, 69, 82, 83, 84, 85, 86, 87, 88, 92, 150, 151
9922-11-95	172, 176
9922-11-( )	68, 69, 82, 88, 92, 151
9933-05	68, 69, 75, 82, 83, 84, 85, 86, 87, 88, 92, 150, 151
9933-05-95	172, 176
9933-05-DQ	76
9933-05-( )	68, 69, 88, 92, 151
9933-11	68, 69, 83, 84, 85, 86, 87, 88, 92, 150, 151
9933-11-( )	68, 69, 88, 92, 151
9953-11	86, 87, 88, 93
9953-11-( )	88, 93
9955-05-DX	26, 27
9955-11-DX	26, 27
9955-12	120, 121, 126, 127, 128, 130, 131, 132, 133, 134, 136, 139, 140
9955-12-371H	120, 121
9955-12-DX	26, 27
9956-12	120, 121, 126, 127, 128, 129, 130, 132, 135, 136, 139
9956-12-371H	120, 121
A01-0459	191
A05-0045	81
A05-0046	81
A05-0097	121
A15/80	7, 8, 13, 198, 201

# Index

A15/80-BX	200, 201, 225
A15/80-DX	200, 201, 225
A15/80-SA	200, 201
A15/80S6-SA	200, 201
A27/35B	207
A27/35B-SA	200, 206, 207
A27/80B	207
A27/80B-SA	200, 206, 207
A33B	207
A33B-SA	200, 206, 207
A34	158
A39/12	109, 110
A39/12-_X-0	110
A39/12-_X-2	110
A39-0	110
A39-2	110
A45B	207
A45B-SA	200, 206, 207
A914	7, 8, 11, 12
A914A	11, 12
A914D	7, 8, 11
A914P	7, 8, 11
A94A-( )	7, 8
A98	107, 108
A98/11	108
A98/11-( )Q-( )	108
A98/11-_Q	108
A98/11-_Q-0	108
A98/11-_Q-2	108
A98/11-BQ-2	108
A98/11-DQ-2	108
AFF10-0728-HEC	17, 18, 19, 165, 166, 167, 200, 203
AFF10-0728-HFC	17, 18, 19, 165, 166, 167, 200, 203
AFF12-1128-HEC	17, 18, 19, 165, 166, 167, 203
AFF12-1128-HFC	17, 18, 19, 165, 166, 167, 203
AFF16-1528-HEC	17, 18, 19, 165, 166, 167, 203
AFF16-1528-HFC	17, 18, 19, 165, 166, 167, 203
AFF3-0128-HEC	17, 18, 19, 165, 166, 167, 200, 203
AFF3-0128-HFC	17, 18, 19, 165, 166, 167, 200, 203
AFF4-0125-HEC	17, 18, 19, 165, 166, 167, 200, 203
AFF4-0125-HFC	17, 18, 19, 165, 166, 167, 200, 203
AFF6-0136-HEC	17, 18, 19, 165, 166, 167, 200, 203
AFF6-0136-HFC	17, 18, 19, 165, 166, 167, 200, 203
AFF6-0328-HEC	17, 18, 19, 165, 166, 167, 203
AFF6-0328-HFC	17, 18, 19, 165, 166, 167, 203
AFF8-0428-HEC	17, 18, 19, 165, 166, 167, 200, 203
AFF8-0428-HFC	17, 18, 19, 165, 166, 167, 200, 203
AFN3-0128-HEC	17, 18, 19, 165, 166, 167
AFN3-0128-HFC	17, 18, 19, 165, 166, 167
AFR-940	30, 31
AFR-940-( )	31
AFR-940-130	31

# Index

AFR-940-30	31
AFR-940-60	31
AFR-940A	30, 31
AFR-940A-( )	31
AFR-940A-30	31
AFR-940A-60	31
AFR-940A-130	31
AHC-0180	161, 163
AHC-0180-( )	161
AHC-0180-DX	161
AHC-0280	161, 163
AHC-0280-( )	161
AHC-0280-DX	161
AHC-0480	161, 163
AHC-0480-( )	161
AHC-0480-DX	161
AHC-0880	162, 163
AHC-0880-( )	162
AHC-0880-DX	162
AKC-0280	200, 204, 205
AKC-0280-SA	200, 205
AKC-0480	205
AKC-0480-SA	200, 205
AKC-0880	205
AKC-0880-( )	162
AKC-0880-SA	200, 205
AKC-1480	204, 205
AKC-1480-DX	162
AKC-1480-SA	200, 205
AKC-2280	200, 205
AKC-2280-DX	162
AKC-2280-SA	200, 205
AKH-0280	7, 8, 20, 160, 161, 163
AKH-0280-( )	20, 161
AKH-0280-DX	161
AKH-0480	7, 8, 20, 161, 163
AKH-0480-( )	20, 161
AKH-0480-DX	161
AKH-0880	7, 8, 20, 160, 162, 163
AKH-0880-( )	20, 162
AKH-0880-DX	162
AKH-1480	3, 4, 20, 162, 163
AKH-1480-( )	20, 162
AKH-1480-DX	20, 162
AKH-2280	7, 8, 20, 162, 163
AKH-2280-( )	20, 162
AKS-0280	161, 163
AKS-0280-DX	161, 163
AKS-0480	161, 163
AKS-0480-DX	161, 163
AKS-0880	162, 163
AKS-0880-( )	162, 163

# Index

AKS-1480	162, 163
AKS-1480-( )	162, 163
AKS-2280	162, 163
AKS-2280-( )	162, 163
AKSB-0280-2	209
AKSB-0280-2-SA	209
AKSB-0280-3	209
AKSB-0280-3-SA	208, 206
AKSB-0280-SA	200, 209
AKSB-0480	209
AKSB-0480-SA	200, 209
AKSB-0880	209
AKSB-0880-SA	200, 209
AKSB-1480	209
AKSB-1480-SA	200, 208, 209
AKSB-2280	209
AKSB-2280-SA	200, 209
ALF3-0128-HEC	17, 18, 19, 165, 166, 167
ALF3-0128-HFC	17, 18, 19, 165, 166, 167
ALF4-0125-HEC	17, 18, 19, 165, 166, 167
ALF4-0125-HFC	17, 18, 19, 165, 166, 167
ALF6-0136-HEC	17, 18, 19, 165, 166, 167
ALF6-0136-HFC	17, 18, 19, 165, 166, 167
ALF6-0328-HEC	17, 18, 19, 165, 166, 167
ALF6-0336-HFC	17, 18, 165, 166
ALN3-0128-HEC	17, 18, 19, 165, 166, 167
ALN3-0128-HFC	17, 18, 19, 165, 166, 167
AR-009	120, 126
AR-009-DX	26, 27
AR-009-371H	120, 121
AR-015	126
AR-015-371H	120, 121
AR-0316	120, 121, 126, 127, 128, 129, 130, 131, 132, 133, 134, 135, 136, 138, 139, 140
AR-0316-371H	120, 121
AR-0335	120, 121, 126, 127, 128, 129, 130, 131, 132, 133, 134, 135, 136, 137, 138, 140
AR-0335-371H	120, 121
AR-0735	120, 121, 126, 127, 128, 129, 130, 131, 132, 133, 134, 135, 136, 137, 138, 139, 140
AR-0735-371H	120, 121
AR-0780	120, 121, 126, 127, 128, 129, 130, 131, 132, 133, 134, 135, 137, 138, 140
AR-0780-371H	120, 121
AR-1280	120, 121, 126, 127, 128, 129, 130, 133, 134, 135, 137, 138, 140
AR-1280-371H	120, 121
AR-1680	120, 121, 126, 127, 128, 129, 133, 134, 135, 137, 138
AR-1680-371H	120, 121
AR-3080	120, 121, 127, 128, 129, 133, 134, 135, 137, 138, 139, 140
AR-3080-371H	120, 121
BE100-163-30	125
BE100-235-30	125
BE200-168-371H	121
BE200-168-DX	27
BE200-248-371H	121
C01-0094	25, 184, 197

# Index

C01-0108	25, 184
C01-0109	25, 184
C01-0122	191
C01-0123	191
C01-0124	191
C01-0125	191
C01-0126	191
C01-0127	191
C02-2377	67
C02-2392	25, 184, 211, 227
C02-2418	191
C10A1308	54
CD0005	211, 227
CD0010	211, 227
CD0030	211, 227
CF-0112	122, 123
CF-0112-102	123
CF-0112-30	123
CF-0118	122, 123
CF-0118-102	123
CF-0118-30	122, 123
CI-100-12-000	6, 12, 22, 25, 181, 184
CI-100-18-000	25, 184
CI-100-25-000	12
CI150-19-000	13
CI200-35-000	13
CI200-80-000	13, 20
CI-200-176-000	25, 184
CI-200-185-000	25, 184
CI-200-35-000	95, 96, 100,
CM0080-35	222
CM0150-35	222
CV-0112	126, 127, 128, 129, 130, 131, 132, 133, 134, 135, 136, 139, 140
CV-0112-30	124, 125
CV-0112-371H	118, 119
CV-0118	118, 119, 126, 127, 128, 129, 130, 131, 132, 133, 134, 135, 136, 137, 138, 139, 140
CV-0118-30	124, 125
CV-0118-371H	118, 119
D01-0086	225
DH21	104
EK602VB	220
ET-100-12-30	158
FB11	35, 61, 62
FB11-04DGC-SS	62
FB11-04WGCSS	61
FB11-04WGRSS	61
FB11G04WGCSS	61
FB11G04WGRSS	61
FB548	35, 57, 58
FB548-02DGCSS	57
FF10	34, 37, 38
FF10-04DGSS	37, 38



# Index

FF10-04DGRSS	37
FF10-04WGSS	37
FF10-04WGRSS	37
FF11	34, 43, 44
FF11-04DJSS	44
FF11-04DJRS	43
FF11G04WJSS	43
FF11G04WJRSS	43
FF501	34, 41, 42
FF501-02DHSS	41
FR10	34, 49, 50
FR10-04CSS	49
FR364	34, 45, 46
FR364-02CSS	45
GS-050-05-95	174
GS-050-11-95	174
GS-100-12-95	174
GS-100-25-95	174, 175
GS-3/050-05-95	174
GS-3/050-11-95	174
GS-3/100-12-95	174
GS-3/100-25-95	174
IT0010-35	219, 220
IT0030-35	219, 220
IT0080-35	219, 220
IT0150-35	219, 220
IT0250-3500	219, 220
IT0250-3560	219, 220
IT0500-3500	219, 220
IT0500-3560	219, 220
IT1000-3500	219, 220
IT1000-3560	219, 220
K4520N14060	48, 52, 54, 60
K4520N14160	48, 52, 54, 60
KS-0280-3	161
KS-0480-4	161
LP-100-12-( )	102, 144, 147, 149
LP-100-25-( )	144, 149
LP-200	101, 146, 148
LP-200-12-80	149
LP-200-18-( )	102, 144, 147
LP-200-18-80	147
LP-200-50-( )	102, 144, 147, 148
LP-200-50-20	156, 157
LP-200-50-80	148
LP-200-95-( )	144, 147, 148
LP-200-95-20	156, 157
MK7525P	229
P3NKA00MW	54
P3NKA00PN	54
P3NKA00RR	54
P3NR	34, 53, 54

# Index

P3NRA96BNN	53
P3NRA98BNN	53
P3NRA9PBNN	53
PS403	220
PS702	60, 220, 222
PS748P	33
PS802	220, 222
R-009	120, 124, 127, 128, 129, 130, 131, 132, 133, 134, 135, 136, 137, 138, 139, 140
R-009-30	124, 125
R-015	124, 125, 127, 128, 129, 130, 131, 132, 133, 134, 135, 136, 138, 139, 140
R-015-30	124, 125
SAP05481	25, 38, 42, 44, 184
SMRT5100	213, 225
SMRT5200	225
SP2-23/75SR	179
SP3-23-75SR	179
SP4-23-75SR	179
SP6-23/75SR	178, 179
SS-100-12	96, 97, 99, 100, 114
SS-100-25	96, 97, 99, 100, 114
SS-200-35	95
SS-200-80	95
WF-200-50-C	152
WF-200-50-F	152
WF-200-50-M	152
WF-3/200-50-C	152
WF-3/200-50-F	152
WF-3/200-50-M	152
WS002N	4
WS003N	4
WS004N	4
WS0H3N	4
WS0H4N	4
WS006N	4
WS008N	4
WS0H6N	4
WH0H8N	4
WS0010N	4
WS0012N	4
WS0H10N	4
WS0H12N	4
WS0016N	4
WS0020N	4
WS0024N	4

**PARKER-HANNIFIN CORPORATION – FILTRATION AND SEPARATION DIVISION**  
**OFFER OF SALE**

The goods, services or work (referred to as the "Products") offered by **Parker-Hannifin Corporation's Filtration and Separation Division**, its subsidiaries, and authorized distributors ("Seller") are offered for sale at prices indicated in the offer, or as may be established by Seller. The offer to sell the Products and acceptance of Seller's offer by any customer ("Buyer") is contingent upon, and will be governed by all of the terms and conditions contained in this Offer of Sale. Buyer's order for any Products specified in Buyer's purchase document or Seller's offer, proposal or quote ("Quote") attached to the purchase order, when communicated to Seller verbally, or in writing, shall constitute acceptance of this offer.

- 1. Terms and Conditions.** Seller's willingness to offer Products for sale or accept an order for Products is subject to the terms and conditions contained in this Offer of Sale or any newer version of the same, published by Seller electronically at [www.parker.com/saleterms/](http://www.parker.com/saleterms/). Seller objects to any contrary or additional terms or conditions of Buyer's order or any other document or other communication issued by Buyer.
- 2. Price; Payment.** Prices stated on Seller's Quote are valid for thirty (30) days, except as explicitly otherwise stated therein, and do not include any sales, use, or other taxes or duties unless specifically stated. Seller reserves the right to modify prices to adjust for any raw material price fluctuations. Unless otherwise specified by Seller, all prices are F.C.A. Seller's facility (INCOTERMS 2010). Payment is subject to credit approval and payment for all purchases is due thirty (30) days from the date of invoice (or such date as may be specified by Seller's Credit Department). Unpaid invoices beyond the specified payment date incur interest at the rate of 1.5% per month or the maximum allowable rate under applicable law.
- 3. Shipment; Delivery; Title and Risk of Loss.** All delivery dates are approximate. Seller is not responsible for damages resulting from any delay. Regardless of the manner of shipment, delivery occurs and title and risk of loss or damage pass to Buyer, upon placement of the Products with the shipment carrier at Seller's facility. Unless otherwise stated, Seller may exercise its judgment in choosing the carrier and means of delivery. No deferral of shipment at Buyers' request beyond the respective dates indicated will be made except on terms that will indemnify, defend and hold Seller harmless against all loss and additional expense. Buyer shall be responsible for any additional shipping charges incurred by Seller due to Buyer's acts or omissions.
- 4. Warranty.** Seller warrants that the Products sold hereunder shall be free from defects in material or workmanship for a period of twelve (12) months from the date of shipment and covers in-factory repair and parts only. All prices are based upon the exclusive limited warranty stated above, and upon the following disclaimer: **DISCLAIMER OF WARRANTY: THIS WARRANTY IS THE SOLE AND ENTIRE WARRANTY PERTAINING TO PRODUCTS PROVIDED. SELLER DISCLAIMS ALL OTHER WARRANTIES, EXPRESS AND IMPLIED, INCLUDING DESIGN, MERCHANTABILITY AND FITNESS FOR A PARTICULAR PURPOSE.**
- 5. Claims; Commencement of Actions.** Buyer shall promptly inspect all Products upon receipt. No claims for shortages will be allowed unless reported to the Seller within ten (10) days of delivery. No other claims against Seller will be allowed unless asserted in writing within thirty (30) days after delivery. Buyer shall notify Seller of any alleged breach of warranty within thirty (30) days after the date the defect is or should have been discovered by Buyer. Any claim or action against Seller based upon breach of contract or any other theory, including tort, negligence, or otherwise must be commenced within twelve (12) months from the date of the alleged breach or other alleged event, without regard to the date of discovery. ***If product is returned for a refund, a 20% restock fee may apply.***
- 6. LIMITATION OF LIABILITY.** IN THE EVENT OF A BREACH OF WARRANTY, SELLER WILL, AT ITS OPTION, REPAIR OR REPLACE A DEFECTIVE PRODUCT, OR REFUND THE PURCHASE PRICE WITHIN A REASONABLE PERIOD OF TIME. **IN NO EVENT IS SELLER LIABLE FOR ANY SPECIAL, INDIRECT, INCIDENTAL OR CONSEQUENTIAL DAMAGES ARISING OUT OF, OR AS THE RESULT OF, THE SALE, DELIVERY, NON-DELIVERY, SERVICING, USE OR LOSS OF USE OF THE PRODUCTS OR ANY PART THEREOF, OR FOR ANY CHARGES OR EXPENSES OF ANY NATURE INCURRED WITHOUT SELLER'S WRITTEN CONSENT, WHETHER BASED IN CONTRACT, TORT OR OTHER LEGAL THEORY. IN NO EVENT SHALL SELLER'S LIABILITY UNDER ANY CLAIM MADE BY BUYER EXCEED THE PURCHASE PRICE OF THE PRODUCTS.**
- 7. User Responsibility.** The user, through its own analysis and testing, is solely responsible for making the final selection of the system and Product and assuring that all performance, endurance, maintenance, safety and warning requirements of the application are met. The user must analyze all aspects of the application and follow applicable industry standards and Product information. If Seller provides Product or system options based upon data or specifications provided by the user, the user is responsible for determining that such data and specifications are suitable and sufficient for all applications and reasonably foreseeable uses of the Products or systems.
- 8. Loss to Buyer's Property.** Any designs, tools, patterns, materials, drawings, confidential information or equipment furnished by Buyer or any other items which become Buyer's property, will be considered obsolete and may be destroyed by Seller after two (2) consecutive years have elapsed without Buyer ordering the items manufactured using such property. Seller shall not be responsible for any loss or damage to such property while it is in Seller's possession or control.
- 9. Special Tooling.** A tooling charge may be imposed for any special tooling, including without limitation, dies, fixtures, molds and patterns, acquired to manufacture Products. Such special tooling shall be and remain Seller's property notwithstanding payment of any charges by Buyer. In no event will Buyer acquire any interest in apparatus belonging to Seller which is utilized in the manufacture of the Products, even if such apparatus has been specially converted or adapted for such manufacture and notwithstanding any charges paid by Buyer. Unless otherwise agreed, Seller has the right to alter, discard or otherwise dispose of any special tooling or other property in its sole discretion at any time.
- 10. Buyer's Obligation; Rights of Seller.** To secure payment of all sums due or otherwise, Seller retains a security interest in all Products delivered to Buyer and this agreement is deemed to be a Security Agreement under the Uniform Commercial Code. Buyer authorizes Seller as its attorney to execute and file on Buyer's behalf all documents Seller deems necessary to perfect its security interest.
- 11. Improper Use and Indemnity.** Buyer shall indemnify, defend, and hold Seller harmless from any losses, claims, liabilities, damages, lawsuits, judgments and costs (including attorney fees and defense costs), whether for personal injury, property damage, patent, trademark or copyright infringement or any other claim, brought by or incurred by Buyer, Buyer's employees, or any other person, arising out of: (a) improper selection, application, design, specification or other misuse of Products purchased by Buyer from Seller; (b) any act or omission, negligent or otherwise, of Buyer; (c) Seller's use of patterns, plans, drawings, or specifications furnished by Buyer to manufacture Products; or (d) Buyer's failure to comply with these terms and conditions. Seller shall not indemnify Buyer under any circumstance except as otherwise provided.
- 12. Cancellations and Changes.** Buyer may not cancel or modify or cancel any order for any reason, except with Seller's written consent and upon terms that will indemnify, defend and hold Seller harmless against all direct, incidental and consequential loss or damage. Seller may change Product features, specifications, designs and availability. ***Order cancellation fee of 15% may apply.***
- 13. Limitation on Assignment.** Buyer may not assign its rights or obligations under this agreement without the prior written consent of Seller.
- 14. Force Majeure.** Seller does not assume the risk and is not liable for delay or failure to perform any of Seller's obligations by reason of events or circumstances beyond its reasonable control (hereinafter "Events of Force Majeure"). Events of Force Majeure shall include without limitation: accidents, strikes or labor disputes, acts of any government or government agency, acts of nature, delays or failures in delivery from carriers or suppliers, shortages of materials, or any other cause beyond Seller's reasonable control.
- 15. Waiver and Severability.** Failure to enforce any provision of this agreement will not invalidate that provision; nor will any such failure prejudice Seller's right to enforce that provision in the future. Invalidation of any provision of this agreement by legislation or other rule of law shall not invalidate any other provision herein. The remaining provisions of this agreement will remain in full force and effect.
- 16. Termination.** Seller may terminate this agreement for any reason and at any time by giving Buyer thirty (30) days prior written notice. Seller may immediately terminate this agreement, in writing, if Buyer: (a) breaches any provision of this agreement (b) appoints a trustee, receiver or custodian for all or any part of Buyer's property (c) files a petition for relief in bankruptcy on its own behalf, or one if filed by a third party (d) makes an assignment for the benefit of creditors; or (e) dissolves its business or liquidates all or a majority of its assets.
- 17. Governing Law.** This agreement and the sale and delivery of all Products are deemed to have taken place in, and shall be governed and construed in accordance with, the laws of the State of Ohio, as applicable to contracts executed and wholly performed therein and without regard to conflicts of laws principles. Buyer irrevocably agrees and consents to the exclusive jurisdiction and venue of the courts of Cuyahoga County, Ohio with respect to any dispute, controversy or claim arising out of or relating to this agreement.
- 18. Indemnity for Infringement of Intellectual Property Rights.** Seller is not liable for infringement of any patents, trademarks, copyrights, trade dress, trade secrets or similar rights except as provided in this Section. Seller will defend and indemnify Buyer against allegations of infringement of U.S. patents, U.S. trademarks, copyrights, trade dress and trade secrets ("Intellectual Property Rights"). Seller will defend at its expense and will pay the cost of any settlement or damages awarded in an action brought against Buyer based on an allegation that a Product sold pursuant to this agreement infringes the Intellectual Property Rights of a third party. Seller's obligation to defend and indemnify Buyer is contingent on Buyer notifying Seller within ten (10) days after Buyer becomes aware of such allegations of infringement, and Seller having sole control over the defense of any allegations or actions including all negotiations for settlement or compromise. If a Product is subject to a claim that it infringes the Intellectual Property Rights of a third party, Seller may, at its sole expense and option, procure for Buyer the right to continue using the Product, replace or modify the Product so as to make it noninfringing, or offer to accept return of the Product and refund the purchase price less a reasonable allowance for depreciation. Notwithstanding the foregoing, Seller is not liable for claims of infringement based on information provided by Buyer, or directed to Products delivered hereunder for which the designs are specified in whole or part by Buyer, or infringements resulting from the modification, combination or use in a system of any Product sold hereunder. The foregoing provisions of this Section constitute Seller's sole and exclusive liability and Buyer's sole and exclusive remedy for infringement of Intellectual Property Rights.
- 19. Entire Agreement.** This agreement contains the entire agreement between the Buyer and Seller and constitutes the final, complete and exclusive expression of the terms of sale. All prior or contemporaneous written or oral agreements or negotiations with respect to the subject matter are herein merged. The terms contained herein may not be modified unless in writing and signed by an authorized representative of Seller.
- 20. Compliance with Laws.** Buyer agrees to comply with all applicable laws, regulations, and industry and professional standards of care, including those of the United Kingdom, the United States of America, and the country or countries in which Buyer may operate, including without limitation the U. K. Bribery Act, the U.S. Foreign Corrupt Practices Act ("FCPA"), the U.S. Anti-Kickback Act ("Anti-Kickback Act") and the U.S. Food Drug and Cosmetic Act ("FDCA"), each as currently amended, and the rules and regulations promulgated by the U.S. Food and Drug Administration ("FDA"), and agrees to indemnify and hold harmless Seller from the consequences of any violation of such provisions by Buyer, its employees or agents. Buyer acknowledges that it is familiar with the provisions of the U. K. Bribery Act, the FCPA, the FDA, and the Anti-Kickback Act, and certifies that Buyer will adhere to the requirements thereof. In particular, Buyer represents and agrees that Buyer will not make any payment or give anything of value, directly or indirectly to any governmental official, any foreign political party or official thereof, any candidate for foreign political office, or any commercial entity or person, for the purpose of influencing such person to purchase Products or otherwise benefit the business of Seller.

# Worldwide Filtration Manufacturing Locations

## North America

**Compressed Air Treatment  
Filtration & Separation/Balston**  
Haverhill, MA  
978 858 0505  
www.parker.com/balston

**Finite Airtek Filtration  
Airtek/dornick hunter/Zander**  
Lancaster, NY  
716 686 6400  
www.parker.com/faf

**Finite Airtek Filtration/Finite**  
Oxford, MI  
248 628 6400  
www.parker.com/finitefilter

**Engine Filtration &  
Water Purification  
Racor**  
Modesto, CA  
209 521 7860  
www.parker.com/racor

**Racor**  
Holly Springs, MS  
662 252 2656  
www.parker.com/racor

**Racor**  
Beaufort, SC  
843 846 3200  
www.parker.com/racor

**Racor – Village Marine Tec.**  
Gardena, CA  
310 516 9911  
desalination.parker.com

**Hydraulic Filtration  
Hydraulic Filter**  
Metamora, OH  
419 644 4311  
www.parker.com/hydraulicfilter

Laval, QC Canada  
450 629 9594  
www.parkerfarr.com

**Process Filtration  
dornick hunter Process Filtration**  
Oxnard, CA  
805 604 3400  
www.parker.com/processfiltration

## Europe

**Compressed Air Treatment  
dornick hunter Filtration & Separation**  
Gateshead, England  
+44 (0) 191 402 9000  
www.parker.com/dhfn

**Parker Gas Separations**  
Etten-Leur, Netherlands  
+31 76 508 5300  
www.parker.com/dhfn

**Hiross Zander**  
Padova Business Unit  
Padova, Italy  
+39 049 9712 111  
www.parker.com/hzd

**Hiross Zander**  
Essen Business Unit  
Essen, Germany  
+49 2054 9340  
www.parker.com/hzd

**Engine Filtration &  
Water Purification  
Racor**  
Dewsbury, England  
+44 (0) 1924 487 000  
www.parker.com/ffde

**Racor Research & Development**  
Stuttgart, Germany  
+49 (0)711 7071 290-10  
www.parker.com/ffde

**Hydraulic Filtration  
Hydraulic Filter**  
Arnhem, Holland  
+31 26 3760376  
www.parker.com/hfde

**Urjala Operation**  
Urjala, Finland  
+358 20 753 2500  
www.parker.com/hfde

**Condition Monitoring Center**  
Norfolk, England  
+44 1842 763 299  
www.parker.com/hfde

**Process Filtration  
dornick hunter Process Filtration**  
Birtley, England  
+44 (0) 191 410 5121  
www.parker.com/processfiltration

## Asia Pacific

**Australia**  
Castle Hill, Australia  
+61 2 9634 7777  
www.parker.com/australia

**China**  
Shanghai, China  
+86 21 5031 2525  
www.parker.com/china

**India**  
Navi Mumbai, India  
+91 22 651 370 8185  
www.parker.com/india

**Japan**  
Tokyo, Japan  
+81 45 870 1522  
www.parker.com/japan

**Korea**  
Hwaseon-City  
+82 31 359 0852  
www.parker.com/korea

**Singapore**  
Jurong Town, Singapore  
+65 6887 6300  
www.parker.com/singapore

**Thailand**  
Bangkok, Thailand  
+66 2 186 7000  
www.parker.com/thailand

**Latin America  
Parker Comercio Ltda.  
Filtration Division**  
Sao Paulo, Brazil  
+55 12 4009 3500  
www.parker.com/br

**Pan American Division**  
Miami, FL  
305 470 8800  
www.parker.com/panam

**Africa**  
Aeroporto Kempton Park, South Africa  
+27 11 9610700  
www.parker.com/africa



Parker Hannifin Corporation  
**Filtration and Separation Division**  
242 Neck Road  
Haverhill, MA 01835  
T 978 858 0505, F 978 478 2501  
1 800 343 4048 (US & Canada)  
www.parker.com/balston

